

Memo

TO: Katherine DeStefano – ODOT District 8
FROM: Bryan Vasaris, PE
DATE: January 5, 2024 **PROJECT NO.:** 231473
SUBJECT: GRE-68 Constructability of Proposed Pedestrian Bridge

Fishbeck has reviewed the constructability of the proposed pedestrian bridge to be constructed connecting the Little Miami Scenic Trail (LMST) to the Shawnee Interpretive Center in Greene County, OH. This review focuses on constructing the bridge within the existing 50' wide right-of-way which runs parallel to the proposed structure between US 68 and LMST.

Assumptions

- All equipment access to occur from US 68* – Equipment access using the LMST is not practical, as existing access to LMST occurs only at its intersection with Brush Row Road. Additionally, LMST is narrow width pavement ($\pm 10'$) not designed for heavy equipment loading. Furthermore, continued use of Brush Row Road for construction access activities is also not practical. The 50' width available at US 68 is adequate for the passage of trucks and equipment simultaneously.
- Staging Area* – The proposed rear abutment, retaining wall and west access ramp will be constructed last. Leaving this construction to the end of the project allows the 3 parcels on the west side of US 68 to be used as staging area. Dimensions of this area are approximately 175' x 130'. Full or partial use of this area is adequate for material delivery and equipment storage or staging. A portion of this area is also directly across from the subject 50' right-of-way allowing for increased mobility into the east portion of the project site.
- Crane Equipment* – Fishbeck has assumed 2 crawler type cranes will be required to lift the truss spans into place. This is due to capacity required and available width between outermost pier tip and construction limit. Crawler cranes are typically narrower than wheeled cranes, in lift operation, not requiring as much outrigger support.
 - The 150' long truss span is $\pm 17'-4''$ wide and estimated to weigh approximately 125,000 pounds.
 - Narrowest point of access between pier tip and construction limit is $\pm 18'-6''$.
- Concrete Pump* – A small 33 meter concrete pump, placed on the south side of the structure, can be used to place the concrete deck. This size pump truck balances boom reach, maneuverability, and outrigger support. The approximate outrigger width is $\pm 20'-8''$.

Construction Sequence

It is assumed construction of the pedestrian bridge will occur from east to west, building Span 4 first. Substructure units and spans will be built individually allowing maximum access to the site throughout construction. Building substructure units to completion first, as traditionally done, will reduce access width approximately 50% increasing delivery and construction difficulty. Note ground improvements and crane mats

may be required to improve access and stability throughout the site. The east end of the bridge at the forward abutment is at a lower elevation as compared to US 68.

Span 4 (150' Prefabricated Truss)

1. Construct temporary access fill to allow equipment access across Oldtown Creek. Temporary access fill will need to consider the potential for higher crane loading.
2. Construct forward abutment and Pier 3.
3. Assemble truss at ground level adjacent to Pier 3.
4. Utilize 2 cranes to lift and place assembled truss onto bearings.
 - Note: Truss assembly location can occur in the open space between US 68 and Pier 3, this location would require more coordination between cranes to maneuver around Pier 3.
5. Place concrete deck.

Span 3 (Alternative 2A – 117'-6" Prefabricated Truss)

1. Construct Pier 2.
2. Assemble truss at ground level adjacent to final Span 3 location.
3. Utilize 2 cranes to lift and place assembled truss onto bearings.
 - Note: West side crane placement will likely be on or near abandoned septic tank. Also, care shall be taken to avoid garage on adjacent property during crane movement.
4. Place concrete deck.

Span 3 (Alternative 2B – 117'-6" Precast Concrete Beams)

1. Construct Pier 2.
2. Place beams individually starting with Beam 1, to the north, and working to the south with Beams 2 and 3. Lifting the beam from the center may allow the use of a single crane.
 - Note: Fishbeck has discussed delivery of concrete I beams to this site with a local precast concrete beam manufacturer. Delivery to this site was confirmed to be feasible.
3. Concrete deck placement will be completed after Span 2 is placed to allow proper continuity between beam spans to be achieved.

Span 2 (117'-6" Prefabricated Truss or Precast Concrete Beams)

1. Construct Pier 1.
2. Placement of assembled truss or precast beams will occur similar to Span 3. Temporary lane closure may be required to allow crane placement near Pier 1.
3. Place concrete deck.

Span 1 (95'-0" Prefabricated Truss)

1. Construct retaining wall and rear abutment. Construction of rear abutment will reduce the available staging area on the west side of US 68 as the rear abutment is expected to be built on new fill behind a retaining wall.
2. Assemble truss in remaining staging area adjacent to US 68.
 - Note: Span 1 is the shortest of the four spans at 95'-0". Depending on the truss manufacturer, it may be possible for the truss to be lifted directly from the trailer without the need for pre-assembly.
3. Temporarily close US 68 for truss placement.
4. Place truss on bearings.
5. Place concrete deck.

Construction of Span 1 prior to Span 2 is another viable solution. This would allow for the prefabricated truss to be assembled at ground level adjacent to Pier 1 and Pier 2. Span 2 truss or concrete beams could then be placed as previously described.

Constructing the proposed project in the described manner, will be slower and more costly than traditional construction sequences. Building the spans individually will require the contractor to maintain equipment and operator availability for a longer duration. However, Fishbeck believes the project can be constructed within existing right-of-way and additional temporary right-of-way is not required.

Attachments: Constructability Exhibit
Crane Dimensions and Operating Capacities
Concrete Pump Truck Dimensions

Attachment 1

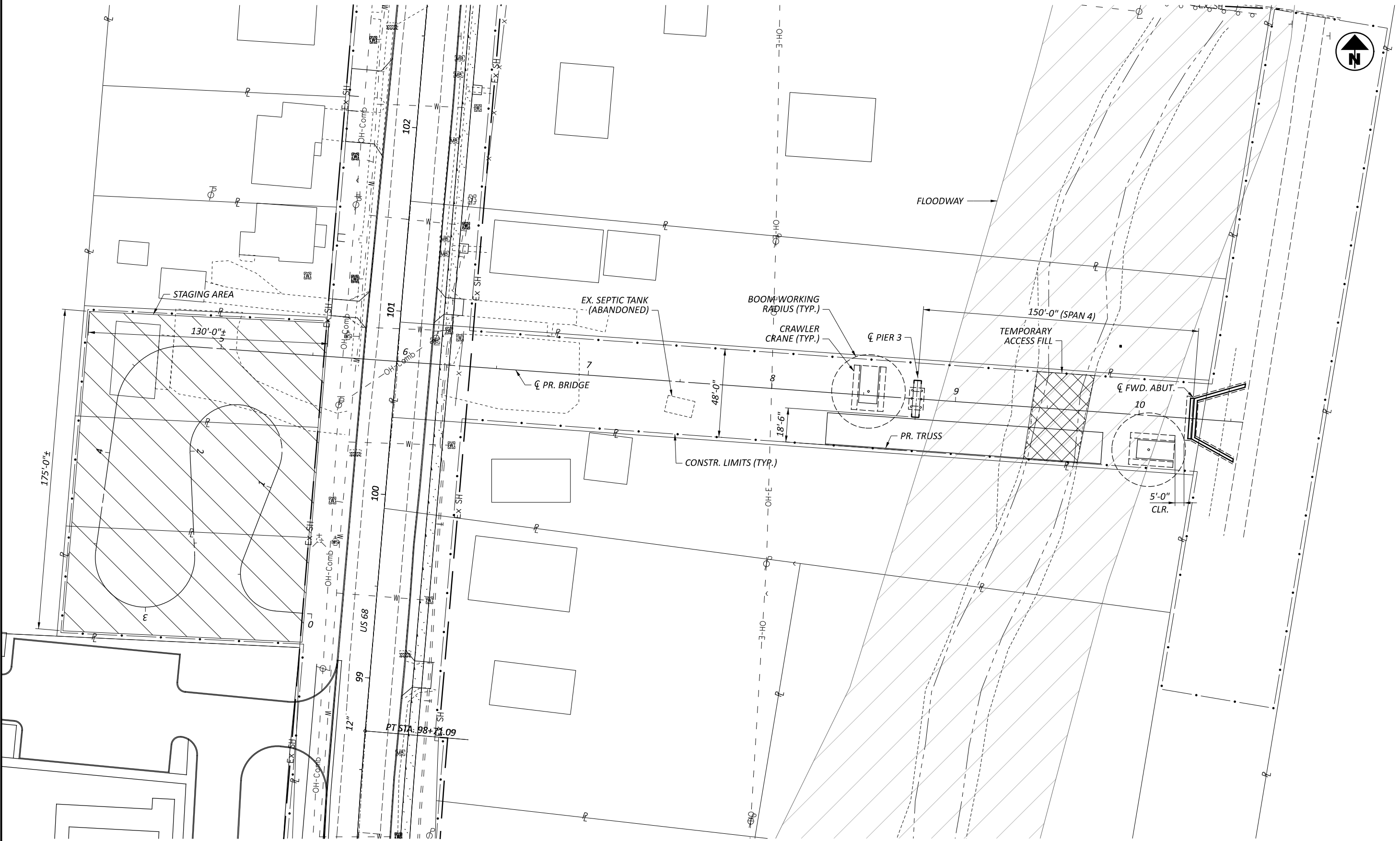

NOTES:

1. ALL EQUIPMENT ACCESS ASSUMED TO OCCUR FROM US 68.
2. ASSUMES TRUSS IS ASSEMBLED AT GROUND LEVEL AND LIFTED INTO PLACE.

SFN 2926107	
DESIGN AGENCY fishbeck	
DESIGNER BMV	CHECKER JPC
REVIEWER	
PROJECT ID 115388	
SUBSET	TOTAL
SHEET	TOTAL

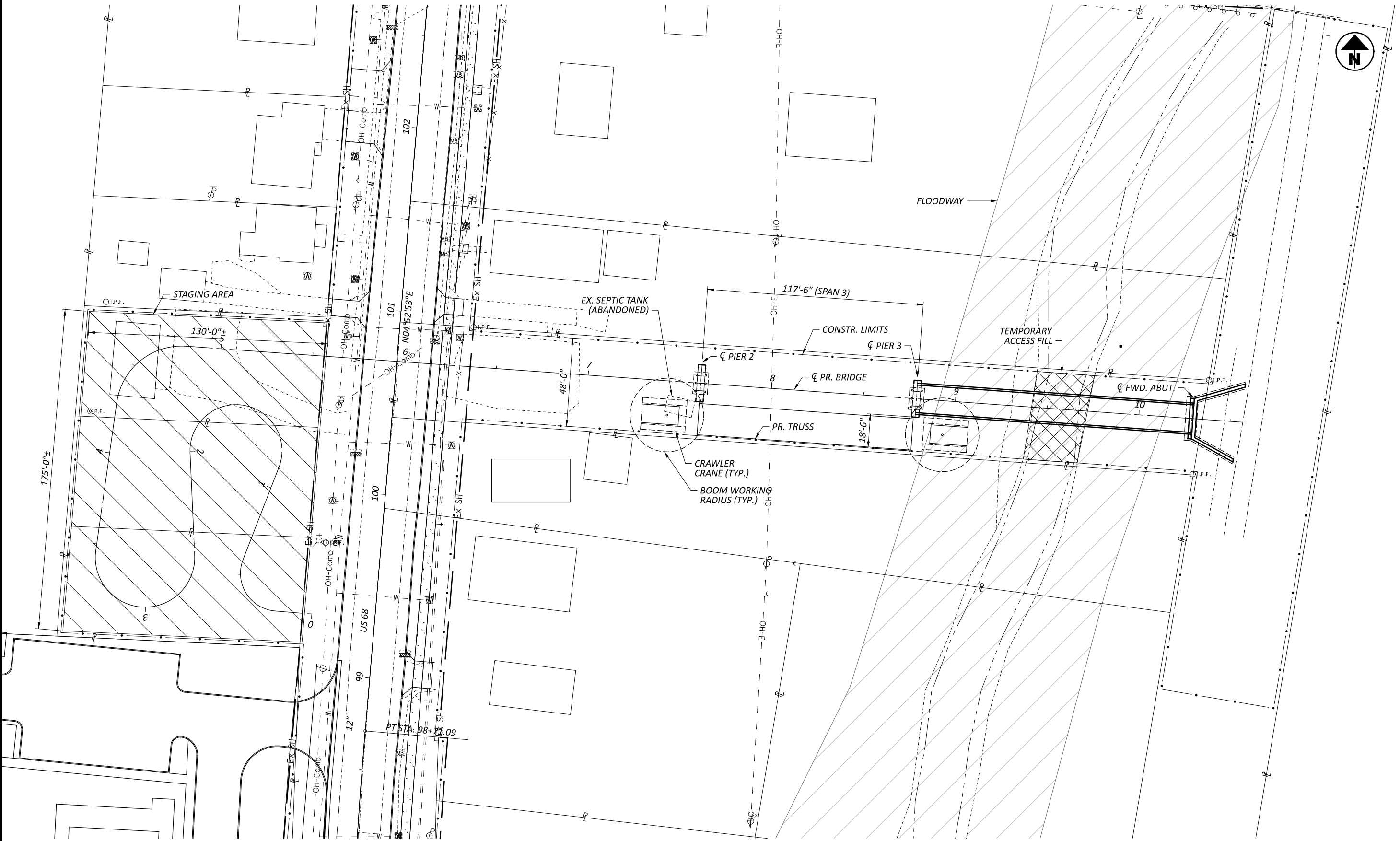

NOTES:

1. ALL EQUIPMENT ACCESS ASSUMED TO OCCUR FROM US 68.
2. ASSUMES TRUSS IS ASSEMBLED AT GROUND LEVEL AND LIFTED INTO PLACE.

SFN	2926107
DESIGN AGENCY	fishbeck
DESIGNER	CHECKER
BMV	JPC
REVIEWER	
PROJECT ID	115388
SUBSET	TOTAL
SHEET	TOTAL

Attachment 2

Dimensions

Transport dimensions and weights

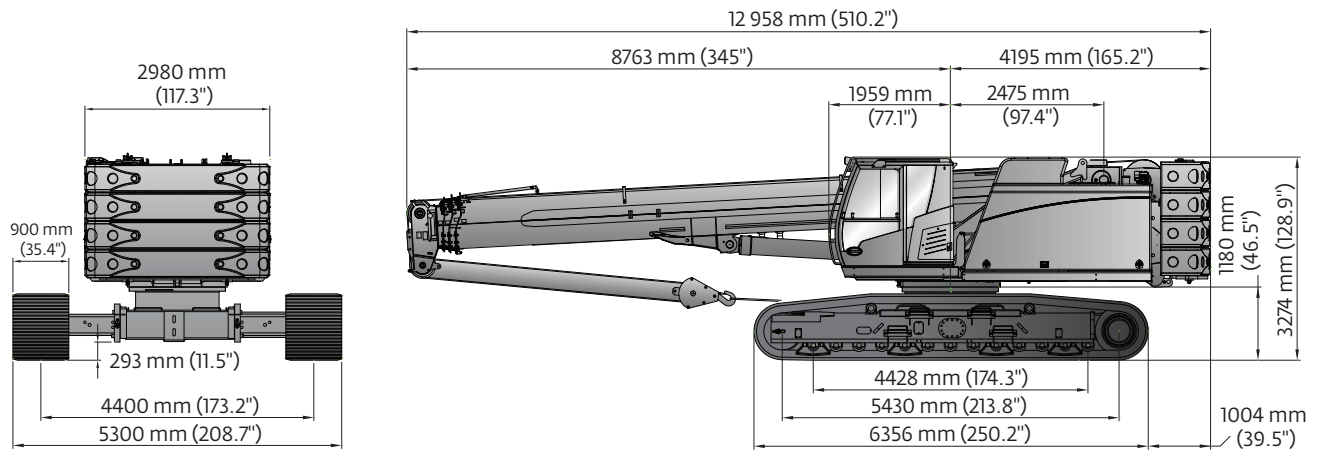

Operating weight: approximately 65 165 kg (143,665 lbs) with 8 m (26 ft 3 in) boom extension, 2 hoists, 900 mm (35.4 in) triple bar shoes, 35 t (38.5 USt) hookblock and 17.8 t (39,245 lbs) counterweight.

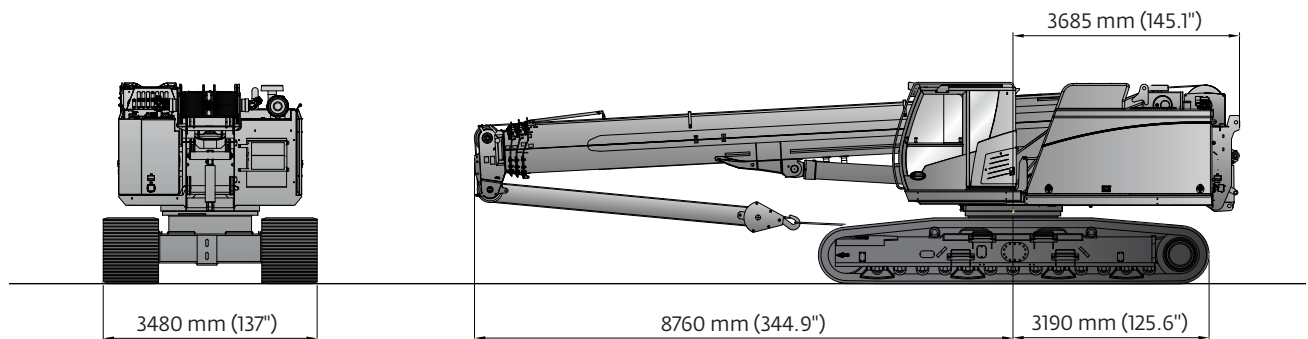

Transport weight: approximately 47 365 kg (104,420 lbs) with 8 m (26 ft 3 in) boom extension, 2 hoists, 900 mm (35.4 in) triple bar shoes, 35 t (38.5 USt) hookblock and no counterweight.

Working range

Main boom – imperial 75%

Main boom

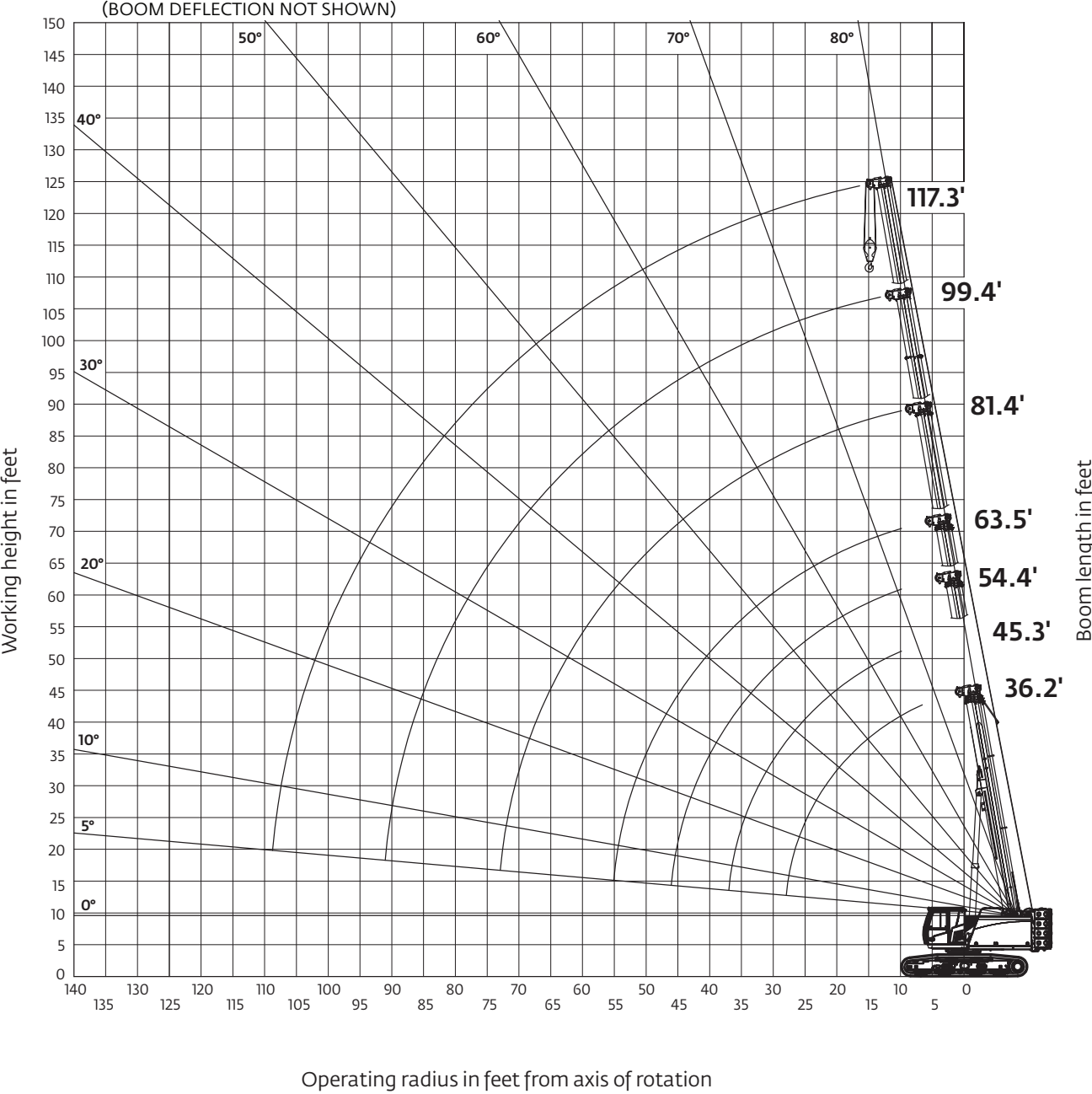

*THIS CHART IS ONLY A GUIDE AND SHOULD NOT BE USED TO OPERATE THE CRANE.
The individual crane's load chart, operating instructions and other instructional plates must be read and understood prior to operating the crane.*

Load chart

Main boom – imperial 75%



117.3 ft



39,245 lb



100%



360°



Pounds

Radius in feet	Main boom length in feet						
	36.2	45.3	54.4	63.5	81.4	99.4	117.3
7	150,000	—	—	—	—	—	—
10	147,100	133,800	96,400	82,900	49,600	—	—
15	109,500	106,800	77,100	66,800	49,600	45,200	—
20	81,000	80,100	63,600	54,800	48,300	40,300	31,900
25	61,200	60,000	54,200	46,600	41,100	35,200	30,200
30	—	44,900	44,200	40,100	35,700	30,700	27,500
35	—	35,300	34,900	34,300	31,300	27,000	24,700
40	—	—	28,200	28,000	27,700	23,900	22,200
45	—	—	—	23,300	24,200	21,400	19,600
50	—	—	—	19,600	20,700	19,300	17,600
55	—	—	—	—	17,700	17,500	15,700
60	—	—	—	—	15,300	15,800	14,100
65	—	—	—	—	13,300	13,900	12,900
70	—	—	—	—	—	12,200	11,900
75	—	—	—	—	—	10,700	11,000
80	—	—	—	—	—	9400	10,100
85	—	—	—	—	—	8200	8900
90	—	—	—	—	—	—	7900
95	—	—	—	—	—	—	6900
100	—	—	—	—	—	—	6000
105	—	—	—	—	—	—	5300
When 26.2' extension is in stowed position, the rated loads must be reduced as follows:							
Reduction of load (lb)	1056	842	700	593	461	378	327
Lifting capacities at 4° boom angle							
Boom Angle	Main boom length in feet						
	36.2	45.3	54.4	63.5	81.4	99.4	117.3
4°	51,100 (27.9)	32,200 (37.1)	23,400 (46.3)	15,900 (55.1)	9700 (73.2)	5500 (91.2)	700 (109.3)

NOTE: () reference radii in meters.

*THIS CHART IS ONLY A GUIDE AND SHOULD NOT BE USED TO OPERATE THE CRANE.
The individual crane's load chart, operating instructions and other instructional plates must be read and understood prior to operating the crane.*

Attachment 3

33M

JXZ 33-4.16



GENERAL

PIPE SIZE (ID)	125 mm (5")
BOOM CONTROL VALVE	Proportional (by HAWE)
RADIO REMOTE	Dual Wireless Transmitter System
VIBRATOR	Standard
WATER PUMP	Hydraulic Power 20 bar (290 psi)
WATER TANK	500 L (132 G)
WEAR PARTS	Carbide
POPULAR UPGRADES [†]	<ul style="list-style-type: none"> • LED Boom Light Kit • LED Outrigger Lights • Heated Water Tank • Heated Hydraulic Tank • Air-Cuff • Twin Wall Pipe

BOOM

NUMBER OF BOOMS	4 Sections
FOLDING TYPE	Z Fold
VERTICAL HEIGHT	32.5 m (106'8")
HORIZONTAL REACH	28.5 m (93'6")
UNFOLDING HEIGHT	7.6 m (24'11")
1ST SECTION	8.0 m (26'3")
2ND SECTION	6.85 m (22'6")
3RD SECTION	6.85 m (22'6")
4TH SECTION	6.8 m (22'4")
FRONT OUTRIGGER	X-Style
REAR OUTRIGGER	T-Style
FRONT SPREAD	6.3 m (20'8")
REAR SPREAD	3.9 m (12'9")

[†]More options available, ask your sales rep for details.

PUMP

OUTPUT:	Rod Side	164 m³/h (215 yd³/h)
	Piston Side	102 m³/h (133 yd³/h)
PRESSURE:	Rod Side	72 Bar (1044 psi)
	Piston Side	115[‡] bar (1668 psi)
CONCRETE CYLINDER DIAMETER	230 mm (9")	
CONCRETE CYLINDER TYPE	Hard Chromed	
STROKE LENGTH	2100 mm (83")	
S-TUBE SIZE	9" x 7"	
MAIN OIL PUMP	Rexroth hydromatic A11VLO260	
HYDRAULIC SYSTEM PRESSURE	350 bar (5076 psi)	
LUBE SYSTEM (HOPPER)	Automatic	
SWITCHING SYSTEM	Hydraulic	
HOPPER CAPACITY	Easy Clean 600 L (158 G)	
NUMBER OF STROKES/MIN	31	
OUTPUT CONTROL RANGE	10(13)-164m³/h (215yd³/h)	

[‡]Not to be used through boom pipe

Alliance Concrete Pumps Inc. reserves the right to make changes to all specifications

ALLIANCECONCRETEPUMPS.COM



USA OFFICE: 800 West Ridge Road, Linwood, PA 19061

Toll Free 1.888.584.7231 | Phone 610.584.7231 | Fax 610.584.7251

CANADA OFFICE: 26162 30A Avenue, Aldergrove, BC V4W 2W5

Toll Free 1.888.870.0908 | Phone 604.607.0908 | Fax 604.607.0903

33M WEIGHTS/DIMENSIONS



CHASSIS

MAKE/MODEL	FRONT AXLE	REAR AXLE	OVERALL LENGTH	TOTAL WEIGHT
SMALL CONVENTIONAL	15,600 lbs	38,900 lbs	37'/11.3m	54,500 lbs
LARGE CONVENTIONAL	17,500 lbs	39,250 lbs	37'8\"/>11.5m	56,750 lbs
CAB OVER	19,400 lbs	36,400 lbs	35'4\"/>10.76m	55,800 lbs

DIAGRAMS

OUTRIGGER EXTENSION

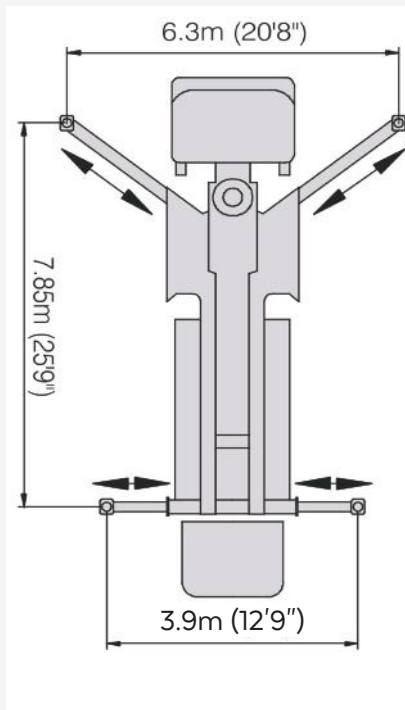

BOOM PUMP REACH

