

SHEET NUM.				PART.	ITEM	ITEM EXT	GRAND TOTAL	UNIT	DESCRIPTION	SEE SHEET NO.	
3	5	8	18								
				01/STR/BR					STRUCTURE OVER 20 FOOT SPAN (HAN-568-5.57)		
				LUMP	LUMP	202	11002	LS	STRUCTURE REMOVED, OVER 20 FOOT SPAN		
				80	80	202	22900	80	SY	APPROACH SLAB REMOVED	
				LUMP	LUMP	503	11100	LS	COFFERDAMS AND EXCAVATION BRACING		
				LUMP	LUMP	503	21301	LS	UNCLASSIFIED EXCAVATION, AS PER PLAN	16	
				39,888	39,888	509	10001	39,888	LB	EPOXY COATED REINFORCING STEEL, AS PER PLAN	16
				165	165	511	21522	165	CY	CLASS QC2 CONCRETE WITH QC/QA, SUPERSTRUCTURE	
				2	2	511	33500	2	EACH	SEMI-INTEGRAL DIAPHRAGM GUIDE	
				102	102	511	43510	102	CY	CLASS QC1 CONCRETE, ABUTMENT INCLUDING FOOTING	
				143	143	512	10100	143	SY	SEALING OF CONCRETE SURFACES (EPOXY-URETHANE)	
				98,394	98,394	513	10281	98,394	LB	STRUCTURAL STEEL MEMBERS, LEVEL 4, AS PER PLAN	16
				816	816	513	20000	816	EACH	WELDED STUD SHEAR CONNECTORS	
				91	91	516	13900	91	SF	2" PREFORMED EXPANSION JOINT FILLER	
				127	127	516	14021	127	FT	SEMI-INTEGRAL ABUTMENT EXPANSION JOINT SEAL, AS PER PLAN	17
				8	8	516	44101	8	EACH	ELASTOMERIC BEARING WITH INTERNAL LAMINATES AND LOAD PLATE (NEOPRENE), AS PER PLAN (12"x12"x2")	22
				222	222	517	70000	222	FT	RAILING (TWIN STEEL TUBE)	
				LUMP	LUMP	518	21230	LS	POROUS BACKFILL WITH GEOTEXTILE FABRIC		
				250	250	SPECIAL	51822300	250	FT	STEEL DRIP STRIP (DS-1-92)	
				132	132	518	40000	132	FT	6" PERFORATED CORRUGATED PLASTIC PIPE	
				80	80	518	40010	80	FT	6" NON-PERFORATED CORRUGATED PLASTIC PIPE, INCLUDING SPECIALS	
				107	107	524	94702	107	FT	DRILLED SHAFTS, 36" DIAMETER, ABOVE BEDROCK	
				36	36	524	94704	36	FT	DRILLED SHAFTS, 36" DIAMETER, INTO BEDROCK	
				213	213	526	30001	213	SY	REINFORCED CONCRETE APPROACH SLABS (T=17"), AS PER PLAN	17
				91	91	526	90010	91	FT	TYPE A INSTALLATION	
				224	224	601	32104	224	CY	ROCK CHANNEL PROTECTION, TYPE B WITH GEOTEXTILE FABRIC	
				38	38	846	00110	38	CF	POLYMER MODIFIED ASPHALT EXPANSION JOINT SYSTEM	
										MAINTENANCE OF TRAFFIC	
				20	20	253	02000	20	CY	PAVEMENT REPAIR	
				20	20	407	10000	20	GAL	TACK COAT	
				10	10	441	50000	10	CY	ASPHALT CONCRETE SURFACE COURSE, TYPE 1, (448), PG64-22	
				1	1	616	10000	1	MGAL	WATER	
				50	50	617	10100	50	CY	COMPACTED AGGREGATE	
										INCIDENTALS	
				LS	614	11000	LS			MAINTAINING TRAFFIC	
				5	619	16010	5	MNTH		FIELD OFFICE, TYPE B	
				LS	623	10000	LS			CONSTRUCTION LAYOUT STAKES AND SURVEYING	
				LS	624	10000	LS			MOBILIZATION	

I:\Projectdata\98588\Design\Roadway\Sheets\98588.GG002.dgn Sheet 02-MAR-2020 10:12AM mlimboug

**GENERAL SUMMARY**

**HAN - 568 - 5.57**

CALCULATED  
MAL  
CHECKED  
RDM

!!:\Projectdata\98588\Design\Structure\Sheets\98588EQ001.dgn Sheet 02-MAR-2020 10:12AM mirimbaug

ESTIMATED QUANTITIES										
ITEM	EXTENSION	01/STR/BR TOTAL	UNIT	DESCRIPTION	APPR. SLAB	ABUT.	SUPER.	GEN.	SHEET #	
202	11002	LUMP		STRUCTURE REMOVED, OVER 20 FOOT SPAN				LUMP		
202	22900	80	SQ YD	APPROACH SLAB REMOVED	80					
503	11100	LUMP		COFFERDAMS AND EXCAVATION BRACING				LUMP		
503	21301	LUMP		UNCLASSIFIED EXCAVATION, AS PER PLAN		LUMP			2/16	
509	10001	39888	POUND	EPOXY COATED REINFORCING STEEL, AS PER PLAN		13342	26546		2/16	
511	21522	165	CU YD	CLASS QC2 CONCRETE WITH QC/QA, SUPERSTRUCTURE		58	107			
511	33500	2	EACH	SEMI-INTEGRAL DIAPHRAGM GUIDE		2				
511	43510	102	CU YD	CLASS QC1 CONCRETE, ABUTMENT INCLUDING FOOTING		102				
512	10100	143	SQ YD	SEALING OF CONCRETE SURFACES (EPOXY-URETHANE)		98	45			
513	10281	98394	POUND	STRUCTURAL STEEL MEMBERS, LEVEL 4, AS PER PLAN			98394		2/16	
513	20000	816	EACH	WELDED STUD SHEAR CONNECTORS			816			
516	13900	91	SQ FT	2" PREFORMED EXPANSION JOINT FILLER		91				
516	14021	127	FT	SEMI-INTEGRAL ABUTMENT EXPANSION JOINT SEAL, AS PER PLAN		127			3/16	
516	44101	8	EACH	ELASTOMERIC BEARING WITH INTERNAL LAMINATES AND LOAD PLATE (NEOPRENE) (12" x 12" x 2"), AS PER PLAN		8			8/16	
517	70000	222	FT	RAILING (TWIN STEEL TUBE)			222			
518	21230	LUMP		POROUS BACKFILL WITH FILTER FABRIC		LUMP				
518	22300	250	FT	SPECIAL - STEEL DRIP STRIP			250			
518	40000	132	FT	6" PERFORATED CORRUGATED PLASTIC PIPE		132				
518	40010	80	FT	6" NON-PERFORATED CORRUGATED PLASTIC PIPE, INCLUDING SPECIALS		80				
524	94702	107	FT	DRILLED SHAFTS, 36" DIAMETER, ABOVE BEDROCK		107				
524	94704	36	FT	DRILLED SHAFTS, 36" DIAMETER, INTO BEDROCK		36				
526	30001	213	SQ YD	REINFORCED CONCRETE APPROACH SLABS (T=17"), AS PER PLAN	213				3/16	
526	90010	91	FT	TYPE A INSTALLATION	91					
601	32104	224	CY	ROCK CHANNEL PROTECTION, TYPE B WITH GEOTEXTILE FABRIC		224				
846	00110	38	CU FT	POLYMER MODIFIED ASPHALT EXPANSION JOINT SYSTEM	38					

DESIGN AGENCY  
ODOT DISTRICT ONE,  
CAPITAL PROGRAMS

REVIEWED DATE  
JRC 12/16/2019  
STRUCTURE FILE NUMBER  
3204929

DRAWN MAL  
REVISOR MAL

DESIGNED MAL  
CHECKED RTH

ESTIMATED QUANTITIES  
HAN-568-5.57  
OVER OUTLET DITCH

HAN-568-5.57  
PID No. 98588

4 / 16

18  
35

I:\Projectdata\98588\Design\Structure\Sheet\98588S1001.dgn Sheet 02-MAR-2020 10:24AM mlmbaug

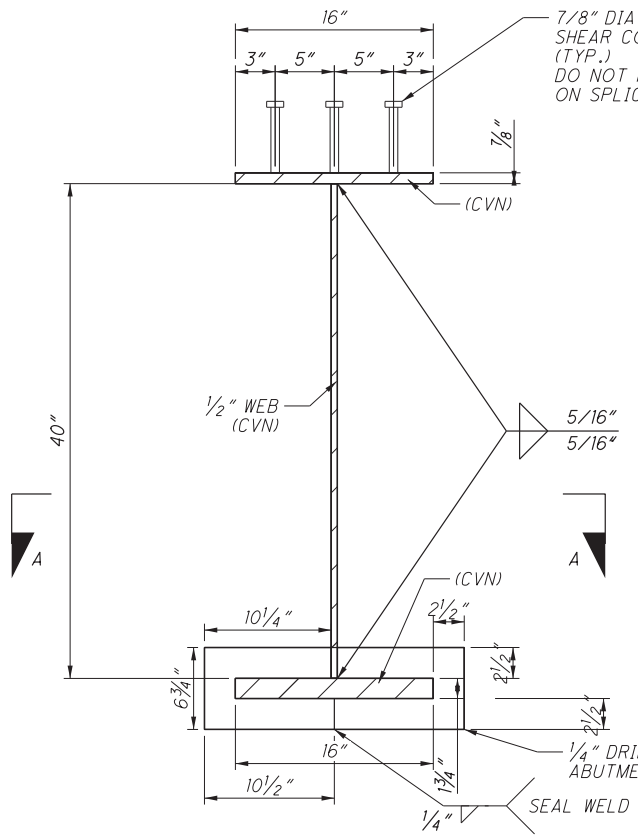

GIRDER AND SHEAR CONNECTOR DETAIL

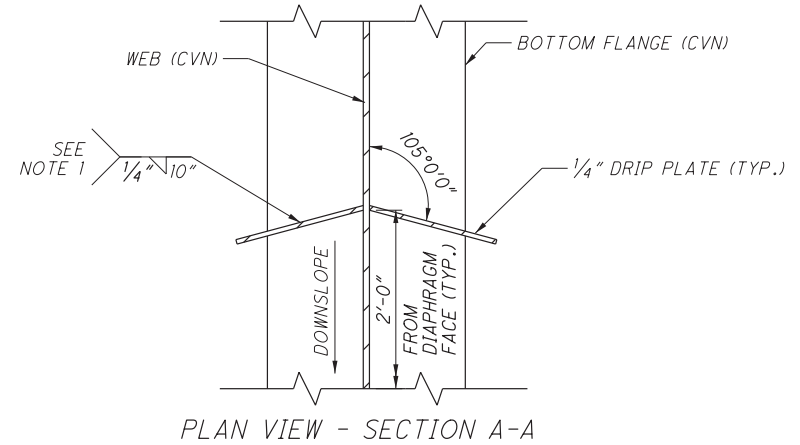

PLAN VIEW - SECTION A-A

NOTE:  
1. ONLY WELD THE UPSIDE OF THE DRIP PLATE TO THE FLANGE AND WEB

LIMITS OF ITEM 512,  
SEALING OF CONCRETE  
SURFACES (EPOXY-URETHANE)  
TYP. BOTH SIDES

3 ROWS OF 4 -S402 SPAC. @ 12" MAX  
= 24 TOTAL  
BOTTOM OF OVERHANG (TYP.)

L3 1/2" X 3 1/2" X 3/8" CROSSFRAME ANGLES (TYP.)  
STIFFENERS AND CROSSFRAMES ARE TYPE 4 PER  
STD. DWG. GSD-1-96

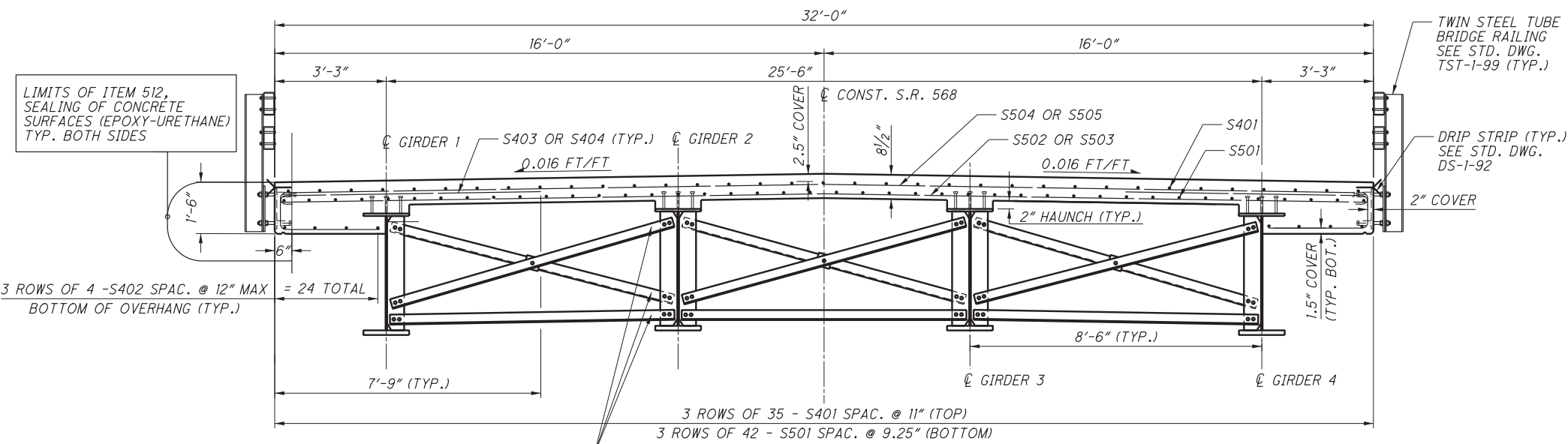

DECK TRANSVERSE SECTION

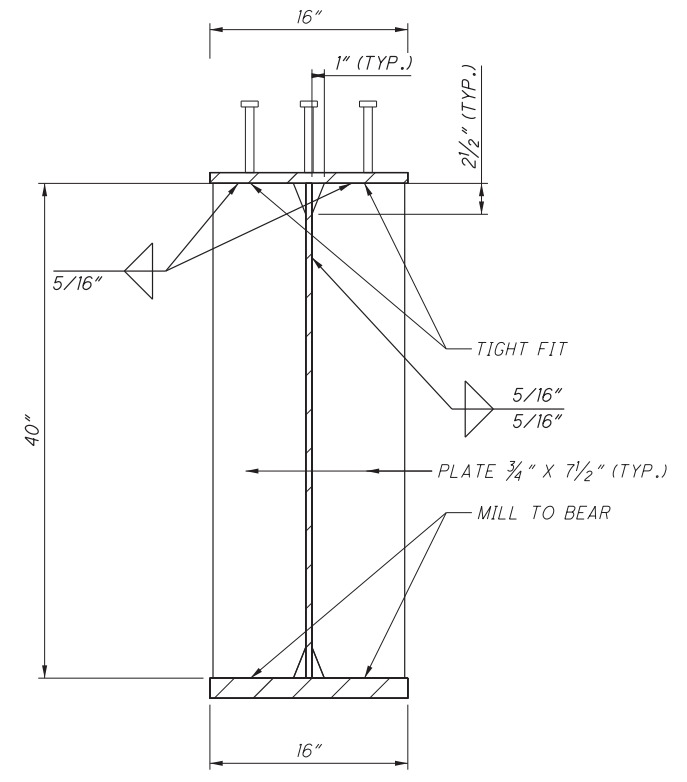

BEARING STIFFENERS  
FWD. & REAR ABUT.  
AT BEARING OF  
ALL GIRDERS

DESIGN AGENCY	ODOT, DISTRICT ONE,
CAPITAL PROGRAMS	
DESIGNED	MAL
CHECKED	RTH
DRAWN	RBM
REVISIED	MAL
REVIEWED	JRC
DATE	12/16/2019
STRUCTURE FILE NUMBER	3204929
TYPICAL SECTION	
HAN-568-5.57	
PID No. 98588	
OVER OUTLET DITCH	
9 / 16	
23	
35	