

HAR - SR 37/SR 53-00.00/01.34
 200597 PID - 107683
 Dist 1 12/17/2020

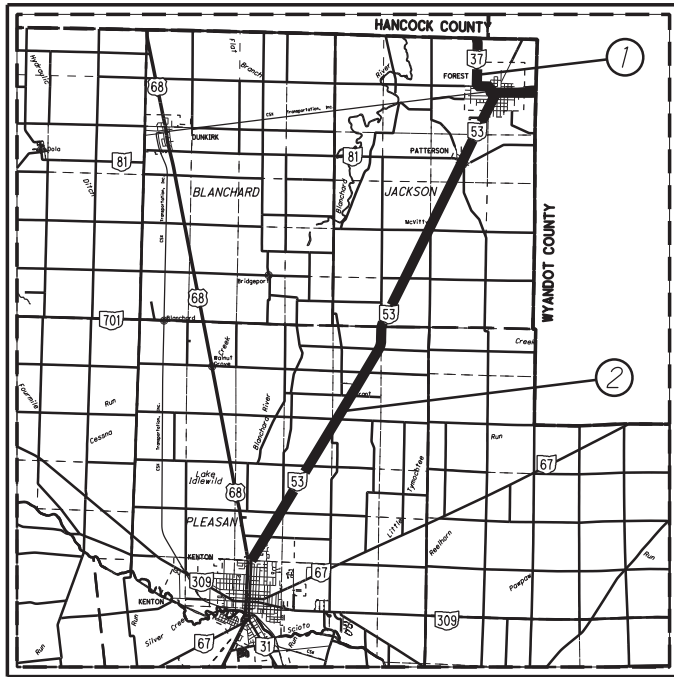

LOCATION MAP

- ① HAR-37-0.00
- ② HAR-53-1.34

STATE OF OHIO
 DEPARTMENT OF TRANSPORTATION
HAR-37 / 53-
0.00 / 1.34
Villages of Forest and Patterson
City of Kenton
Pleasant and
Jackson Townships
Hardin County

INDEX OF SHEETS:

TITLE SHEET	1
GENERAL NOTES	2 - 3
ASPHALT CONCRETE	4 - 5
PAVEMENT MARKING SUB-SUMMARY	6
INTERSECTION SUB-SUMMARY	7
CURB RAMP SUB-SUMMARY	8
CURB RAMP DETAILS	9 - 15
GENERAL SUMMARY	16

PROJECT DESCRIPTION

REHABILITATION OF 2.36 MILES OF ROADWAY ON SR 37, AND 11.05 MILES OF ROADWAY ON SR 53 IN HARDIN COUNTY. REHABILITATE BY PAVEMENT PLANING, RESURFACING AND PLACING PAVEMENT MARKINGS. CONSTRUCTION OF CURB RAMPS WILL OCCUR IN THE VILLAGE OF FOREST AND THE VILLAGE OF PATTERSON.

EARTH DISTURBED AREAS

PROJECT EARTH DISTURBED AREA: N/A *
 ESTIMATED CONTRACTOR EARTH DISTURBED AREA: N/A *
 NOTICE OF INTENT EARTH DISTURBED AREA: N/A *
 * - (MAINTENANCE PROJECT)

2019 SPECIFICATIONS

THE STANDARD SPECIFICATIONS OF THE STATE OF OHIO, DEPARTMENT OF TRANSPORTATION, INCLUDING CHANGES LISTED IN THE PROPOSAL SHALL GOVERN THIS IMPROVEMENT.

I HEREBY APPROVE THESE PLANS AND DECLARE THAT THE MAKING OF THESE IMPROVEMENTS WILL NOT REQUIRE THE CLOSING OF THE HIGHWAY AND PROVISIONS FOR THE MAINTENANCE AND SAFETY OF TRAFFIC WILL BE AS INDICATED IN THE PROPOSAL.

PORTION TO BE IMPROVED	-----	=====
INTERSTATE HIGHWAY	-----	=====
FEDERAL ROUTES	-----	=====
STATE ROUTES	-----	=====
COUNTY & TOWNSHIP ROADS	-----	=====
OTHER ROADS	-----	=====

DESIGN DESIGNATION	SR 37	SR 53
CURRENT ADT (2018)	3379	8357
DESIGN YEAR ADT (2041)	3500	13500
DESIGN HOURLY VOLUME (2041)	400	1400
DIRECTIONAL DISTRIBUTION	0.66	0.55
TRUCKS (24 HOUR B&C)	0.09	0.02
DESIGN SPEED	Varies	Varies
LEGAL SPEED	Varies	Varies
DESIGN FUNCTIONAL CLASSIFICATION:		
MAJOR COLLECTOR		



PLAN PREPARED BY:
 District One
 Ohio Department of Transportation
 Lima, Ohio

ENGINEERS SEAL

SIGNED: *Eric J. Scheckelhoff*
 DATE: 9/16/2020

STANDARD CONSTRUCTION DRAWINGS				SUPPLEMENTAL SPECIFICATIONS	
BP-3.1	1/17/20	TC-64.10	1/17/20	800	10/16/20
BP-5.1	1/18/19	TC-65.10	1/17/14	832	10/19/18
BP-7.1	7/20/18	TC-65.11	7/21/17	875	1/18/19
		TC-71.10	1/19/18	897	1/16/15
MT-97.10	4/19/19	DM-4.3	1/15/16		
MT-97.12	1/20/17	DM-4.4	1/15/16		
MT-99.20	4/19/19				
MT-101.90	7/21/17	CB-4.2	1/18/13		
MT-105.10	1/17/20				
MT-110.10	7/19/13				
TC-41.20	10/18/13				
TC-42.20	10/18/13				
TC-52.10	10/18/13				
TC-52.20	7/20/18				

APPROVED *Christopher A. Hughes*
 DATE 09/16/2020 DISTRICT DEPUTY DIRECTOR Digitally signed by Tom Pannett
 Date: 2020.11.10
 16:29:31-05'00'
 DATE _____ DIRECTOR, DEPARTMENT OF TRANSPORTATION

Contract Proposal available @
 www.contracts.dot.state.oh.us

I:\Project\data\107683\Design\Roadway\Sheets\107683_001.dgn Sheet 15-SEP-2020 2:19PM gir-win

FEDERAL PROJECT NO. E191(151)
 CONSTRUCTION PROJECT NO. 107683
 RAILROAD INVOLVEMENT CF&E RR
 HAR-37 / 53-0.00 / 1.34
 1/16

TRAFFIC:

TRAFFIC SHALL BE MAINTAINED AT ALL TIMES. THE LENGTH OF RESTRICTED TRAFFIC ZONES SHALL BE KEPT TO A MINIMUM CONSISTENT WITH REQUIREMENTS FOR PROTECTION OF COMPLETED COURSES.

RAILROAD CROSSINGS & BRIDGE TREATMENT:

THE NEW SURFACE COURSE SHALL BE FEATHERED OR BUTT JOINTED TO MEET THE PROFILE AS SPECIFIED BY THE ENGINEER. CONCRETE APPROACH SLABS AND BRIDGE DECKS SHALL NOT BE PAVED, UNLESS OTHERWISE NOTED IN THE PLANS (SEE SHEETS 5 THRU 8). THE CONTRACTOR SHALL TAKE ALL PRECAUTIONS TO PREVENT ANY ASPHALT CONCRETE MATERIAL FROM FALLING OFF THE EDGE OF A BRIDGE DECK OR EDGE OF A CULVERT DURING ANY CONSTRUCTION OPERATIONS. THE CONTRACTOR SHALL IMMEDIATELY REMOVE ANY MATERIAL THAT FALLS INTO THE ROADSIDE DITCHES OR STREAMS THROUGH NON-MECHANICAL MEANS. NO EQUIPMENT SHALL BE PERMITTED IN THE ROADSIDE DITCHES OR STREAMS.

ALIGNMENT AND PROFILE:

THE WORK PROPOSED BY THIS PROJECT IS FOR THE RESURFACING OF THE EXISTING PAVEMENT. PLACE THE PROPOSED PAVEMENT TO FOLLOW THE ALIGNMENT AND PROFILE OF THE EXISTING PAVEMENT.

EXTRA AREAS:

EXTRA AREAS SHALL INCLUDE DRIVEWAYS, MAILBOX PULL-OFFS AND OTHER SIMILAR AREAS AS DETERMINED BY THE ENGINEER. DRIVEWAYS SHALL BE FEATHERED IN APPROXIMATELY 6 FEET USING ASPHALT CONCRETE. SOME DRIVES MAY REQUIRE MORE THAN 6 FEET TO ALLOW FOR ADEQUATE TRANSITION TO THE MAINLINE PAVEMENT. THESE TRANSITIONS WILL BE AS DIRECTED BY THE ENGINEER. THE ASPHALT CONCRETE QUANTITIES FOR DRIVES AND MAILBOXES ARE INCLUDED IN THE EXTRA AREA QUANTITIES IN THE PAVEMENT DATA TABLE.

ASPHALT CONCRETE PLACEMENT ON SHOULDERS AND GUTTERS:

THE ASPHALT CONCRETE ON THE SHOULDERS AND CONCRETE GUTTERS SHALL BE PLACED AT THE SAME TIME THAT THE ASPHALT CONCRETE IS PLACED ON THE ADJACENT LANES OF PAVEMENT. THE SHOULDER MATERIAL SHALL BE PLACED AT THE SAME CROSS SLOPE AS THE EXISTING SHOULDER OR CONCRETE GUTTER GRADES. NEW CONCRETE CURB AND GUTTER AT LOCATIONS OF CURB RAMPS SHALL BE COMPLETED PRIOR TO PLACEMENT OF ASPHALT CONCRETE.

MAINTAINING TRAFFIC AT PLANED AREAS:

THE CONTRACTOR SHALL ARRANGE HIS OPERATIONS SO THAT TRAFFIC IS RETURNED TO AN AREA WHEN THE PLANING IS COMPLETE. THE PLANED AREA SHALL BE CLEANED TO THE SATISFACTION OF THE ENGINEER PRIOR TO PLACING TEMPORARY MARKINGS. ALL REQUIRED WORK ZONE PAVEMENT MARKINGS SHALL BE PLACED PRIOR TO OPENING THE AREA TO TRAFFIC. NO PLANED SURFACE SHALL REMAIN OPEN TO TRAFFIC MORE THAN (7) DAYS BEFORE BEING COVERED WITH AN ASPHALT COURSE. IF THIS IS NOT DONE, LIQUIDATED DAMAGES WILL BE LEVIED AS PER SECTION 108.07 OF THE ODOT CONSTRUCTION AND MATERIALS SPECIFICATIONS.

ITEM 617 COMPACTED AGGREGATE, AS PER PLAN:

THIS ITEM SHALL MEET ALL REQUIREMENTS FOR ITEM 617 COMPACTED AGGREGATE WITH THE FOLLOWING EXCEPTION:

- 1) NO RECYCLED ASPHALT CONCRETE PAVEMENT SHALL BE USED IN THIS ITEM

ALL COSTS ASSOCIATED WITH THE EQUIPMENT, LABOR AND MATERIALS NECESSARY FOR SUPPLYING AND PLACING THIS ITEM SHALL BE INCLUDED IN THE PRICE BID PER CUBIC YARD FOR ITEM 617 COMPACTED AGGREGATE, AS PER PLAN.

WEARING COURSE REMOVED AT INTERSECTIONS

TYPICAL WEARING COURSE REMOVED AT INTERSECTIONS AS DETAILED BELOW.

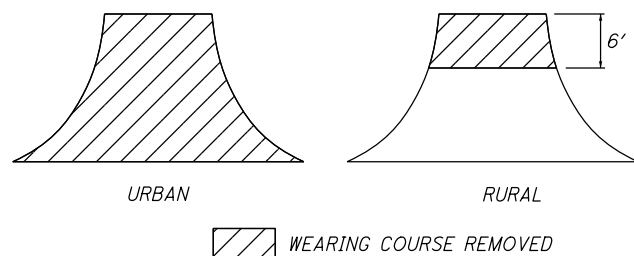

ITEM 253 - PAVEMENT REPAIR:

THIS ITEM OF WORK SHALL CONSIST OF THE REMOVAL OF THE EXISTING PAVEMENT OR PAVED BERM WHICH MAY BE ASPHALT, BRICK, CONCRETE, OR A COMBINATION OF EACH, IN AREAS OF EXISTING PAVEMENT FAILURE.

THE ENGINEER SHALL DESIGNATE THE LOCATIONS AND LIMITS OF THE AREAS TO BE PREPARED. THE REPAIR AREAS SHALL BE ROUGHLY RECTANGULAR IN SHAPE AND CUT OR SAWED TO A NEAT LINE. THE PAVEMENT SHALL BE REMOVED WITHIN THE DESIGNATED AREAS BY METHODS WHICH WILL NOT DAMAGE THE ADJACENT PAVEMENT. THE DEPTH OF REMOVAL, AS DIRECTED BY THE ENGINEER, SHALL BE SUFFICIENT TO REMOVE ALL DETERIORATED PAVEMENT. THE MATERIALS SO REMOVED SHALL BE DISPOSED OF IN ACCORDANCE WITH 203.01.

THE VERTICAL FACES OF THE REPAIR AREA SHALL BE TACKED PRIOR TO PLACING THE 301 FOR ITEM 253 PAVEMENT REPAIR. THIS MATERIAL SHALL BE PLACED AND COMPACTED TO FINISH FLUSH WITH THE ADJACENT EXISTING PAVEMENT SURFACE PRIOR TO PLACING THE PROPOSED ASPHALT CONCRETE OVERLAY. ALL COMPACTION SHALL BE ACHIEVED BY MECHANICAL METHODS TO THE SATISFACTION OF THE ENGINEER.

PAYMENT SHALL INCLUDE ALL LABOR, EQUIPMENT AND MATERIALS NECESSARY TO COMPLETE THE PAVEMENT REPAIR. AN ESTIMATED QUANTITY IS PROVIDED IN THE SUMMARY TO BE USED AS DIRECTED BY THE ENGINEER. PAYMENT WILL BE MADE AT THE UNIT PRICE BID PER CUBIC YARD OF ITEM 253 PAVEMENT REPAIR.

253 PAVEMENT REPAIR 403 CUBIC YARD

THE ABOVE ESTIMATED QUANTITY HAS BEEN CARRIED TO THE GENERAL SUMMARY FOR USE AT LOCATIONS IDENTIFIED BY THE ENGINEER. IT IS ESTIMATED THE REPAIRS WILL BE APPROXIMATELY 6 INCHES DEEP AND BE MOSTLY LONGITUDINAL REPAIRS. THE ESTIMATED WIDTH OF THESE REPAIRS ARE APPROXIMATELY 4 FEET. THERE ARE SEVERAL LOCATIONS WHERE THE ESTIMATED LENGTHS OF REPAIRS WILL BE BETWEEN APPROXIMATELY 50 FEET TO 150 FEET, AND THERE ARE A FEW LOCATIONS WHERE THE LENGTH OF REPAIRS ARE ESTIMATED TO BE APPROXIMATELY 200 FEET.

WORK ZONE MARKINGS AND SIGNS

ERECT A GROOVED PAVEMENT SIGN 250 FEET IN ADVANCE OF ANY SECTION OF ROADWAY WHERE TRAFFIC MUST TRAVEL ON A PLANED SURFACE. ENSURE THESE SIGNS ARE IN PLACE BEFORE OPENING THE ROADWAY TO TRAFFIC. ERECT THESE SIGNS AT INTERSECTIONS OF THROUGH ROUTES TO WARN TRAFFIC OF THIS SURFACE CONDITION. PAYMENT FOR THESE SIGNS TO BE INCLUDED IN ITEM 614 MAINTAINING TRAFFIC.

ERECT A NO EDGE LINES SIGN IN ADVANCE OF ANY SECTION OF ROADWAY WHERE TRAFFIC MUST TRAVEL ON A DO NOT PASS SIGN AT THE BEGINNING AND A PASS WITH CARE SIGN AT THE END OF EACH NO PASSING ZONE LACKING STANDARD CENTER LINE MARKINGS. ENSURE THESE SIGNS ARE IN PLACE BEFORE OPENING THE ROADWAY TO TRAFFIC. PAYMENT FOR THESE SIGNS TO BE INCLUDED IN ITEM 614 WORK ZONE MARKING SIGN.

THE FOLLOWING ESTIMATED QUANTITIES HAVE BEEN CARRIED TO THE GENERAL SUMMARY FOR USE AT LOCATIONS IDENTIFIED BY THE ENGINEER FOR WORK ZONE PAVEMENT MARKINGS AND SIGNS PER THE REQUIREMENTS OF CMS 614.04, 614.055 AND 614.11.

ITEM 614, WORK ZONE MARKING SIGN	82 EACH
ITEM 614, WORK ZONE CENTER LINE, CLASS I	13.42 MILES
ITEM 614, WORK ZONE CENTER LINE, CLASS II	26.84 MILES

446 DENSITY ACCEPTANCE WITH FLAGGER CLOSING OF A 2-LANE HIGHWAY FOR PAVING OPERATIONS

THIS PLAN NOTE APPLIES ONLY TO A FLAGGER CLOSURE OF ONE LANE OF A 2-LANE HIGHWAY DURING PAVING OPERATIONS WHEN USING STANDARD CONSTRUCTION DRAWING MT-97.11 OR MT-97.12, AND ALLOWS A PAVING OPERATION TO PROCEED CONCURRENTLY WITH THE MARKING AND CUTTING OF CORES REQUIRED FOR 446 DENSITY ACCEPTANCE.

IN ALL CASES THE CONTRACTOR SHOULD LENGTHEN THEIR LANE CLOSURES TO THE MAXIMUM PERMISSIBLE LENGTH DETAILED IN THE ABOVE REFERENCED STANDARD CONSTRUCTION DRAWINGS TO ALLOW THE ENGINEER ADEQUATE TIME TO MARK THE REQUIRED CORE LOCATIONS AND FOR CORE CUTTING OPERATIONS.

THE CONTRACTOR WILL PROVIDE TO THE ENGINEER THE PLANNED QUANTITY THAT WILL BE PLACED FOR THE DAY'S PRODUCTION. EACH DAY'S PRODUCTION WILL BE CONSIDERED ONE LOT AND INCLUDES SHOULDERS. TEN CORES WILL BE OBTAINED BY THE CONTRACTOR FOR EACH LOT AT RANDOM LOCATIONS DETERMINED BY THE ENGINEER. THE ENGINEER WILL DIVIDE A LOT INTO FIVE EQUAL SUBPLOTS AND CALCULATE TWO RANDOM CORE LOCATIONS IN EACH SUBPLOT AS DESCRIBED IN C&MS 446.05.

THE ENGINEER WILL MARK THE CORE LOCATIONS AFTER THE PAVING OPERATION (INCLUDING THE FINISH ROLLER) HAS COMPLETELY PASSED THE RANDOMLY SELECTED CORE LOCATION. THE CORE DRILL OPERATION CAN BEGIN CUTTING CORES WHEN THE NEWLY PLACED PAVEMENT SURFACE TEMPERATURE IS LESS THAN 140 DEGREES F. IT IS THE CONTRACTOR'S RESPONSIBILITY TO MAINTAIN THE LANE CLOSURE DURING ALL PAVING, MARKING, AND CORING OPERATIONS PER THE REQUIREMENTS OF THE STANDARD CONSTRUCTION DRAWING USED FOR THE PAVING OPERATION.

ITEM 614, MAINTAINING TRAFFIC

A MINIMUM OF 1 LANE OF TRAFFIC IN EACH DIRECTION SHALL BE MAINTAINED AT ALL TIMES BY USE OF THE EXISTING PAVEMENT, THE COMPLETED PAVEMENT, ITEM 502 STRUCTURE FOR MAINTAINING TRAFFIC, ITEM 615 PAVEMENT FOR MAINTAINING TRAFFIC, ITEM 615 ROADS FOR MAINTAINING TRAFFIC, AND TEMPORARY SURFACES USING ITEMS 410 AND 614.

ALL WORK AND TRAFFIC CONTROL DEVICES SHALL BE IN ACCORDANCE WITH C&MS 614 AND OTHER APPLICABLE PORTIONS OF THE SPECIFICATIONS, AS WELL AS THE OHIO MANUAL OF UNIFORM TRAFFIC CONTROL DEVICES. PAYMENT FOR ALL LABOR, EQUIPMENT AND MATERIALS SHALL BE INCLUDED IN THE LUMP SUM CONTRACT PRICE FOR ITEM 614, MAINTAINING TRAFFIC, UNLESS SEPARATELY ITEMIZED IN THE PLAN.

SINGLE - MAILBOX TURNOUT & BRIDGE APPROACHES

IF THERE IS A DISTANCE OF 100 FEET OR LESS BETWEEN MAILBOXES: APPROACHES SHALL BE PAVED THRU TO LAST MAILBOX.

IF THERE IS A DISTANCE OF 50 FEET OR LESS BETWEEN DRIVEWAY AND MAILBOX, APPROACHES SHALL BE PAVED THRU TO THE MAILBOX. THE CONTRACTOR SHALL BE RESPONSIBLE FOR EXCAVATION OF MATERIALS FROM ALL STONE DRIVEWAYS AND MAILBOX APPROACHES TO A DEPTH OF 2 INCHES BELOW EXISTING PAVEMENT. EXCAVATED MATERIAL SHALL BE DISPOSED OF BY THE CONTRACTOR AT HIS OWN RESPONSIBILITY OUTSIDE THE LIMITS OF THE HIGHWAY RIGHT OF WAY.

IF NEITHER OF THE ABOVE CONDITIONS APPLY AND PER THE DIRECTION OF THE PROJECT ENGINEER, A MAILBOX TURNOUT SHALL BE PROVIDED AS PER THE ADJACENT DETAIL.

FOR MAILBOX TURNOUTS, WHEN UNSTABLE MATERIAL IS ENCOUNTERED, EXCAVATION OF THIS MATERIAL SHALL BE TO A DEPTH OF 6 INCHES BELOW EXISTING PAVEMENT ELEVATION. AN ESTIMATED QUANTITY OF 304 AGGREGATE BASE HAS BEEN SET UP FOR BACK FILL OF THESE AREAS. EXCAVATED MATERIAL SHALL BE DISPOSED OF BY THE CONTRACTOR AT HIS OWN RESPONSIBILITY OUTSIDE THE LIMITS OF THE HIGHWAY RIGHT OF WAY.

AT BRIDGES WITH NO EXISTING BRIDGE APPROACHES AND PER THE DIRECTION OF THE PROJECT ENGINEER, BRIDGE APPROACHES SHALL BE PROVIDED PER THE ADJACENT DETAIL. THE AREA SHOWING THE LOCATION OF THE BRIDGE WILL HAVE VARIABLE LENGTH AND NO WORK IS NEEDED WITHIN THIS AREA UNLESS NOTED OTHERWISE IN THE PLANS.

FOR BRIDGE APPROACHES, THE BRIDGE APPROACHES SHALL BE EXCAVATED TO A DEPTH OF 9 INCHES BELOW EXISTING ADJACENT PAVEMENT ELEVATIONS. AN ESTIMATED QUANTITY OF 304 AGGREGATE BASE HAS BEEN SET UP FOR BACK FILL TO A DEPTH OF 6 INCHES FOR THESE AREAS, AND ESTIMATED QUANTITIES OF ASPHALT SURFACE COURSE AND TACK COAT HAVE BEEN SET UP FOR PLACEMENT OF TWO ASPHALT CONCRETE SURFACE COURSES, EACH COURSE BEING 1 1/2 INCHES THICK, FOR THESE AREAS. EXCAVATED MATERIAL SHALL BE DISPOSED OF BY THE CONTRACTOR AT HIS OWN RESPONSIBILITY OUTSIDE THE LIMITS OF THE HIGHWAY RIGHT OF WAY.

AN ADDITIONAL QUANTITY OF ASPHALT CONCRETE HAS BEEN SET UP TO BE USED IN THOSE AREAS EXCAVATED FOR DRIVEWAYS, MAILBOX AND BRIDGE APPROACHES.

ALL WORK, MATERIALS, EXCEPT ITEM 304, LABOR AND EQUIPMENT NECESSARY TO COMPLETE THE ABOVE DESCRIBED WORK SHALL BE INCIDENTAL TO THE PLACEMENT OF THE ASPHALT CONCRETE.

PERSONAL PROTECTION EQUIPMENT (PPE)

THE CONTRACTOR SHALL FOLLOW ALL REQUIREMENTS OF SECTIONS XXIV AND XXXIV OF THE OHIO DEPARTMENT OF TRANSPORTATION SAFETY & HEALTH STANDARD OPERATING PROCEDURE 220-006(SP) EFFECTIVE: NOVEMBER 1, 2018 (EXCEPT AS AMENDED BELOW) AND ALL SUBSEQUENT UPDATES POSTED AT THE FOLLOWING WEB SITE:

[HTTP://WWW.DOT.STATE.OH.US/POLICY/POLICIESANDSOPS/POLICIES/220-006\(SP\).PDF](http://www.dot.state.oh.us/policy/policiesandsops/policies/220-006(sp).pdf)

AMENDMENTS TO THE REQUIREMENTS OF THIS DOCUMENT ARE:

XXIV. HEAD PROTECTION (HARD HATS)

ALL PERSONS WITHIN THE RIGHT-OF-WAY OF ANY HIGHWAY OR ANY OTHER TYPE OF ROADWAY OR CONSTRUCTION SITE WHO ARE EXPOSED TO EITHER TRAFFIC (VEHICLES USING THE HIGHWAY FOR PURPOSES OF TRAVEL) OR CONSTRUCTION EQUIPMENT WITHIN THE WORK AREA, REGARDLESS OF JOB TYPE, SHALL WEAR APPROPRIATE HEAD PROTECTION. ALL HARD HATS MUST MEET OR EXCEED ANSI Z89.1-2009 TYPE I CLASS E-G REQUIREMENTS.

XXXIV. SAFETY APPAREL AND VEST (HIGH VISIBILITY)

ALL PERSONS WITHIN THE RIGHT-OF-WAY OF ANY HIGHWAY OR ANY OTHER TYPE OF ROADWAY OR CONSTRUCTION SITE WHO ARE EXPOSED TO EITHER TRAFFIC (VEHICLES USING THE HIGHWAY FOR PURPOSES OF TRAVEL) OR CONSTRUCTION EQUIPMENT WITHIN THE WORK AREA, REGARDLESS OF JOB TYPE, SHALL WEAR A HIGH-VISIBILITY SAFETY VEST THAT MEETS THE PERFORMANCE CLASS II OR CLASS III REQUIREMENTS OF THE ANSI/ISEA 107-2015 PUBLICATION ENTITLED "AMERICAN NATIONAL STANDARD FOR HIGH-VISIBILITY SAFETY APPAREL AND ACCESSORIES."

WORKERS MAY WEAR AN ANSI CLASS II OR ANSI CLASS III APPROVED RAIN SUIT, JACKET, OR OTHER APPAREL WITHOUT A SAFETY VEST OVER IT.

ENVIRONMENTAL COMMITMENT

ACTIVITIES AND LAND USE ADJACENT TO THIS PROJECT MAY BE AFFECTED BY CONSTRUCTION NOISE. IN ORDER TO MINIMIZE ANY ADVERSE CONSTRUCTION NOISE IMPACTS, THIS PROJECT MUST BE CONSTRUCTED IN ACCORDANCE WITH CONSTRUCTION NOISE ORDINANCES IN AFFECT FOR THE CITY OF KENTON, VILLAGE OF PATTERSON, AND VILLAGE OF FOREST. IF THE CONTRACTOR AND PROJECT ENGINEER DETERMINE THIS PROJECT CANNOT BE CONSTRUCTED IN ACCORDANCE WITH THE LOCAL CONSTRUCTION NOISE ORDINANCES, CITY OF KENTON CINDY MURRAY 419-674-4850, VILLAGE OF FOREST DEAN HANKINS 419-273-2500, VILLAGE OF PATTERSON 419-273-2213, MUST BE CONTACTED BY THE CONTRACTOR AT LEAST 48 HOURS IN ADVANCE OF THE WORK THAT WOULD VIOLATE THESE NOISE ORDINANCES. ADDITIONALLY, THE CONTRACTOR MUST ENSURE RESIDENTS/ AND OR BUSINESS OWNERS WITHIN A 500-FOOT RADIUS OF THE CONSTRUCTION NOISE WILL BE NOTIFIED PRIOR TO COMMENCEMENT OF THE WORK IN VIOLATION OF THESE NOISE ORDINANCES.

ITEM 202, WALK REMOVED, AS PER PLAN

IN ADDITION, TO THE REMOVAL OF EXISTING WALKS AND CURB RAMPS, ANY EXCAVATION REQUIRED FOR PLACEMENT OF PROPOSED PAVEMENT AND/OR CURB SHALL BE INCLUDE WITH THIS ITEM AND SHALL BE COMPLETED PER THE REQUIREMENTS OF CMS SECTION 203. THE COST FOR THIS ADDITIONAL WORK SHALL BE INCLUDED IN THE UNIT PRICE BID FOR ITEM 202, WALK REMOVED, AS PER PLAN.

NOTIFICATION OF TRAFFIC RESTRICTIONS

THROUGHOUT THE DURATION OF THE PROJECT, THE CONTRACTOR SHALL NOTIFY THE PROJECT ENGINEER IN WRITING OF ALL TRAFFIC RESTRICTIONS AND UPCOMING MAINTENANCE OF TRAFFIC CHANGES. THE CONTRACTOR SHALL ENSURE THE WRITTEN NOTIFICATION IS SUBMITTED IN A TIMELY MANNER TO ALLOW THE PROJECT ENGINEER TO MEET THE REQUIRED TIME FRAMES SET FORTH IN THE TABLE BELOW TO INFORM SPECIAL HAULING PERMITS SECTION (HAULING.PERMITS@DOT.OHIO.GOV) AND THE DISTRICT PUBLIC INFORMATION OFFICE (PIO). THIS NOTIFICATION SHALL BE RECEIVED BY THE PROJECT ENGINEER PRIOR TO THE PHYSICAL SETUP OF ANY APPLICABLE SIGNS OR MESSAGE BOARDS.

INFORMATION SHOULD INCLUDE, BUT IS NOT LIMITED TO, ALL CONSTRUCTION ACTIVITIES THAT IMPACT OR INTERFERE WITH TRAFFIC AND SHALL LIST THE SPECIFIC LOCATION, TYPE OF WORK, ROAD STATUS, DATE AND TIME OF RESTRICTION, DURATION OF RESTRICTION, NUMBER OF LANES MAINTAINED, NUMBER OF LANES CLOSED, MINIMUM VERTICAL CLEARANCE, MINIMUM WIDTH OF DRIVABLE PAVEMENT, DETOUR ROUTES, IF APPLICABLE, AND ANY OTHER INFORMATION REQUESTED BY THE PROJECT ENGINEER.

NOTIFICATION TIME TABLE

ITEM	DURATION OF CLOSURE	NOTICE DUE TO PERMITS & PIO
RAMP & ROAD CLOSURES	>= 2 WEEKS > 12 HOURS & < 2 WEEKS <= 12 HOURS	21 CALENDAR DAYS PRIOR TO CLOSURE 14 CALENDAR DAYS PRIOR TO CLOSURE 4 BUSINESS DAYS PRIOR TO CLOSURE
LANE CLOSURES & RESTRICTIONS	>= 2 WEEKS < 2 WEEKS	14 CALENDAR DAYS PRIOR TO CLOSURE 5 BUSINESS DAYS PRIOR TO CLOSURE
START OF CONSTRUCTION & TRAFFIC PATTERN CHANGES	N/A	14 CALENDAR DAYS PRIOR TO IMPLEMENTATION

ANY UNFORESEEN CONDITIONS NOT SPECIFIED IN THE PLANS REQUIRING TRAFFIC RESTRICTIONS SHALL ALSO BE REPORTED TO THE PROJECT ENGINEER USING THE NOTIFICATION TIME TABLE.

SEEDING AND MULCHING

THE FOLLOWING QUANTITIES ARE PROVIDED TO PROMOTE GROWTH AND CARE OF PERMANENT SEEDED AREAS:

659, SEEDING AND MULCHING	30 SQ. YD.
659, COMMERCIAL FERTILIZER	0.15 TON
659, WATER	4 M. GAL.

SEEDING AND MULCHING SHALL BE APPLIED TO ALL AREAS OF EXPOSED SOIL BETWEEN THE RIGHT-OF-WAY LINES, AND WITHIN THE CONSTRUCTION LIMITS FOR AREAS OUTSIDE THE RIGHT-OF-WAY LINES COVERED BY WORK AGREEMENT OR SLOPE EASEMENT. QUANTITY CALCULATIONS FOR SEEDING AND MULCHING ARE BASED ON THESE LIMITS.

ITEM 608, CURB RAMP, AS PER PLAN

CURB RAMP QUANTITY DOES NOT INCLUDE CURB. CURB WILL BE PAID FOR AS A SEPERATE ITEM MEASURED IN FEET.

SOME OF THE EXISTING CURB RAMPS IN THE VILLAGE OF FOREST HAVE A BRICK STAMPING AND HAVE A RED STAIN APPLIED TO THEM. THE NEW CURB RAMPS IN THESE AREAS WILL NOT HAVE A BRICK STAMPING BUT THEY WILL BE STAINED TO MATCH THE EXISTING COLOR OF STAIN. THIS OCCURS AT CURB RAMPS 15-R THRU 19-R AS SEEN ON SHEET 11 AND 12. CURB RAMP QUANTITY DOES NOT INCLUDE CURB. CURB WILL BE PAID FOR AS A SEPERATE ITEM MEASURED IN FEET.

IN ADDITION, THE THICKNESS OF PROPOSED CURB RAMPS SHALL BE PER SCD BP-7.1 UNLESS SHOWN AND/OR NOTE OTHERWISE IN THE PLANS. REFER TO THE CURB RAMP DETAILS IN THESE PLANS FOR ANY THICKNESS GREATER THAN WHAT IS NOTED IN SCD BP-7.1.

THE COST FOR ANY ADDITIONAL THICKNESS AND STAINING OF PROPOSED CONCRETE SHALL BE INCLUDED IN THE UNIT PRICE BID FOR ITEM 608, CURB RAMP, AS PER PLAN.

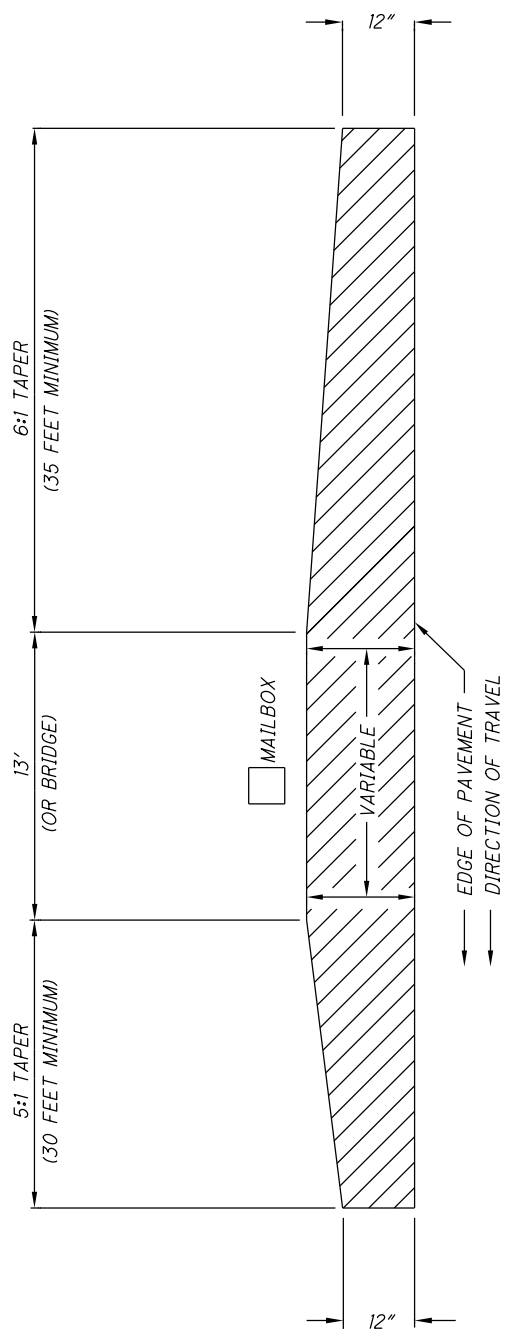

NOTE: ALL TOTALS CARRIED TO GENERAL SUMMARY

NOTE: MAILBOX AND DRIVE QUANTITIES ARE INCLUDED IN THE EXTRA AREAS

NOTE: DRAWINGS NOT TO SCALE

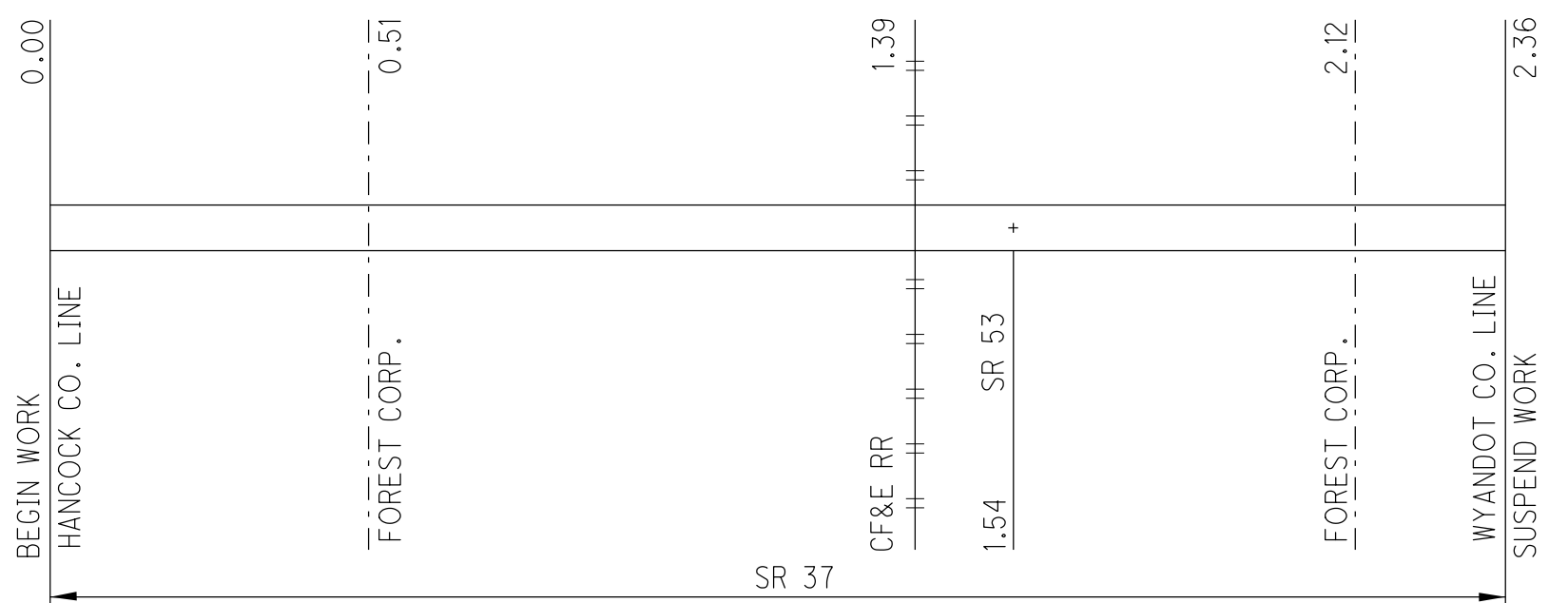
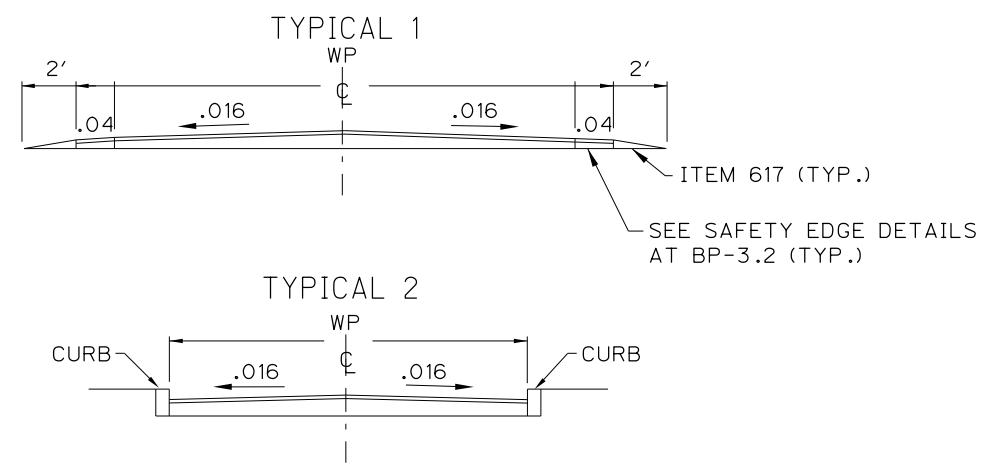

PAVEMENT DATA

ROUTE	FROM	TO	PLAN SPLITS	DISTANCE		PAVT WIDTH	TYPICAL SECTION	PAVT AREA	202		407	441		254		897		304	617	209	875	
									WEARING COURSE REMOVED		NON-TRACKING TACK COAT	ASPHALT CONCRETE SURFACE COURSE TYPE 1 (446)		ASPHALT CONCRETE SURFACE COURSE TYPE 1 (448)	PAVEMENT PLANING, ASPHALT CONCRETE	PATCHING PLANED SURFACES	CLASS A FINE PLANING	PATCHING PLANED SURFACES	AGGREGATE BASE	COMPACTED AGGREGATE	PREPARING SUBGRADE FOR SHOULDER PAVING	LONGITUDINAL JOINT ADHESIVE
									THICKNESS 1 1/2"	VARIABLE THICKNESS		THICKNESS 1 1/2"	QUANTITY USED FOR SAFETY EDGE	THICKNESS 1 1/2"	THICKNESS 1 1/2"	2% PLANED AREA	THICKNESS 1/2"	2% PLANED AREA	QUANTITY FOR DRIVEWAYS	2 INCH AVG. TH.		1 LB. PER 4 FT. (1 1/2" PAVE)
SLM	SLM			MILES	FEET	FEET		SY	SY	GAL	CY	CY	CY	SY	SY	SY	SY	CY	CY	MILE	LB	
Part 1																						
SR 37	0.00	0.51	01/STR/PV	0.51	2693	26	1	11818	231		1005	492	8				11818	236	5	66	1.02	673
SR 37	0.51	1.48	01/STR/PV	0.97	5122	26	1	22478		1911	937	15		22478	450			10	126	1.94	1280	
SR 37	1.48	1.51	01/STR/PV	0.03	158	40	2	704		60	29			704	14						40	
SR 37	1.51	1.54	01/STR/PV	0.03	158	48	2	845		72	35			845	17						40	
SR 37	1.54	1.70	01/STR/PV	0.16	845	50	2	4693		399	196			4693	94						211	
SR 37	1.70	1.84	01/STR/PV	0.14	739	31	2	2546		216	106			2546	51						185	
SR 37	1.84	2.12	01/STR/PV	0.28	1478	27	1	4435		377	185	4		4435	89			10	37	0.56	370	
SR 37	2.12	2.25	01/STR/PV	0.13	686	27	1	2059	120	175	86	2				2059	41		17	0.26	172	
SR 37	2.25	2.36	01/STR/PV	0.11	581	28	1	1807	125	154	75	2				1807	36		14	0.22	145	
Extra Areas								704	704	60				29								
Intersections								2214	1659	555	188			93								
Totals									2839	555	4617		2172	122	35701	715	15684	313	25	260	4.00	3116

ASPHALT CONCRETE

HAR-37 / 53-
0.00 / 1.34

I:\Project\data\07683\Design\Roadway\Sheets\07683_004.dgn Sheet 04-DEC-2020 1:56PM girwin

i:\Project\data\07683\Design\Roadway\Sheets\07683_005.dgn_Sheet_04-DEC-2020 1:56PM gir-win

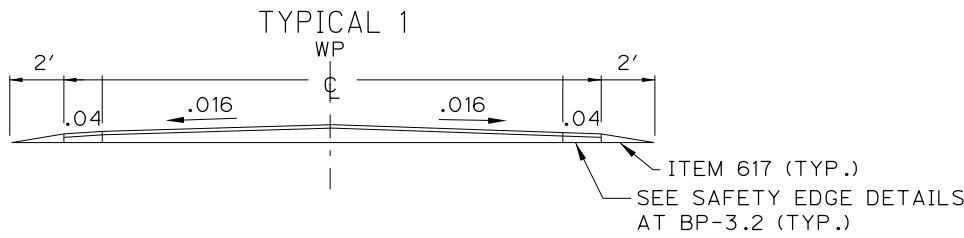

NOTE: ALL TOTALS CARRIED TO GENERAL SUMMARY

NOTE: MAILBOX AND DRIVE QUANTITIES ARE INCLUDED IN THE EXTRA AREAS

NOTE: DRAWINGS NOT TO SCALE

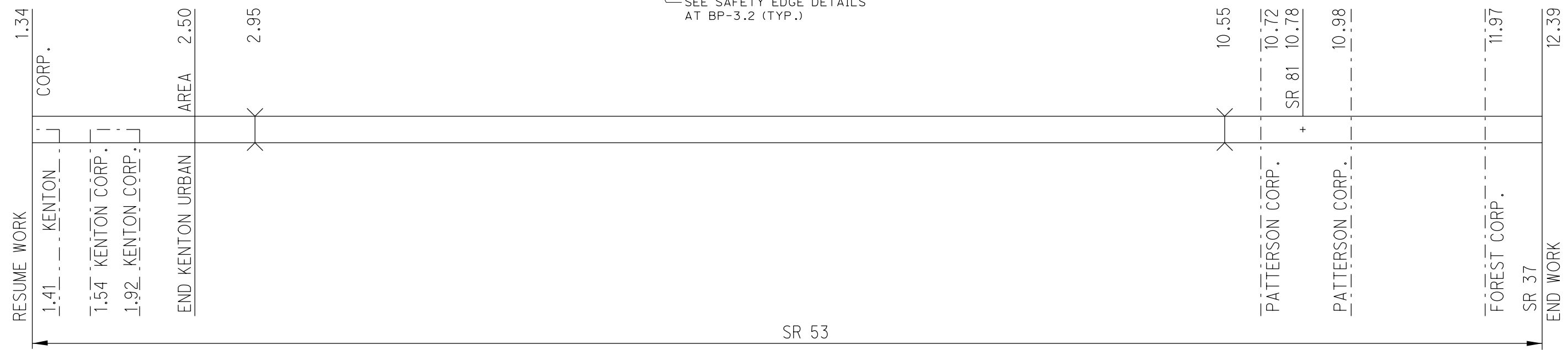

PAVEMENT DATA

ROUTE	FROM	TO	PLAN SPLITS	DISTANCE		PAVT WIDTH	TYPICAL SECTION	PAVT AREA	202		407	441		254		897		304	617	209	875			
				WEARING COURSE REMOVED	NON-TRACKING TACK COAT				ASPHALT CONCRETE SURFACE COURSE TYPE 1 (446)	ASPHALT CONCRETE SURFACE COURSE TYPE 1 (448)	PAVEMENT PLANING, ASPHALT CONCRETE	PATCHING PLANED SURFACES	CLASS A FINE PLANING	PATCHING PLANED SURFACES	AGGREGATE BASE	COMPACTED AGGREGATE	PREPARING SUBGRADE FOR SHOULDER PAVING	LONGITUDINAL JOINT ADHESIVE						
				THICKNESS 1 1/2"	VARIABLE THICKNESS				THICKNESS 1 1/2"	QUANTITY USED FOR SAFETY EDGE	THICKNESS 1 1/2"	2% PLANED AREA	THICKNESS 1/2"	2% PLANED AREA	QUANTITY FOR DRIVEWAYS	2 INCH AVG. TH.		1 LB. PER 4 FT. (1 1/2" PAVE)						
SLM	SLM			MILES	FEET	FEET	SY	SY	SY	GAL	CY			SY	SY	SY	SY	CY	CY	MILE	LB			
Part 2																								
SR 53	1.34	1.41	03/S<2/PV/KENT	0.07	370	12 *	1	493	54		42	21	1				493	10		5	0.07	46		
SR 53	1.54	1.92	03/S<2/PV/KENT	0.38	2006	12 *	1	2675		227	111	3					2675	54	5	25	0.38	251		
Extra Areas								88	88		7	4												
Intersections								190	190		16			8										
Subtotals Plan Split 03									142	190	292		140				3168	64	5	30	0.45	297		
SR 53	1.34	1.41	02/S<2/PV	0.07	370	12 *	1	493	54		42	21	1				493	10		5	0.07	46		
SR 53	1.41	1.54	02/S<2/PV	0.13	686	24	1	1830		156	76	2					1830	37		17	0.26	172		
SR 53	1.54	1.92	02/S<2/PV	0.38	2006	12 *	1	2675		227	111	6					2675	54		25	0.38	251		
SR 53	1.92	2.50	02/S<2/PV	0.58	3062	24	1	8166		694	340	9					8166	163	5	76	1.16	766		
Extra Areas								72	72		6	3												
Intersections								258	258		22			11										
Subtotals Plan Split 02									384	1147		569				13164	264	5	123	1.87	1235			
SR 53	2.50	2.87	01/STR/PV	0.37	1954	24	1	8574		729	357	6					8574	171		48	0.74	488		
SR 53	2.87	2.94	01/STR/PV	0.07	370	29.5	1	1211	132		103	50	1				1211	24		9	0.14	92		
SR 53	2.94	2.96	bridge																					
SR 53	2.96	3.06	01/STR/PV	0.10	528	29.5	1	1731	132		147	72	2				1731	35		13	0.20	132		
SR 53	3.06	6.50	01/STR/PV	3.44	18163	24	1	48435		4117	2018	53					48435	969	20	448	6.88	4541		
SR 53	6.50	7.00	01/STR/PV	0.50	2640	29	1	8507		723	354	8					8507	170		65	1.00	660		
SR 53	7.00	7.25	01/STR/PV	0.25	1320	28	1	4107		349	171	4					4107	82		33	0.50	330		
SR 53	7.25	10.54	01/STR/PV	3.29	17371	24	1	46323	107		3937	1930	50				46323	926	20	429	6.58	4343		
SR 53	10.54	10.56	bridge																					
SR 53	10.56	10.72	01/STR/PV	0.16	845	24	1	2253	214		191	94	2				2253	45		21	0.32	211		
SR 53	10.72	10.98	01/STR/PV	0.26	1373	24	1	3661			311	153	4		3661	73				34	0.52	343		
SR 53	10.98	11.97	01/STR/PV	0.99	5227	24	1	13939	214		1185	581	15				13939	279	10	129	1.98	1307		
SR 53	11.97	12.39	01/STR/PV	0.42	2218	24	1	5914			503	246	6		5914	118				55	0.84	554		
Extra Areas								960	960		82	40												
Intersections								4701	1331	3370	400			196										
Subtotals Plan Split 01									3090	3370	12777		6217			196	9575	191	135080	2701	50	1284	19.70	13001
Totals									3616	3560	14216		6926			215	9575	191	151412	3029	60	1437	22.02	14533

CALCULATED GLI CHECKED EJS
ASPHALT CONCRETE
 HAR-37 / 53- 0.00 / 1.34
 5 / 16

Ref. No.	Intersecting Street	Side	Quantities										Dimensions				
			202			608						609	Ramp		Landing		
			Walk Removed	Walk Removed, As Per Plan	Curb Removed	4" Concrete Walk	Curb Ramp B3 As Per Plan	Curb Ramp A1 As Per Plan	Curb Ramp C2 As Per Plan	Curb Ramp A2 As Per Plan	Curb Ramp A1/A2 Combo As Per Plan	Detectable Warning	Curb	Width	Length	Width	Length
			SF	SF	FT	SF	SF	SF	SF	SF	SF	SF	FT	FT	FT	FT	FT
1-R	SR 37 and Gage St.	Rt.				60											
2-R		Lt.				24											
3-R		Lt.	20			20											
4-R		Lt.				50											
5-R	SR 37 and Smith St.	Lt.	23			50											
6-R		Rt.	28			28											
7-R		Lt.	116			130											
8-R	SR 37 and Martin St.	Rt.	32			88											
9-R		Rt.	49		6	49						6					
10-R		Rt.	131			131											
11-R	SR 37 and Davis St.	Rt.				34											
12-R		Rt.	43			43											
13-R		Rt.	30			30											
14-R	SR 37 and SR 53	Rt.	135		8		69					8	9	8			
15-R		Rt.		194	20		89					26	9 - 8	7			
16-R	SR 37 and Patterson St.	Rt.	108		20	43		65				20	4	6	4	4	
17-R		Rt.	140		22	75		65				22	4	6	4	4	
18-R	SR 37 and Gormley St.	Rt.	290		40	192				98		40	4	4	4	4	
19-R		Lt.	288		20				288				20	11	11	7	11
20-R	SR 37 and Warner St.	Rt.	81			81						16					
21-R		Lt.	23			23						10					
22-R		Rt.	25			25						10					
23-R		Lt.	24			24						10					
24-R	SR 37 and Mary St.	Rt.	107		7				107			10	7	5	9	4	5
25-R		Lt.	23			23						10					
26-R		Rt.	190		7					190			7	5	12	5	5
27-R		Lt.	20			20						8					
28-R		Lt.	23		7					23			7	5	5		
29-R	SR 37 and Speidle St.	Rt.	50			50						8					
Totals			1999	194	157	1293	158	130	288	320	98	214	163				

CURB RAMP SUB-SUMMARY

HAR-37 / 53-
0.00 / 1.34

I:\Project\data\07683\Design\Roadway\Sheets\07683_008.dgn Sheet 04-DEC-2020 1:56PM gir-win

Ref. No.	Intersecting Street	Side	Quantities			
			202	608		
			Walk Removed	4" Concrete Walk	6" Concrete Walk	Detectable Warning
			SF	SF	SF	SF
30-R	SR 53 and SR 81	Rt.	27	109		17
31-R		Rt.	50	134		18
32-R	SR 53 and Hueston St.	Rt.	20		72	8
33-R		Rt.	30	80		8
34-R	SR 53 and Zimmerman St.	Rt.	20	20		8
35-R		Rt.		72		8
36-R	SR 53 and Dixon St.	Lt.	20	20		10
37-R		Rt.	24	24		10
Totals			191	459	72	87

Village of Forest

Village of Forest



Item 608, Curb Ramp, As per Plan,
Minimum of 8" Thick
See note on sheet 3

Curb Ramp Misc.
See note on sheet 3

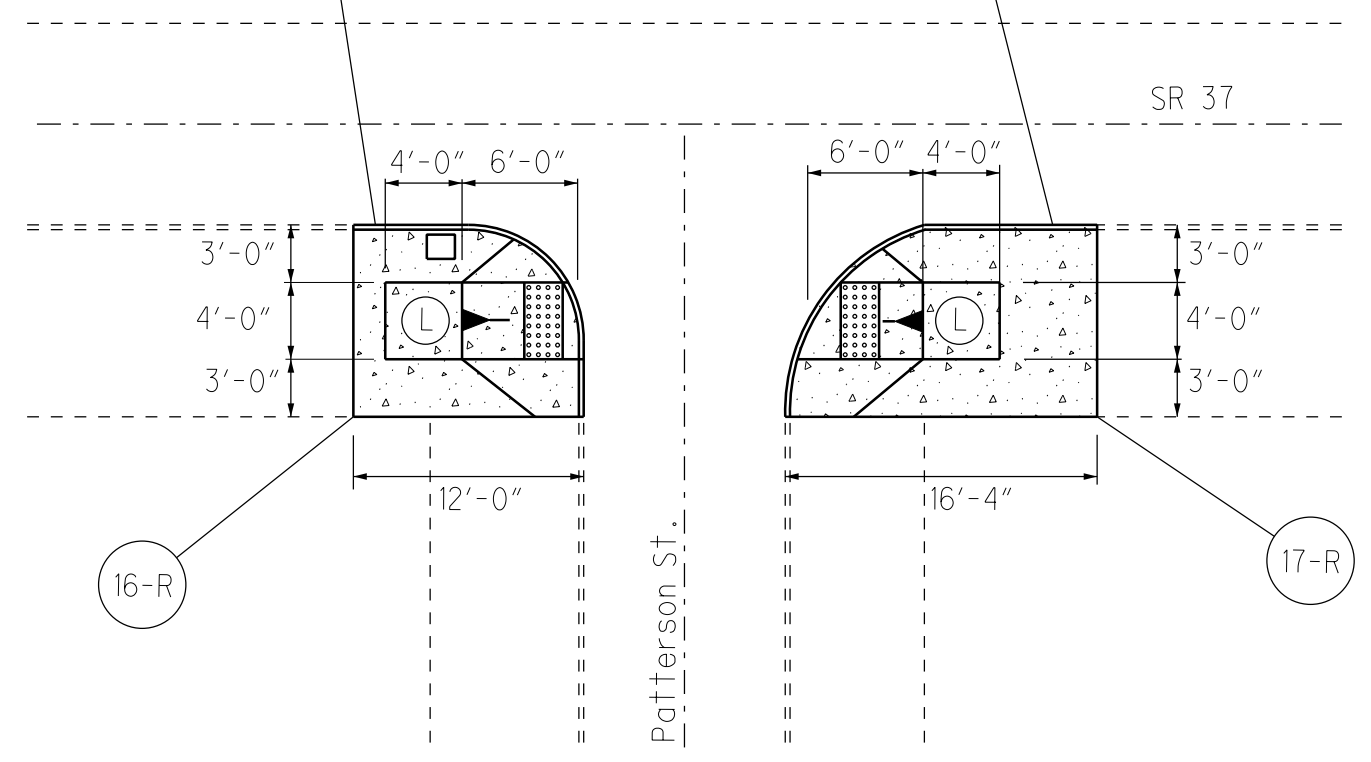
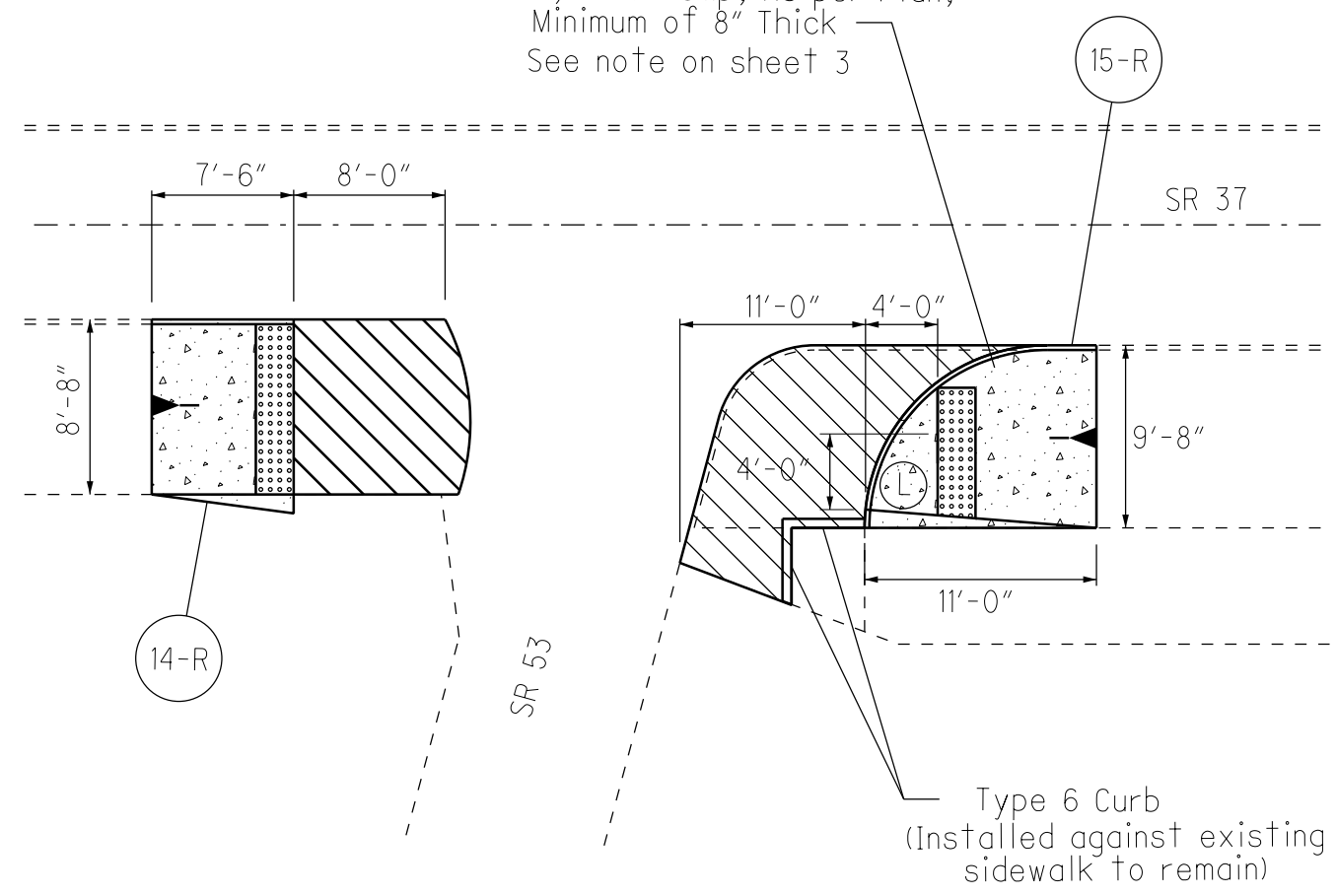
Curb Ramp Misc.
See note on sheet 3



 Remove sidewalk and curb in this area and replace with Item 253, Pavement Repair, minimum 9" thick, and a surface course of Item 441, AC, Surface Course, Type 1 (446), 1 1/2" Thick

- Not To Scale
-  - Detectable Warning
-  - Landing

CURB RAMP DETAILS

HAR-37 / 53-
0.00 / 1.34

I:\Project\data\07683\Design\Roadway\Sheets\07683_01.dgn Sheet 04-DEC-2020 1:56PM girwin

I:\Project\07683\Design\Roadway\Sheets\07683_016.dgn Sheet 04-DEC-2020 1:56PM gfrwin

SHEET NUM.								PART.			ITEM	ITEM EXT	GRAND TOTAL	UNIT	DESCRIPTION	SEE SHEET NO.
2	3	4	5	6	8	14	01/STR/P V	02/S<2/P V	03/S<2/P V/KENT							
ROADWAY																
		3,394	7,176		2,190		9,854	384	332	202	23500	10,570	SY	WEARING COURSE REMOVED		
					194		2,190			202	30000	2,190	SF	WALK REMOVED		
					157		194			202	30001	194	SF	WALK REMOVED, AS PER PLAN	3	
						1	157			202	32000	157	FT	CURB REMOVED		
							1			203	20000	1	CY	EMBANKMENT		
		4	22.02		1,752		23.7	1.87	0.45	209	72050	26.02	MILE	PREPARING SUBGRADE FOR SHOULDER PAVING		
					72		1,752			608	10000	1,752	SF	4" CONCRETE WALK		
					994		72			608	13000	72	SF	6" CONCRETE WALK		
					301		994			608	52001	994	SF	CURB RAMP, AS PER PLAN	3	
							301			608	53020	301	SF	DETECTABLE WARNING		
					163		163			609	26000	163	FT	CURB, TYPE 6		
							6			623	39500	6	EACH	MONUMENT BOX ADJUSTED TO GRADE		
EROSION CONTROL																
						1	1			659	00300	1	CY	TOPSOIL		
	30						30			659	10000	30	SY	SEEDING AND MULCHING		
	0.15						0.15			659	20000	0.15	TON	COMMERCIAL FERTILIZER		
	4						4			659	35000	4	MGAL	WATER		
							1,000			832	30000	1,000	EACH	EROSION CONTROL		
DRAINAGE																
						15	15			611	04600	15	FT	12" CONDUIT, TYPE C		
						1	1			611	98700	1	EACH	INLET, SIDE DITCH		
PAVEMENT																
403							371	16	16	253	02000	403	CY	PAVEMENT REPAIR		
		35,701	9,575				45,276			254	01000	45,276	SY	PAVEMENT PLANING, ASPHALT CONCRETE, 1.5" DEPTH		
		715	191				906			254	01600	906	SY	PATCHING PLANED SURFACE		
		25	60				75	5	5	304	20000	85	CY	AGGREGATE BASE		
		4,617	14,216				17,394	1,147	292	407	20000	18,833	GAL	NON-TRACKING TACK COAT		
		2,172	6,926				8,389	569	140	441	10000	9,098	CY	ASPHALT CONCRETE SURFACE COURSE, TYPE 1, (446), PG64-22		
		122	215				318	11	8	441	50000	337	CY	ASPHALT CONCRETE SURFACE COURSE, TYPE 1, (448), PG64-22		
		260	1,437				1,544	123	30	617	10100	1,697	CY	COMPACTED AGGREGATE		
				0.49			0.49			618	41000	0.49	MILE	RUMBLE STRIPES, EDGE LINE (ASPHALT CONCRETE)		
		3,116	14,533				16,117	1,235	297	875	10000	17,649	LB	LONGITUDINAL JOINT ADHESIVE		
		15,684	151,412				150,764	13,164	3,168	897	01010	167,096	SY	PAVEMENT PLANING, ASPHALT CONCRETE, CLASS A, 0.5" DEPTH		
		313	3,029				3,014	264	64	897	02000	3,342	SY	PATCHING PLANED SURFACE		
TRAFFIC CONTROL																
				786			707	63	16	621	00100	786	EACH	RPM		
				786			707	63	16	621	54000	786	EACH	RAISED PAVEMENT MARKER REMOVED		
				26.13			23.81	1.87	0.45	642	00104	26.13	MILE	EDGE LINE, 6", TYPE 1		
				13.42			12.25	0.94	0.23	642	00300	13.42	MILE	CENTER LINE, TYPE 1		
				156			156			643	00500	156	FT	STOP LINE		
				468			468			643	00600	468	FT	CROSSWALK LINE		
				496			496			643	00800	496	FT	CURB MARKING		
				2			2			643	01000	2	EACH	RAILROAD SYMBOL MARKING		
				668			668			643	01200	668	FT	PARKING LOT STALL MARKING		
MAINTENANCE OF TRAFFIC																
82							68	10	4	614	12460	82	EACH	WORK ZONE MARKING SIGN		
13.42							12.25	0.94	0.23	614	21000	13.42	MILE	WORK ZONE CENTER LINE, CLASS I		
26.84							24.5	1.88	0.46	614	21400	26.84	MILE	WORK ZONE CENTER LINE, CLASS II		
INCIDENTALS																
							LS			614	11000	LS		MAINTAINING TRAFFIC		
							LS			624	10000	LS		MOBILIZATION		

GENERAL SUMMARY

**HAR-37 / 53-
0.00 / 1.34**