

NOTES:

- 1. ALL QUANTITIES CARRIED TO SHEET 12

LOCATION	ITEM	DESCRIPTION	UNIT	QUANTITY		TOTAL
				LEFT	RIGHT	
Ⓜ	202	BRIDGE TERMINAL ASSEMBLY REMOVED FOR REUSE	EACH		1	1
▨	203	EMBANKMENT, AS PER PLAN	CY	9	8	17
Ⓩ	606	BRIDGE TERMINAL ASSEMBLY REBUILT, TYPE 4	EACH		1	1

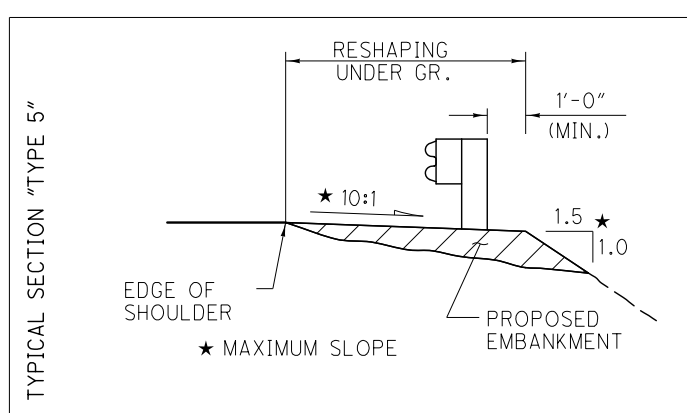

I:\projects\88767\roadway\sheets\88767GR001.dgn