

THE ABOVE QUANTITY IS BASED ON A 301 THICKNESS OF 9 INCHES AND A WIDTH OF TWO FEET AROUND THE PERIMETER OF THE DRAINAGE STRUCTURE. PROVIDE ANY MATERIALS USED OUTSIDE THE LIMITS STATED ABOVE AT NO ADDITIONAL COST.

**ITEM SPECIAL – TRASH RECEPTACLE TO BE REMOVED, STORED AND REINSTALLED:**

CONTRACTOR SHALL REMOVE AND STORE ALL TRASH RECEPTACLES WITHIN THE PROJECT LIMITS. UPON COMPLETION OF THE PROJECT, CONTRACTOR SHALL INSTALL TRASH RECEPTACLES AS DIRECTED BY THE ENGINEER.

ITEM 900 – SPECIAL: TRASH RECEPTACLE TO BE REMOVED, STORED AND REINSTALLED 4 EA

**ITEM SPECIAL – OHIO PUBLIC WORKS COMMISSION SIGN**

CONTRACTOR TO PLACE SIGNS AS DIRECTED BY ENGINEER.

ITEM 900 – SPECIAL: OPWC SIGN 2 EA

**RAILROAD NOTES:**

**RR 1** ALL WORK ON, OVER, UNDER, OR ADJACENT TO NORFOLK SOUTHERN RIGHT-OF-WAY SHALL BE DONE IN ACCORDANCE WITH THE NORFOLK SOUTHERN "SPECIAL PROVISIONS FOR THE PROTECTION OF RAILWAY INTEREST".

**RR 2** "ONE CALL" SERVICES DO NOT LOCATE BURIED RAILROAD SIGNAL AND COMMUNICATION LINES. THE CONTRACTOR SHALL CONTACT THE RAILROAD'S REPRESENTATIVE TWO (2) DAYS IN ADVANCE OF THOSE PLACES WHERE EXCAVATION, PILE DRIVING, OR HEAVY LOADS MAY DAMAGE RAILROAD UNDERGROUND LINES ON RAILROAD PROPERTY. UPON REQUEST FROM THE CONTRACTOR OR AGENCY, RAILROAD SIGNAL FORCES WILL LOCATE AND PAINT MARK OR FLAG RAILROAD UNDERGROUND SIGNAL, COMMUNICATION, AND POWER LINES IN THE AREA TO BE DISTURBED FOR THE CONTRACTOR. THE CONTRACTOR SHALL AVOID EXCAVATION OR OTHER DISTURBANCE OF THESE LINES WHICH ARE CRITICAL TO THE SAFETY OF THE RAILROAD AND THE PUBLIC. IF DISTURBANCE OR EXCAVATION IS REQUIRED NEAR A BURIED RAILROAD SIGNAL, COMMUNICATION, OR POWER LINE, THE LINE SHALL BE POTHOLED MANUALLY WITH CAREFUL HAND EXCAVATION BY THE CONTRACTOR AND PROTECTED BY THE CONTRACTOR DURING THE COURSE OF THE DISTURBANCE UNDER THE SUPERVISION AND DIRECTION OF A RAILROAD SIGNAL REPRESENTATIVE.

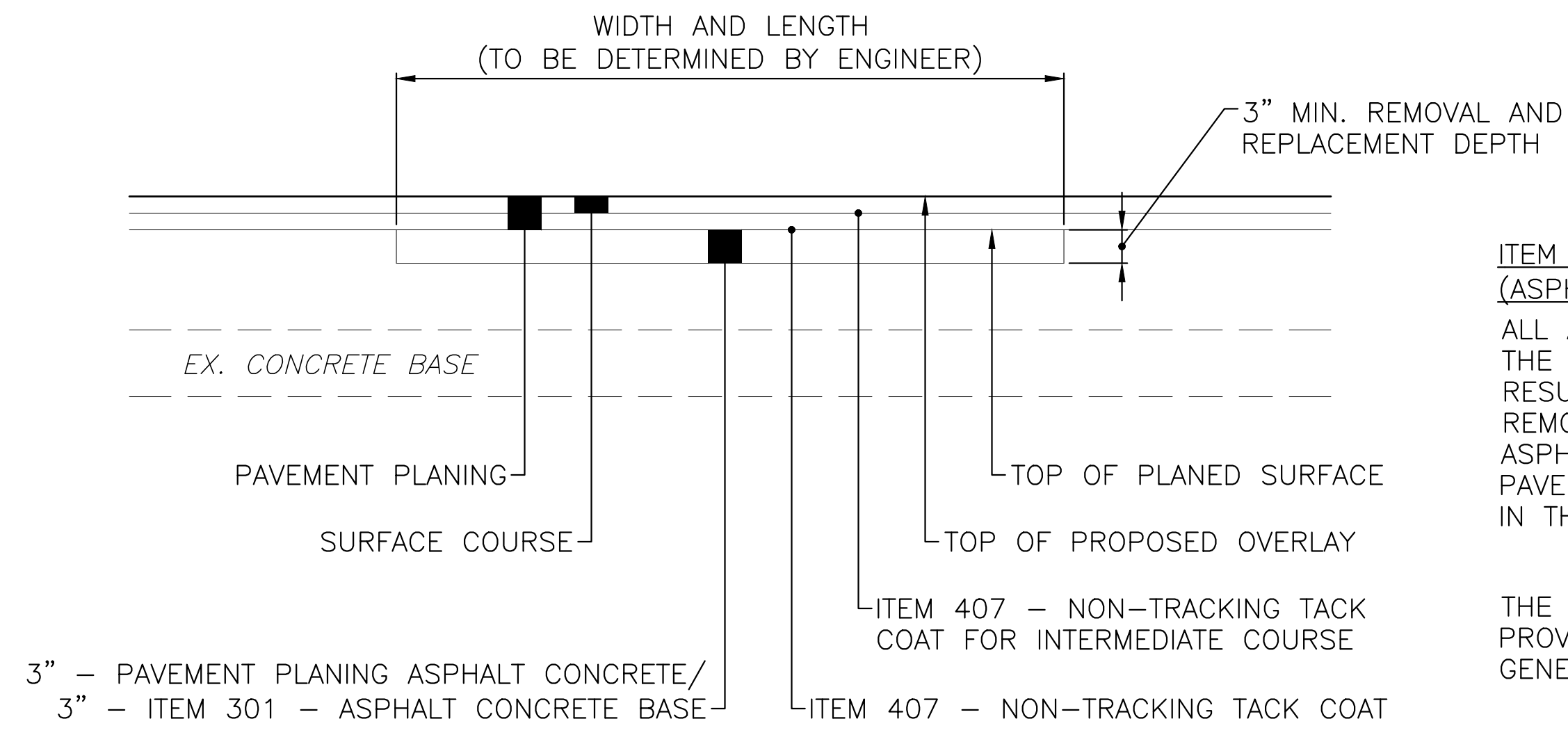

**PARTIAL DEPTH PAVEMENT REPAIR SECTION**

SCALE: 1" = 1'

**ITEM 251 – PARTIAL DEPTH PAVEMENT REPAIR (ASPHALT CONCRETE BASE), TYPE A, AS PER PLAN:**  
ALL AREAS TO BE REPAIRED SHALL BE LOCATED BY THE ENGINEER AND THE WORK PERFORMED PRIOR TO RESURFACING. REPAIR AREAS SHALL CONSIST OF REMOVING 3" OF PAVEMENT AND PLACING 3" ITEM 301 ASPHALT CONCRETE BASE, PG64-22. PARTIAL DEPTH PAVEMENT REPAIR SHALL BE STARTED AND COMPLETED IN THE SAME WORKING DAY.

THE FOLLOWING CONTINGENCY QUANTITY HAS BEEN PROVIDED AND THE TOTAL HAS BEEN CARRIED TO THE GENERAL SUMMARY.

ITEM 251 – PARTIAL DEPTH PAVEMENT REPAIR, (ASPHALT CONCRETE BASE), AS PER PLAN 150 SY

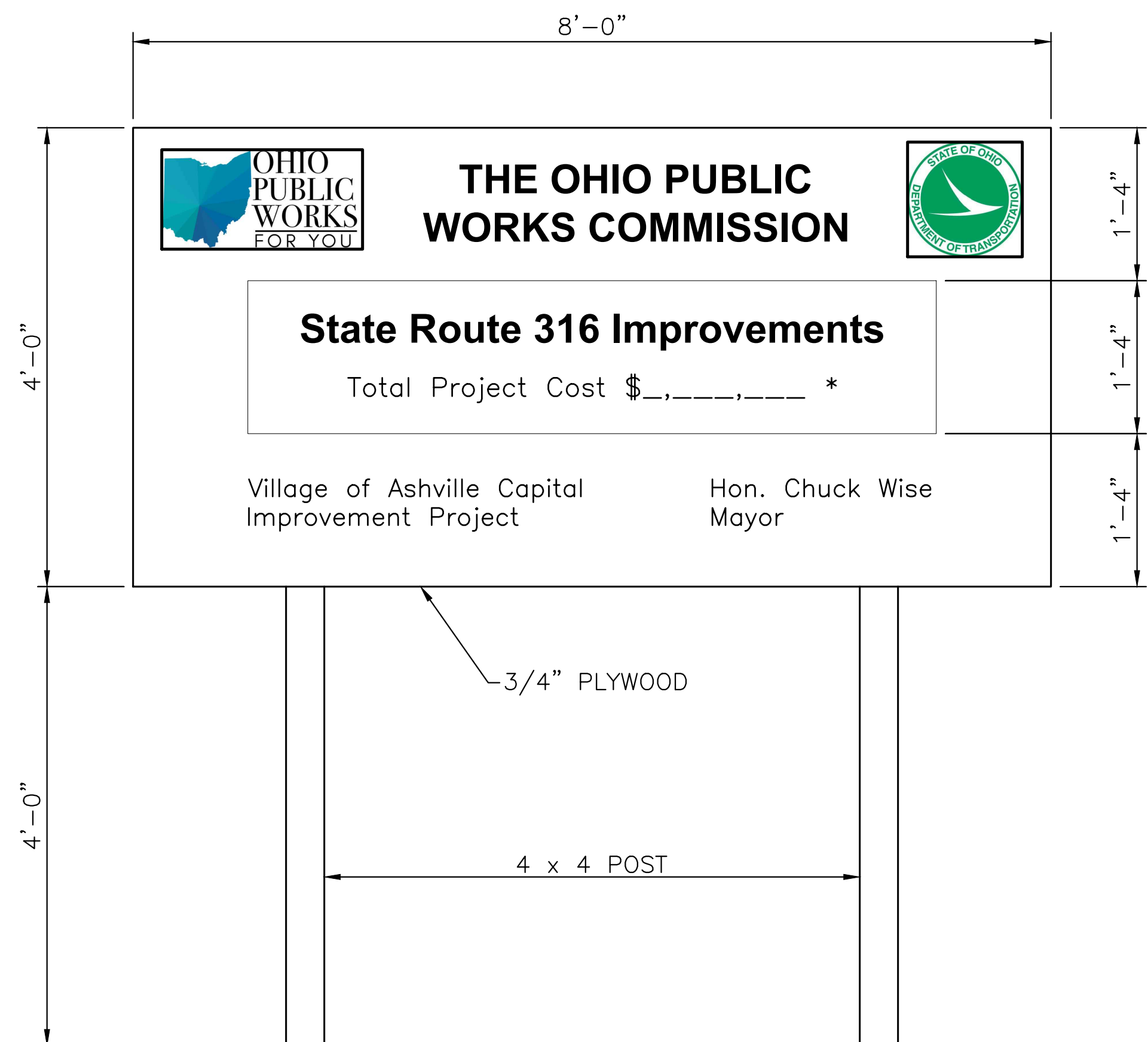

COLOR SPECIFICATIONS: 10% SCREEN OF PANTONE MATCHING SYSTEM 548 DARK BLUE FOR THE STATE OF OHIO GRAPHIC, PANTONE MATCHING SYSTEM 448 DARK BLUE FOR OHIO PUBLIC WORKS COMMISSION, PROJECT NAME, AND TOTAL PROJECT COST. BLACK WILL BE USED FOR THE BOX AROUND THE PROJECT NAME, TOTAL PROJECT COST, AND LOCAL PROJECT INFORMATION.

\* – TOTAL PROJECT COST SHALL BE THE BID COST FOR PART 2 ONLY

**ITEM SPECIAL - PROJECT SIGN**

SCALE: 1" = 1'

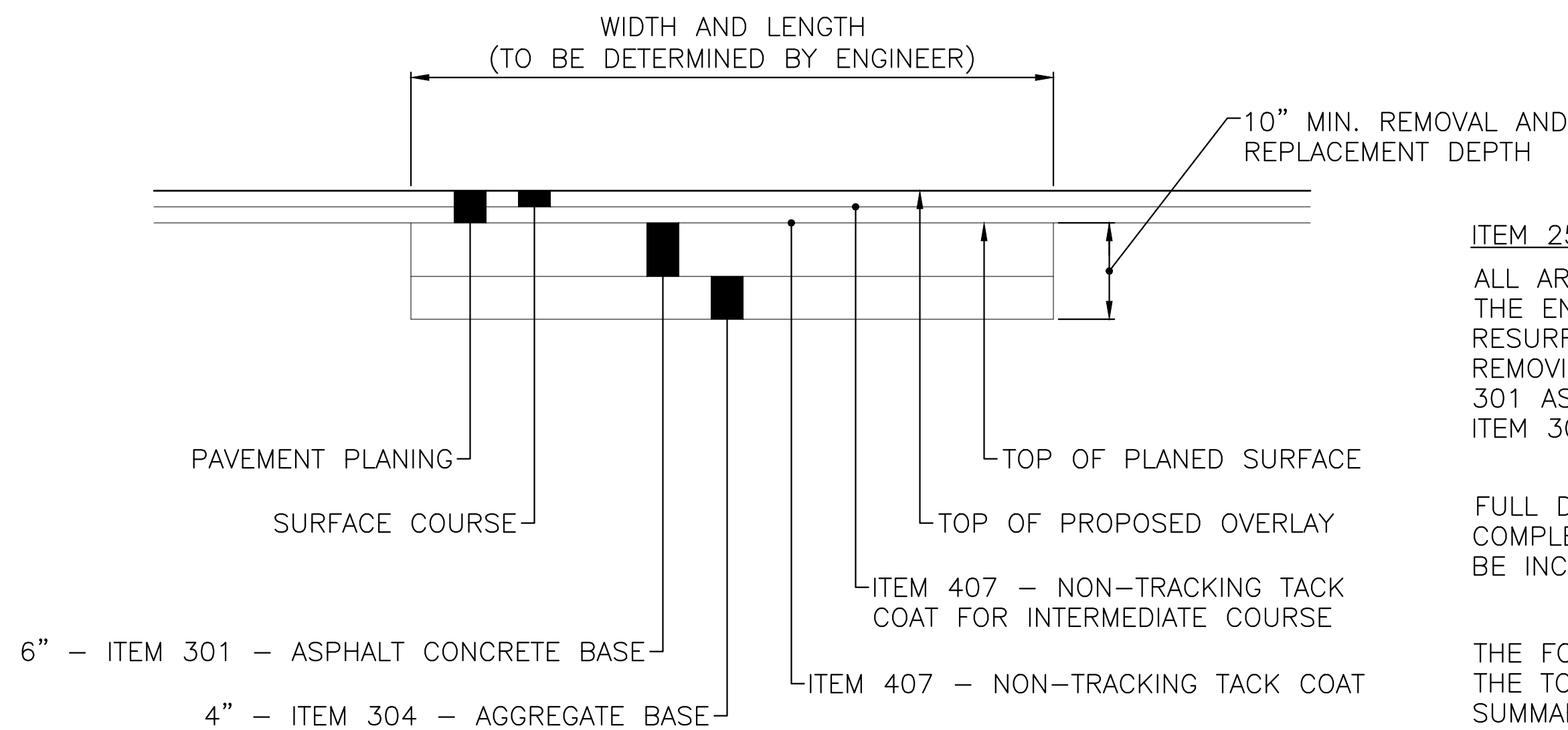

**PAVEMENT REPAIR SECTION**

SCALE: 1" = 1'

**ITEM 253 – PAVEMENT REPAIR, AS PER PLAN:**  
ALL AREAS TO BE REPAIRED SHALL BE LOCATED BY THE ENGINEER AND THE WORK PERFORMED PRIOR TO RESURFACING. REPAIR AREAS SHALL CONSIST OF REMOVING 10" OF PAVEMENT AND PLACING 6" OF ITEM 301 ASPHALT CONCRETE BASE, PG64-22 AND 4" OF ITEM 304 AGGREGATE BASE.

FULL DEPTH PAVEMENT REPAIR SHALL BE STARTED AND COMPLETED IN THE SAME WORKING DAY. SAWCUT SHALL BE INCIDENTAL TO THIS ITEM.

THE FOLLOWING QUANTITY HAS BEEN PROVIDED AND THE TOTAL HAS BEEN CARRIED TO THE GENERAL SUMMARY.

ITEM 253 – PAVEMENT REPAIR, AS PER PLAN 300 SY

CALCULATED  
CHECKED

GENERAL NOTES

PIC-316 - 13.05-13.68  
PART 2

66

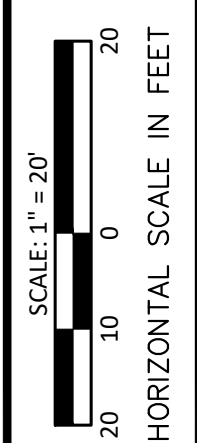
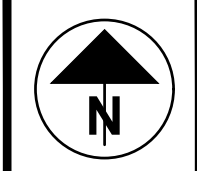

CALCULATED  
CHECKED

**STORM SEWER PROFILES**

**PIC-316 - 13.05-13.68  
PART 2**

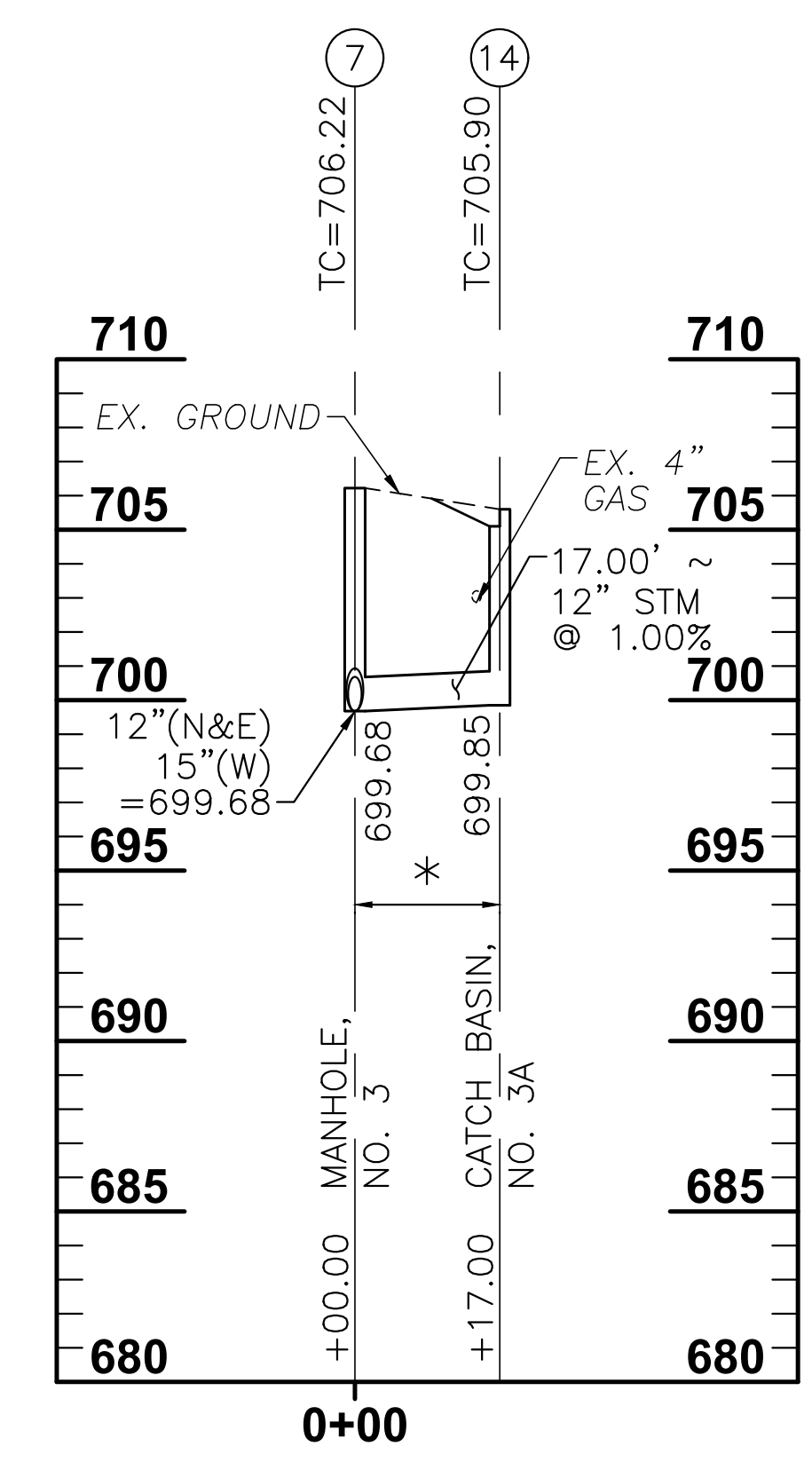
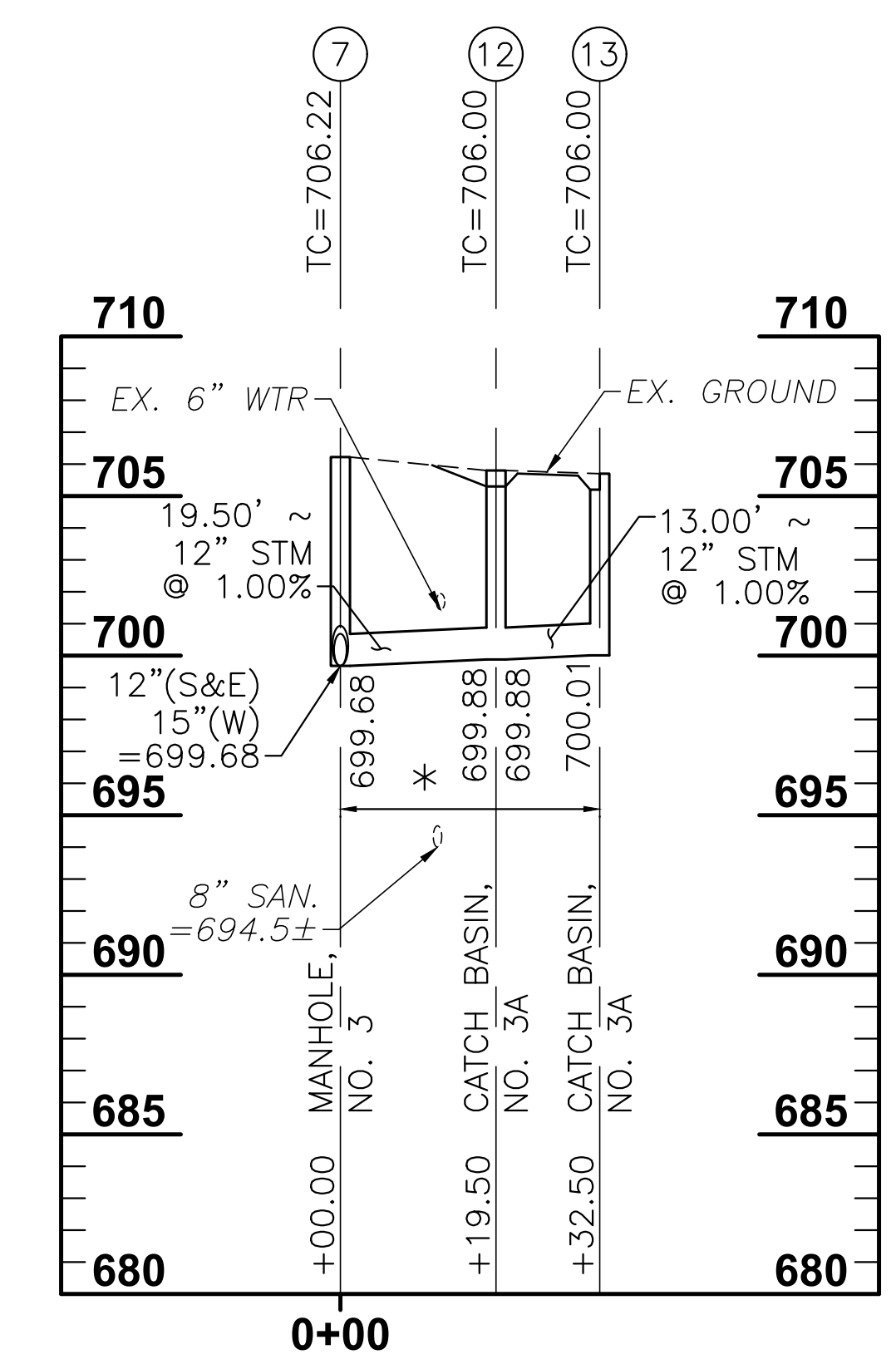
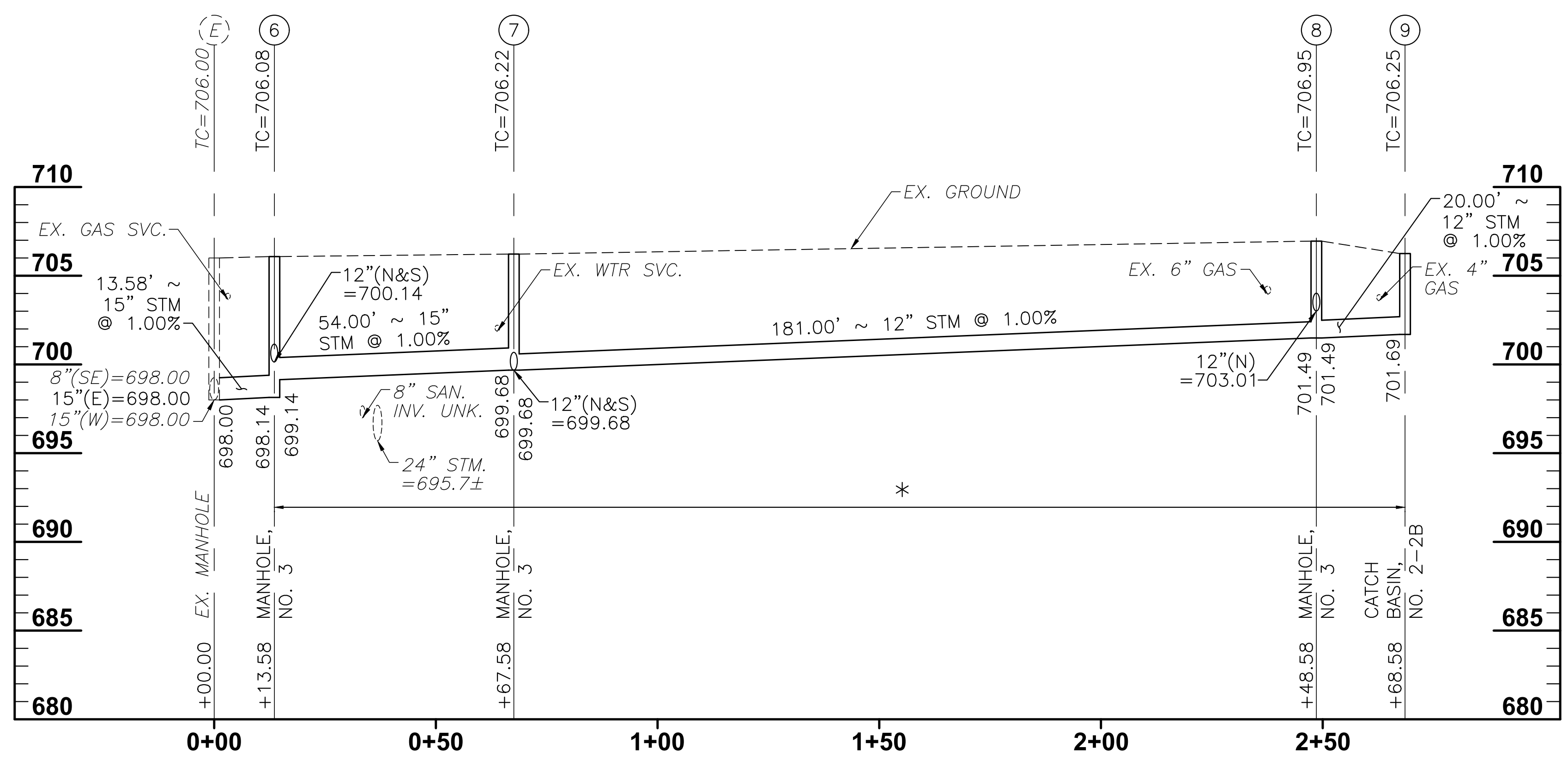
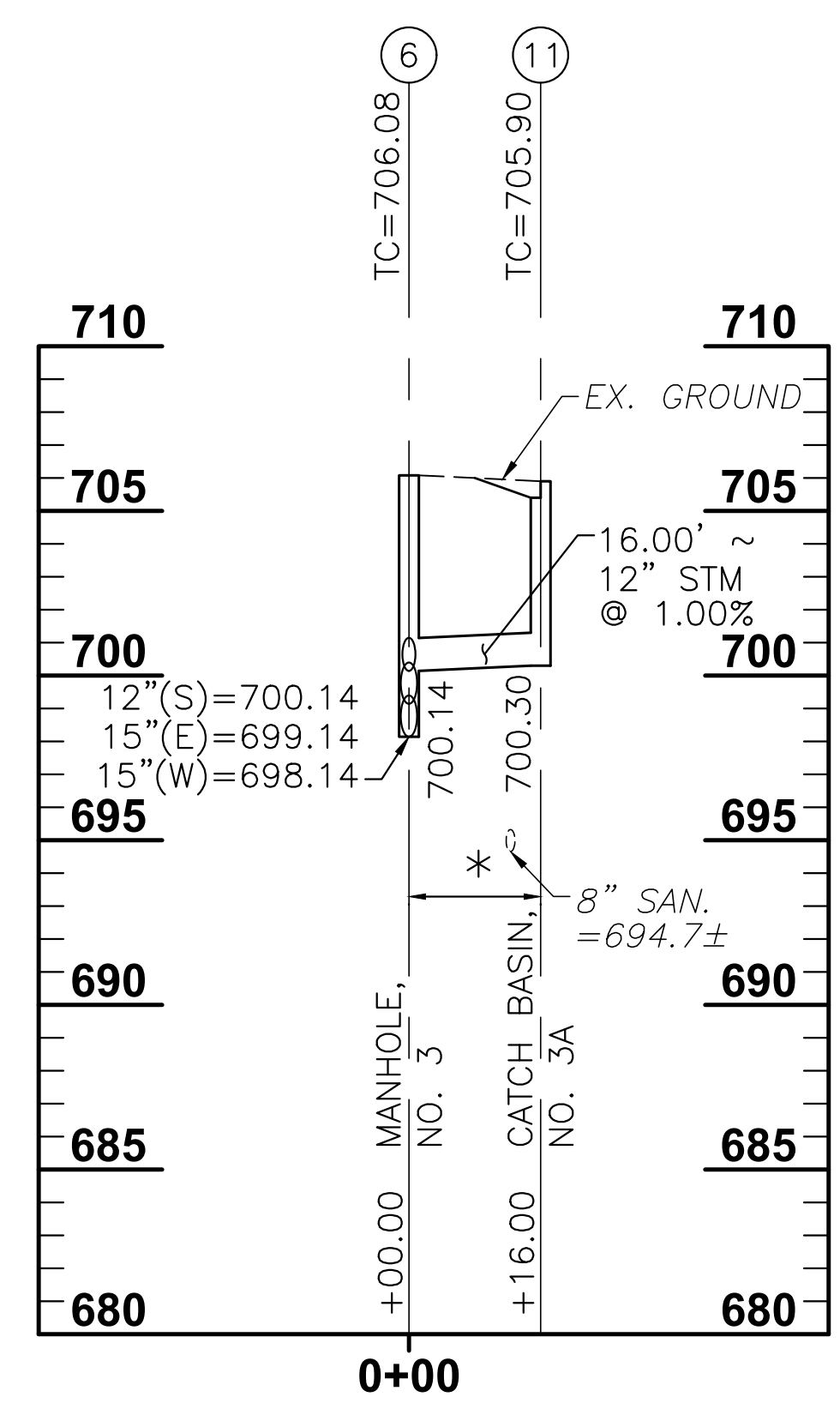
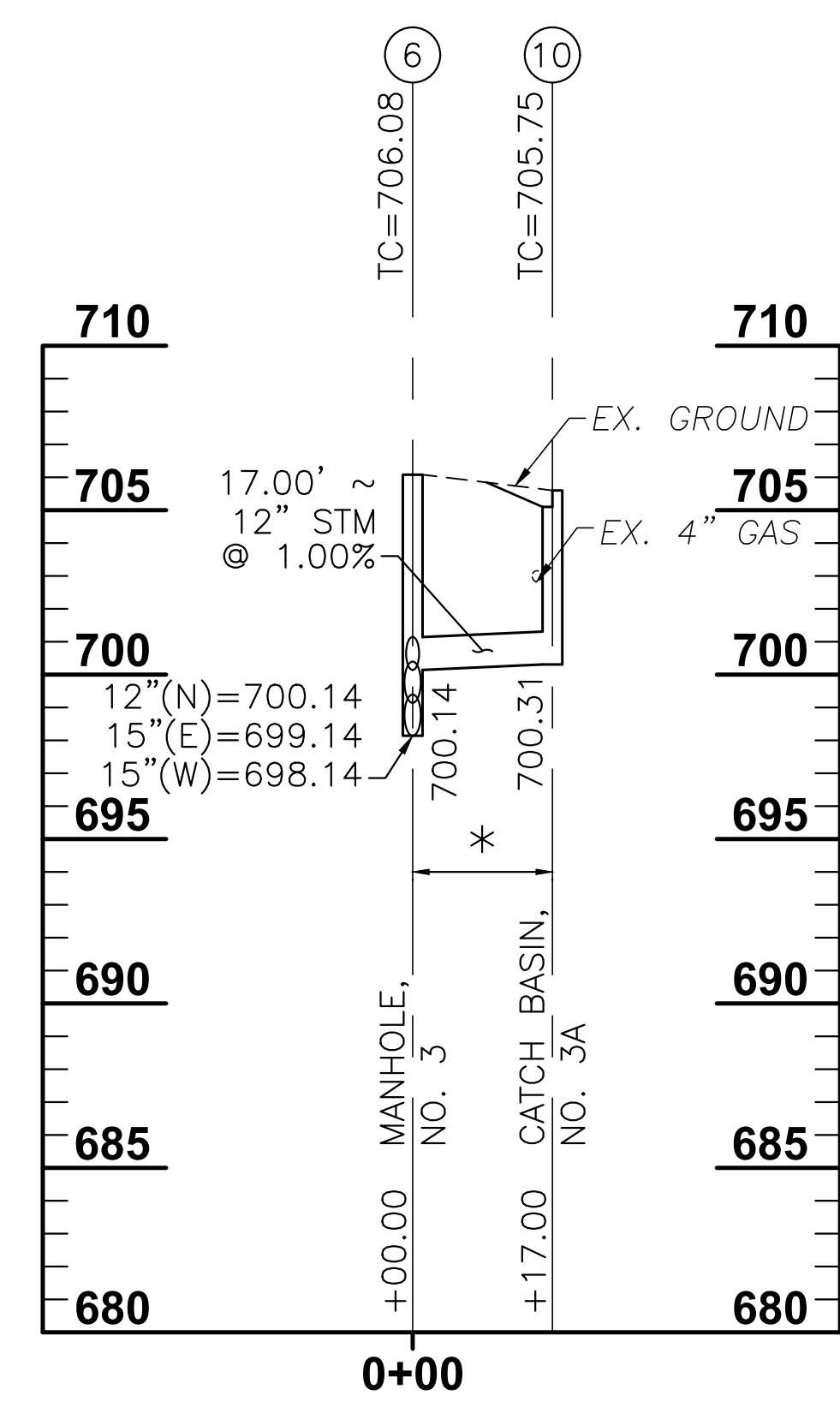
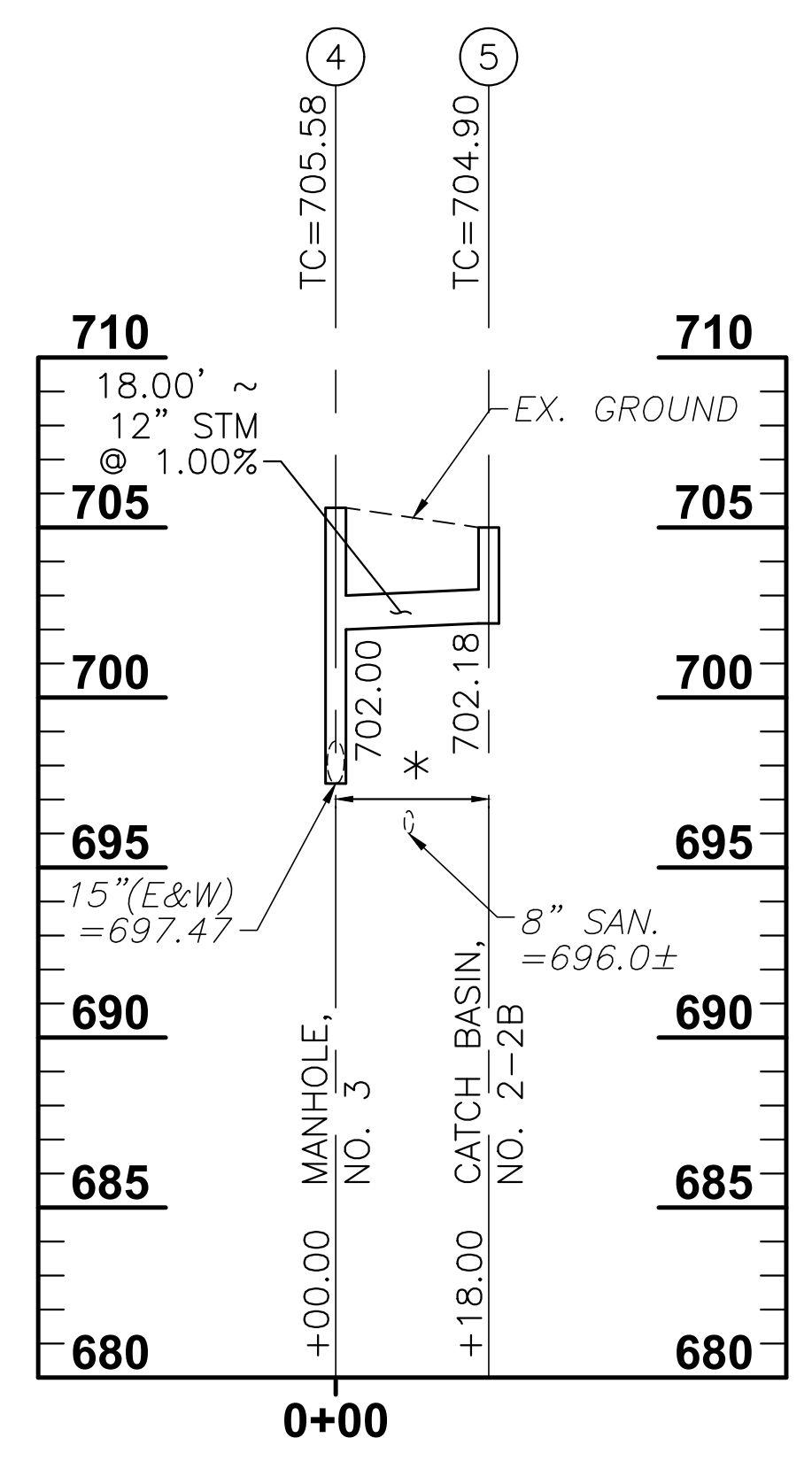
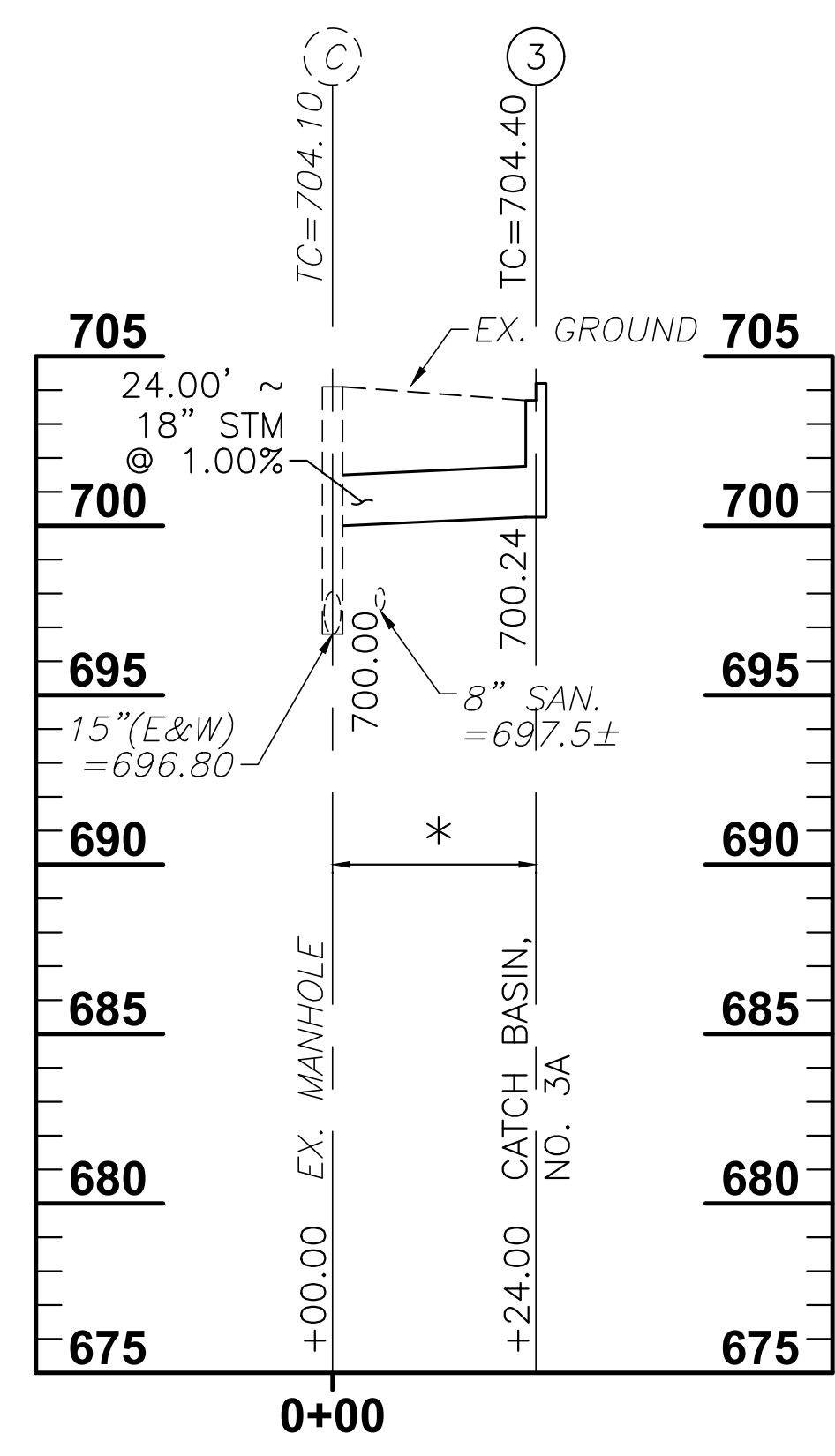
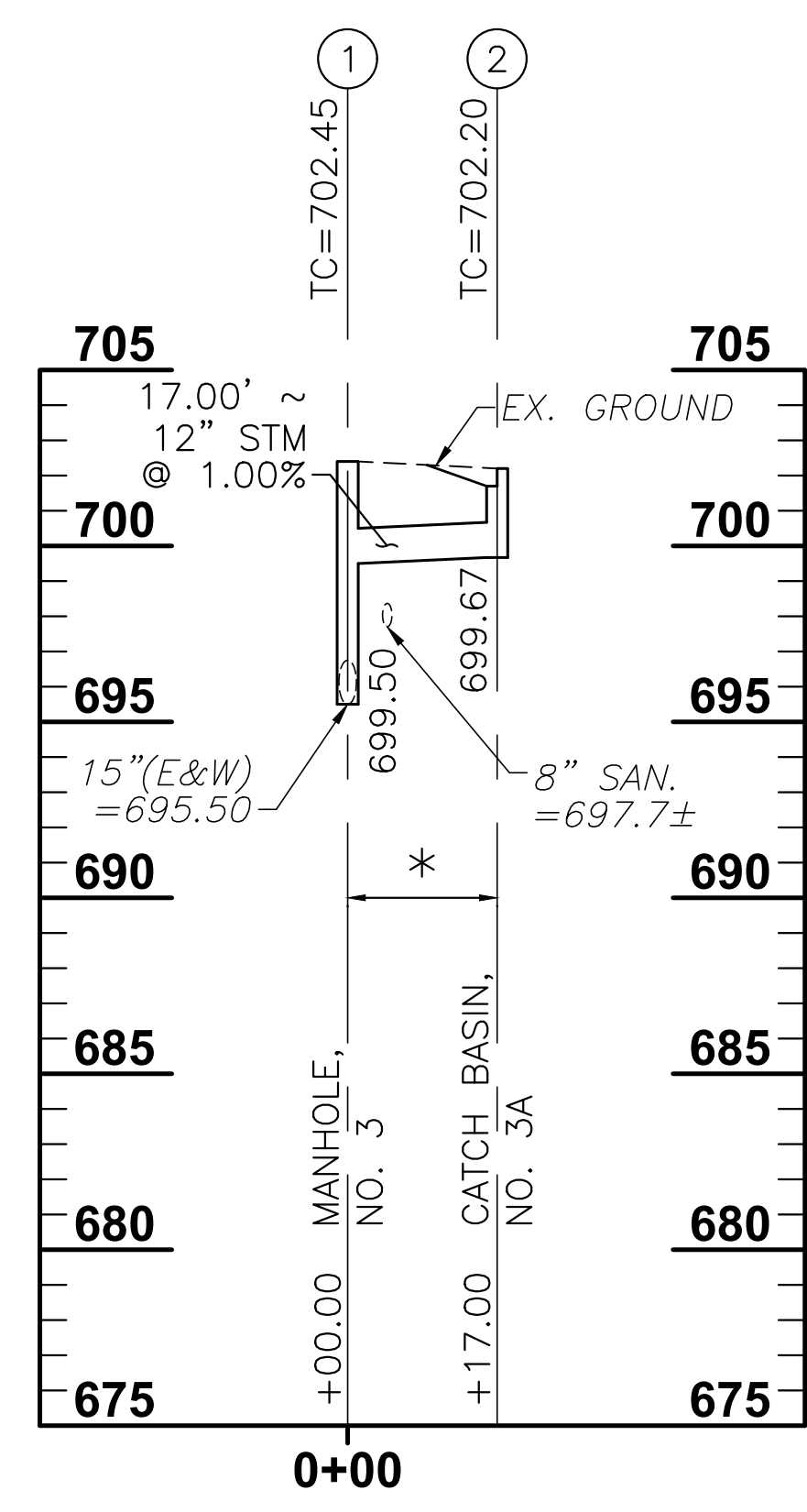

**NOTE:**  
ITEM 611, CONDUIT TYPE B, AS PER PLAN:  
ALL CONDUIT 12", 15" AND 18" SHALL BE  
TYPE B, 706.02 OR 707.33.

**NOTE:**  
MAINTAIN MINIMUM OF 10'-0" HORIZONTAL  
(OUT-TO-OUT) AND 1'-6" VERTICAL  
CLEARANCE FROM ALL WATER LINES.

SCALE: HORIZ: 1" = 20'  
VERT: 1" = 5'

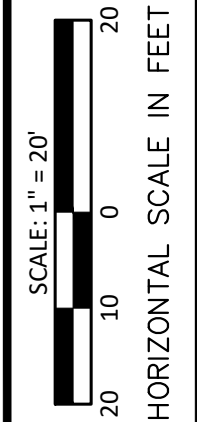
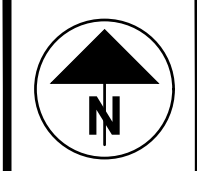

CALCULATED  
CHECKED

# STORM SEWER PROFILES

PIC-316 - 13.05-13.68  
PART 2

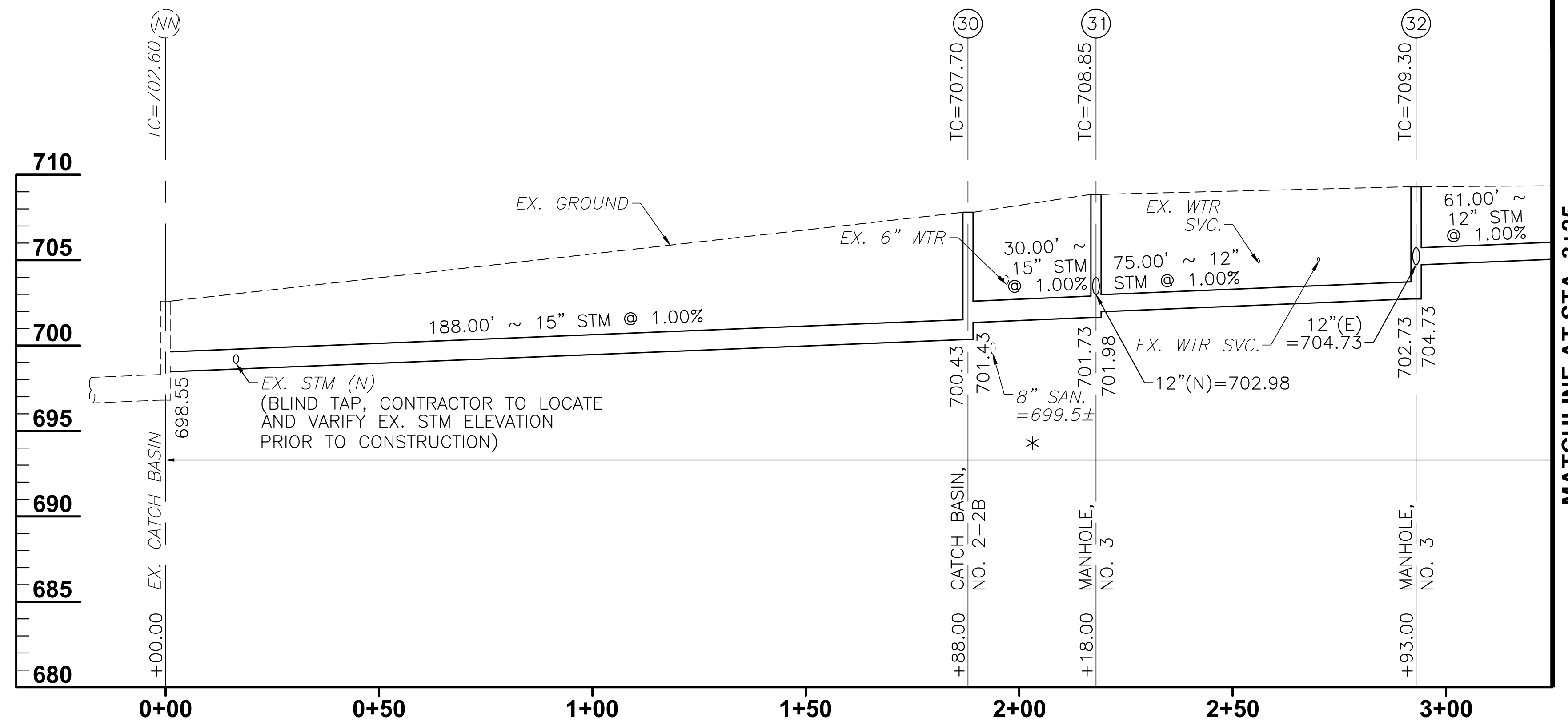
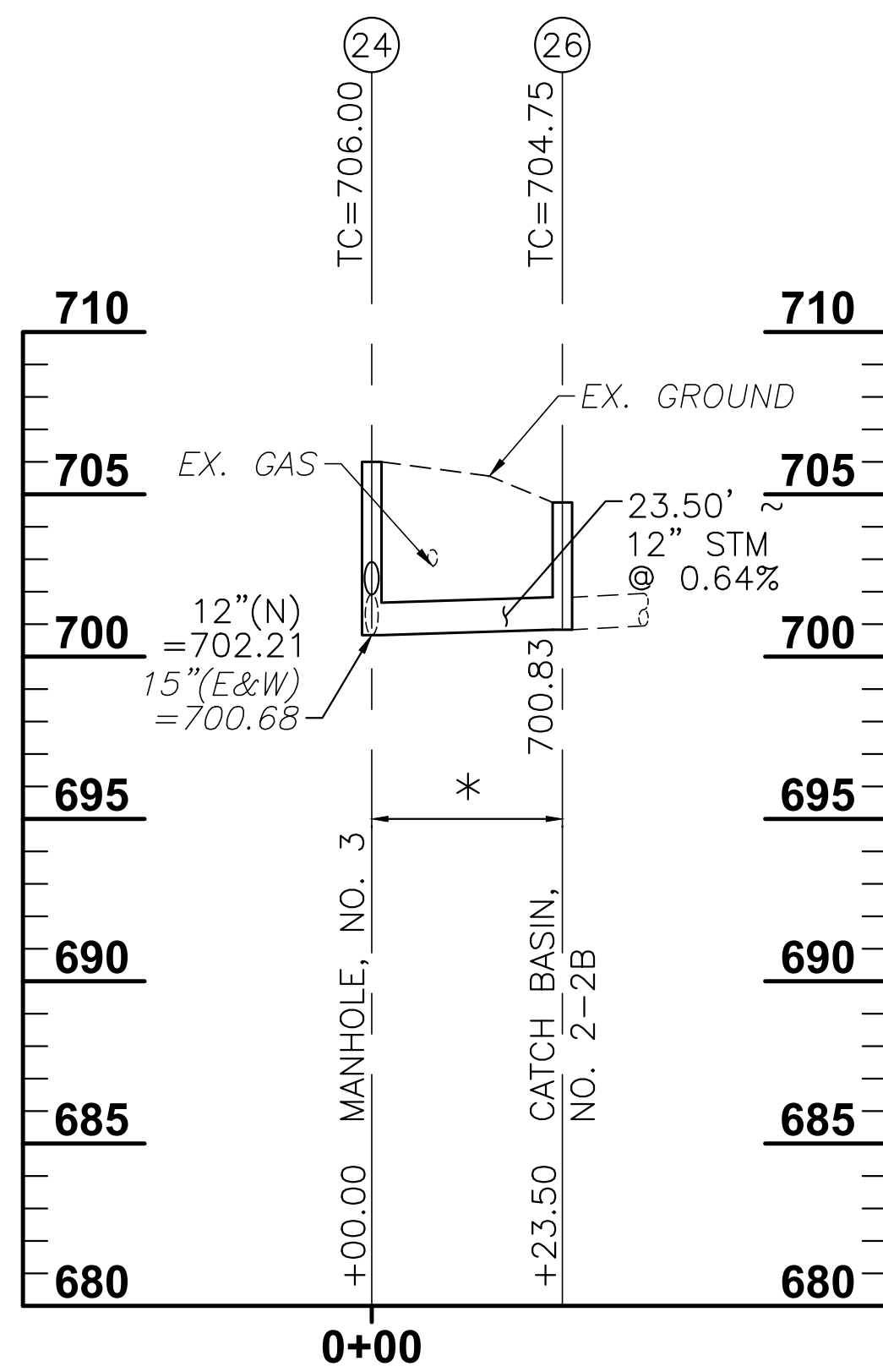
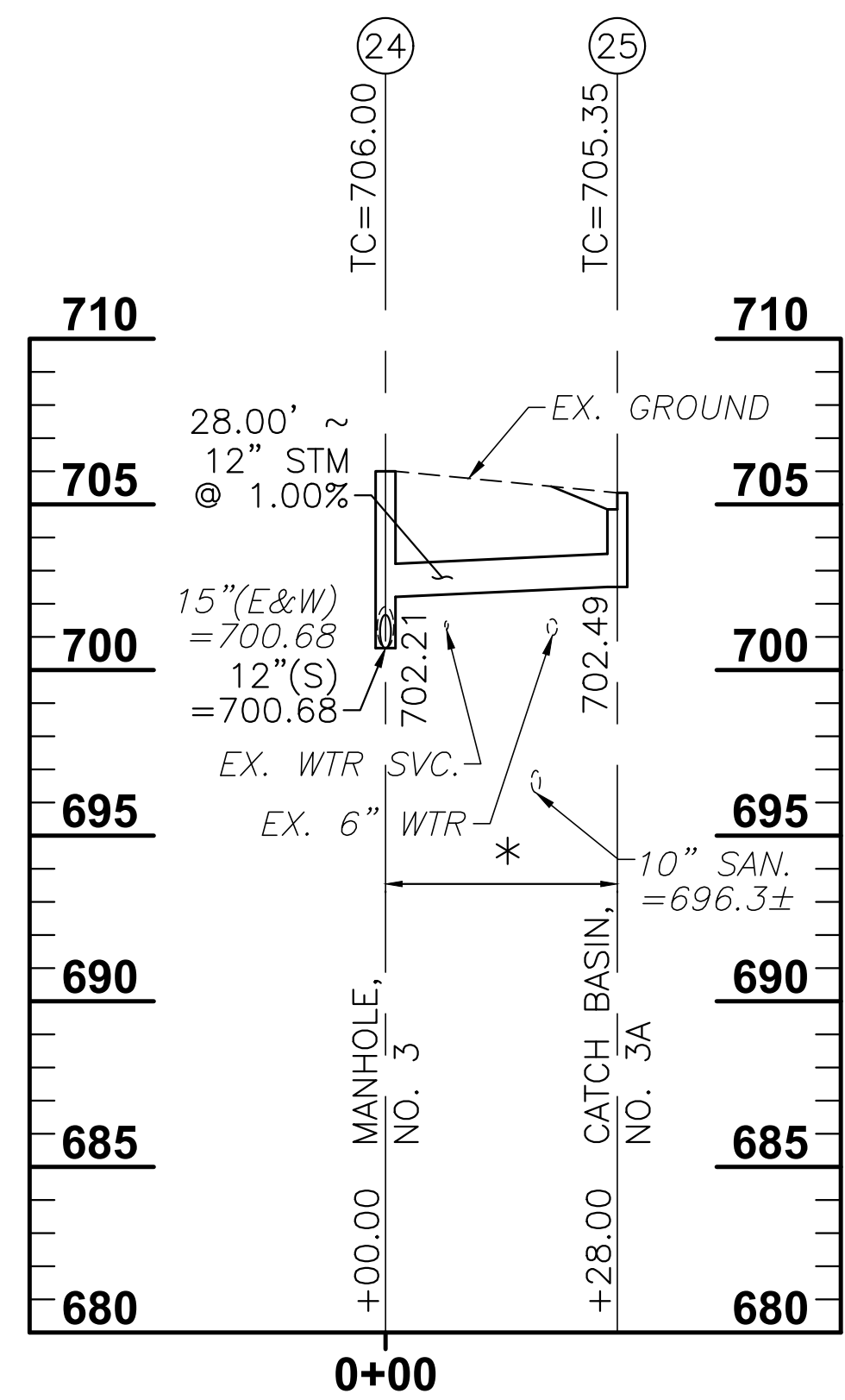
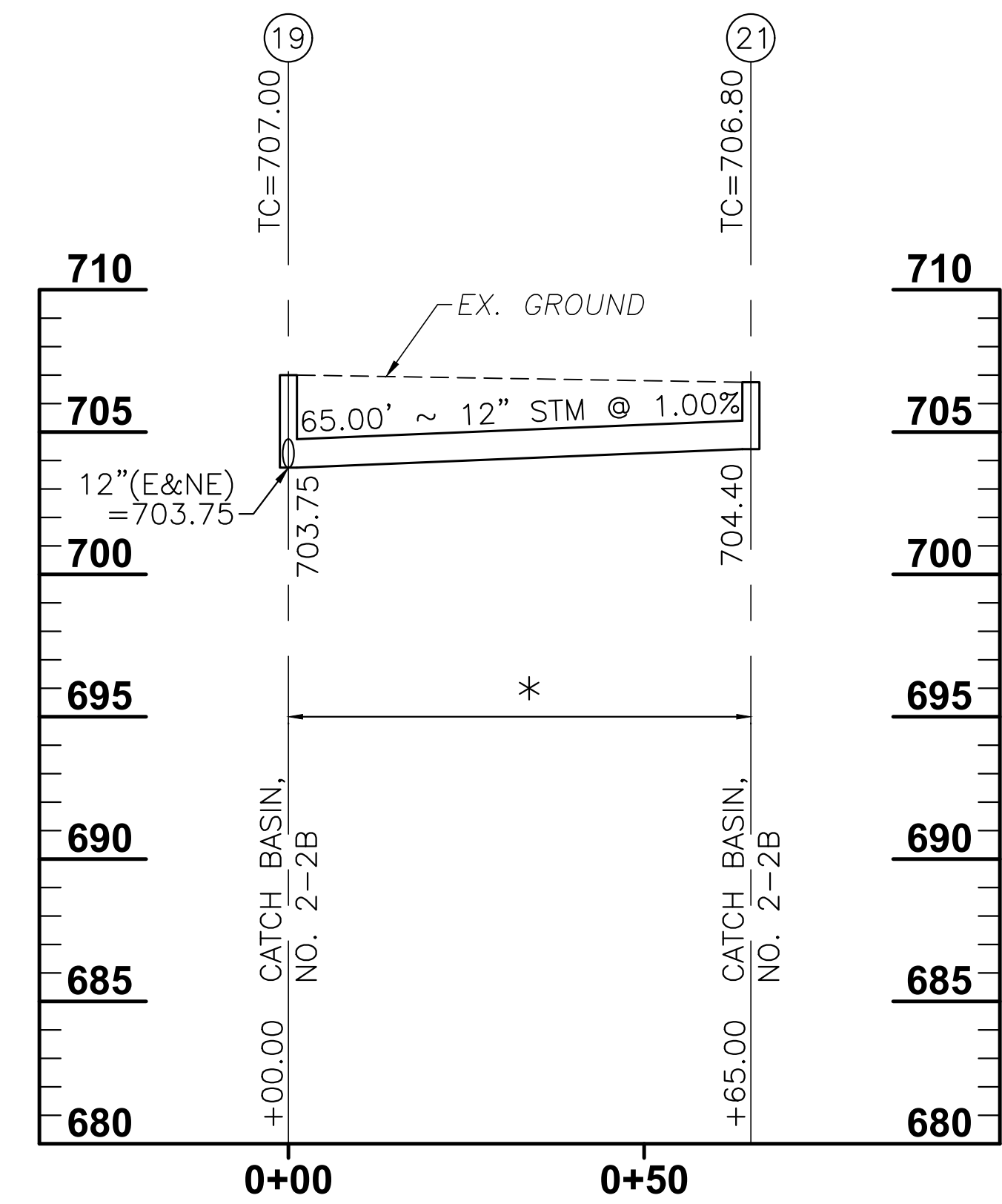
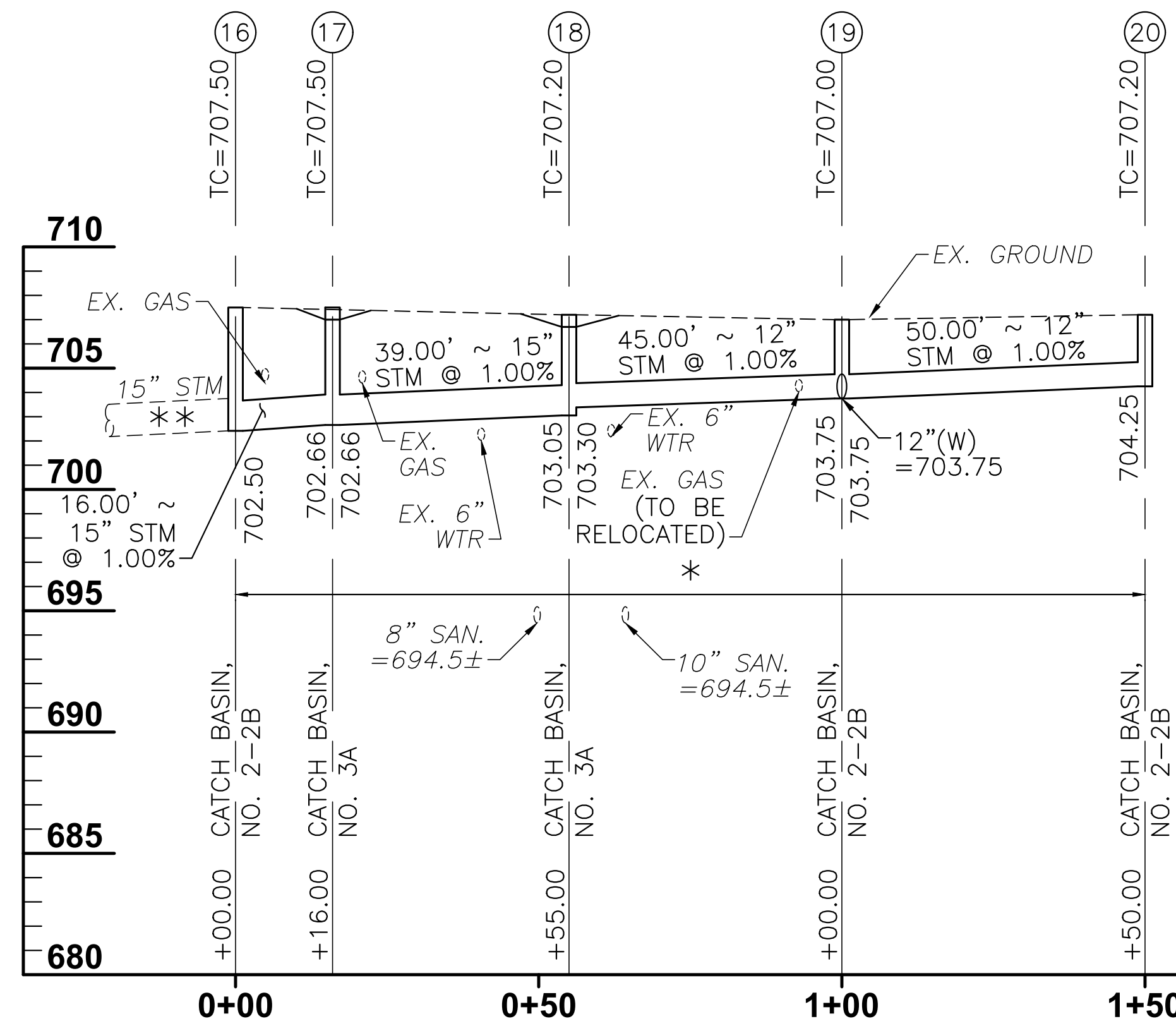
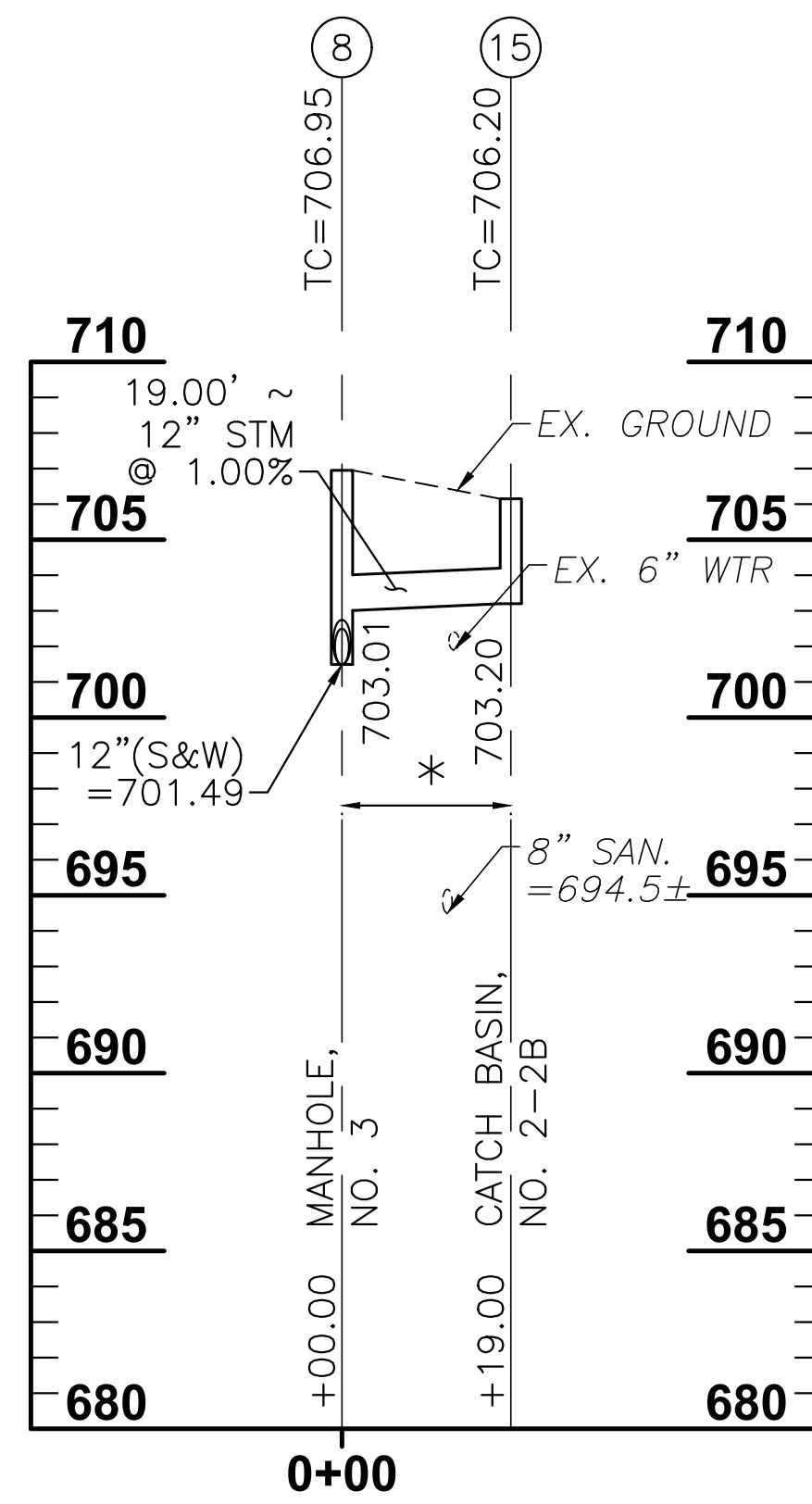

**NOTE**  
ITEM 611, CONDUIT TYPE B, AS PER PLAN:  
ALL CONDUIT 12", 15" AND 18" SHALL BE  
TYPE B, 706.02 OR 707.33.

\*\* = STORM SEWER INVERT IS UNKNOWN, CONTRACTOR TO  
FIELD VERIFY ELEVATION PRIOR TO CONSTRUCTION.

**NOTE:**  
MAINTAIN MINIMUM OF 10'-0" HORIZONTAL  
(OUT-TO-OUT) AND 1'-6" VERTICAL  
CLEARANCE FROM ALL WATER LINES.

**SCALE:** HORIZ: 1" = 20'  
VERT: 1" = 5'

MATCHLINE AT STA. 3+25

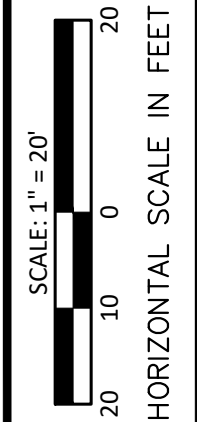
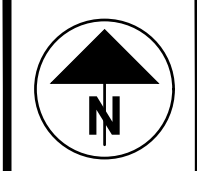

CALCULATED  
CHECKED

**STORM SEWER PROFILES**

**PIC-316 - 13.05-13.68  
PART 2**

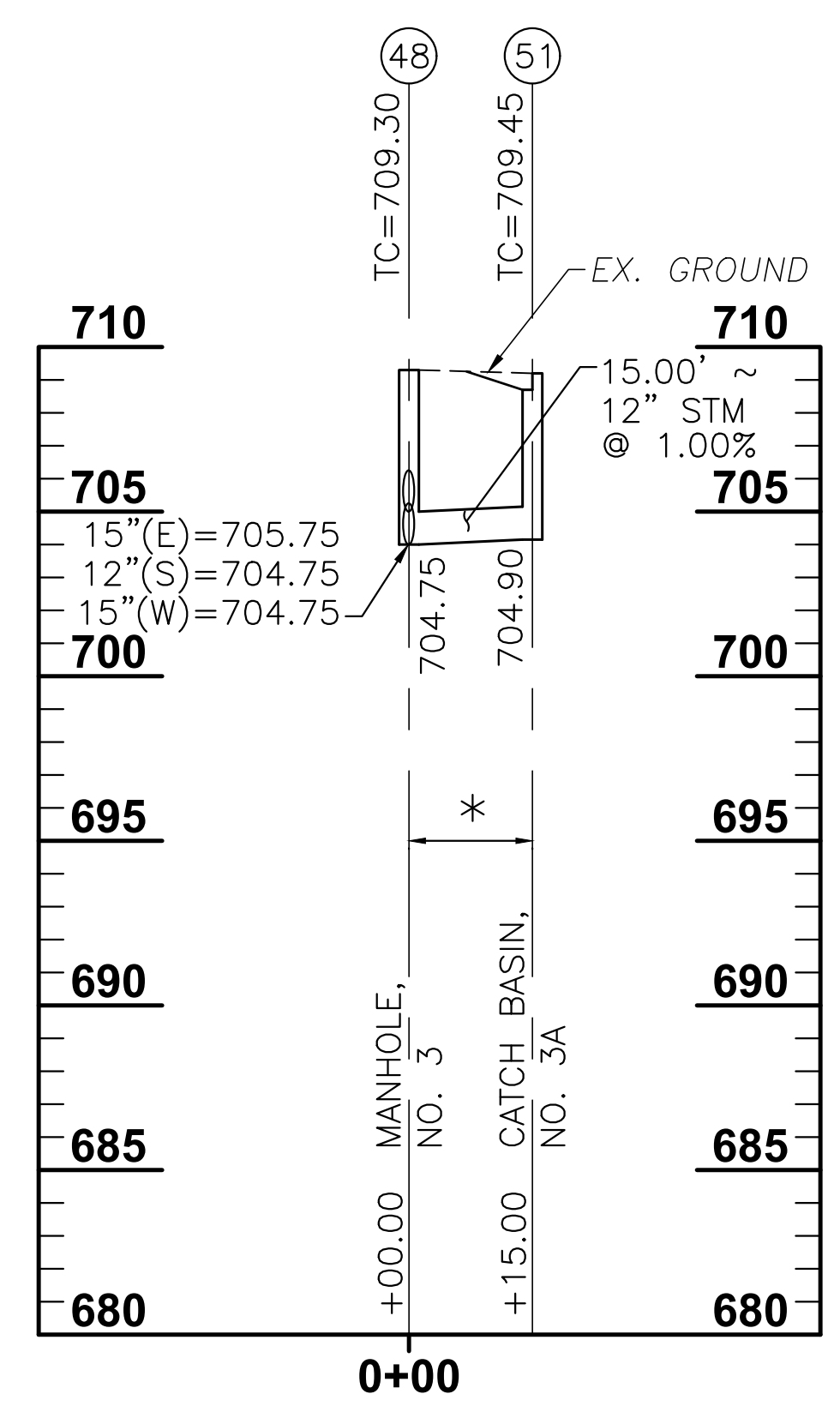
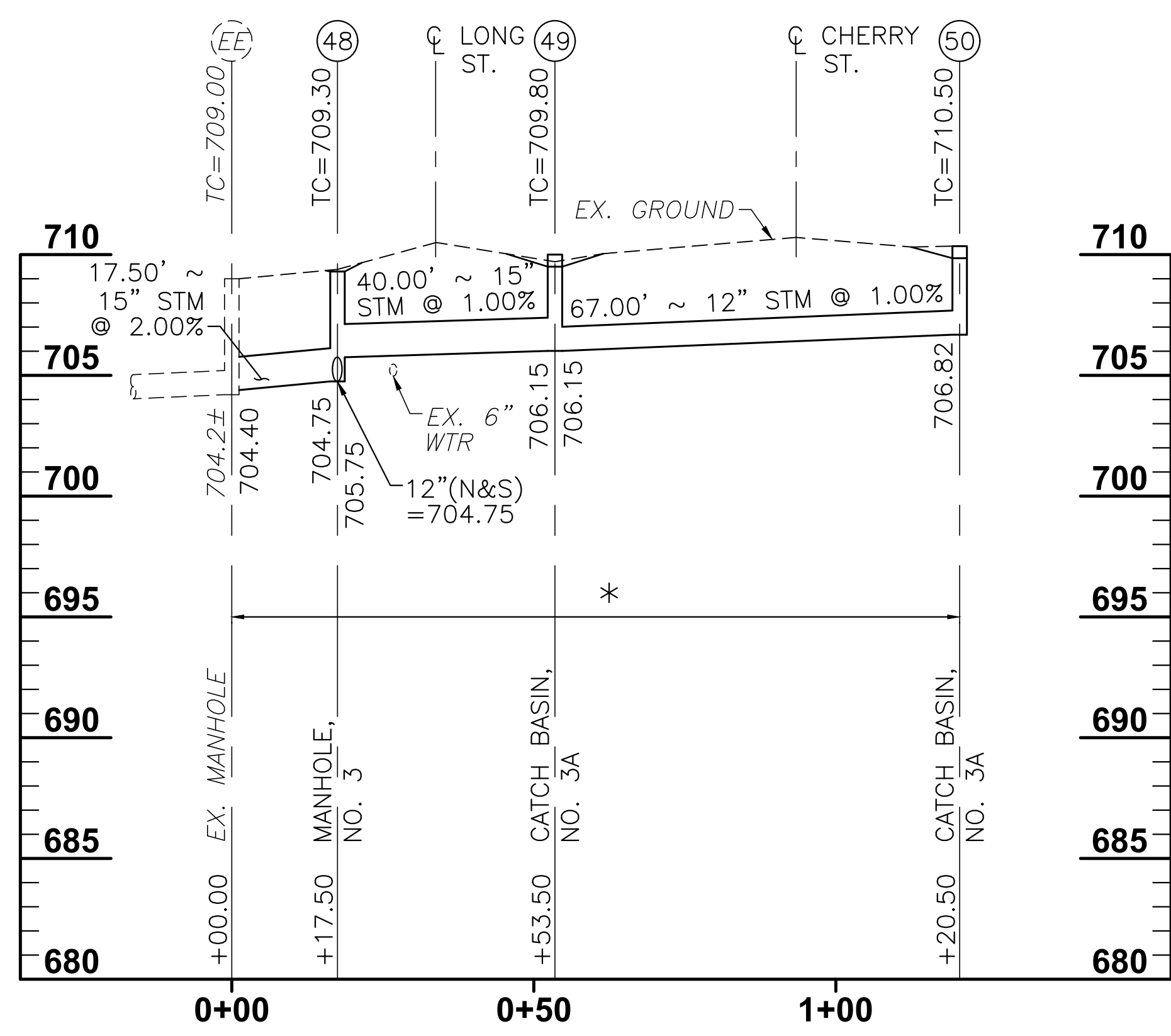
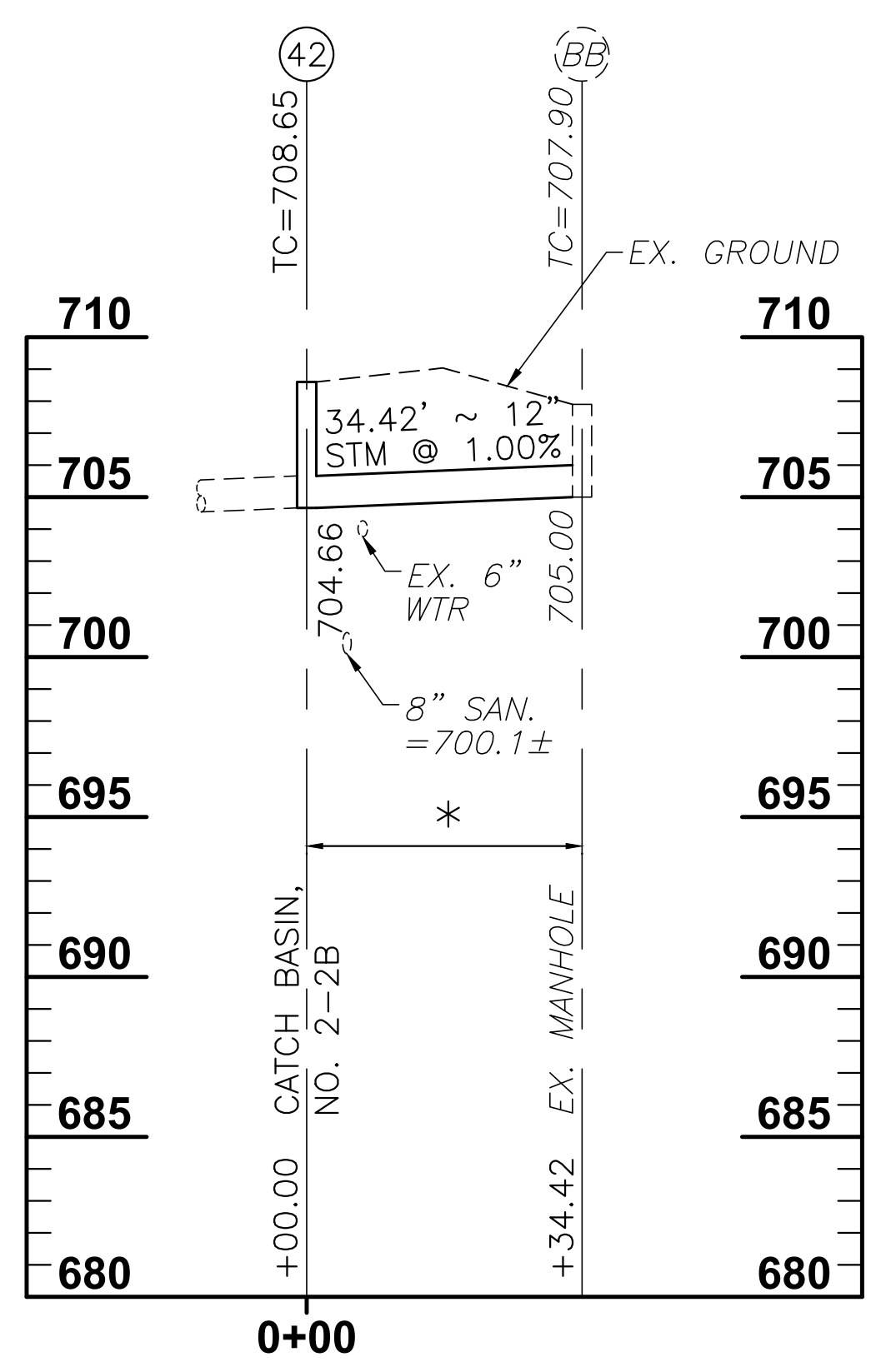
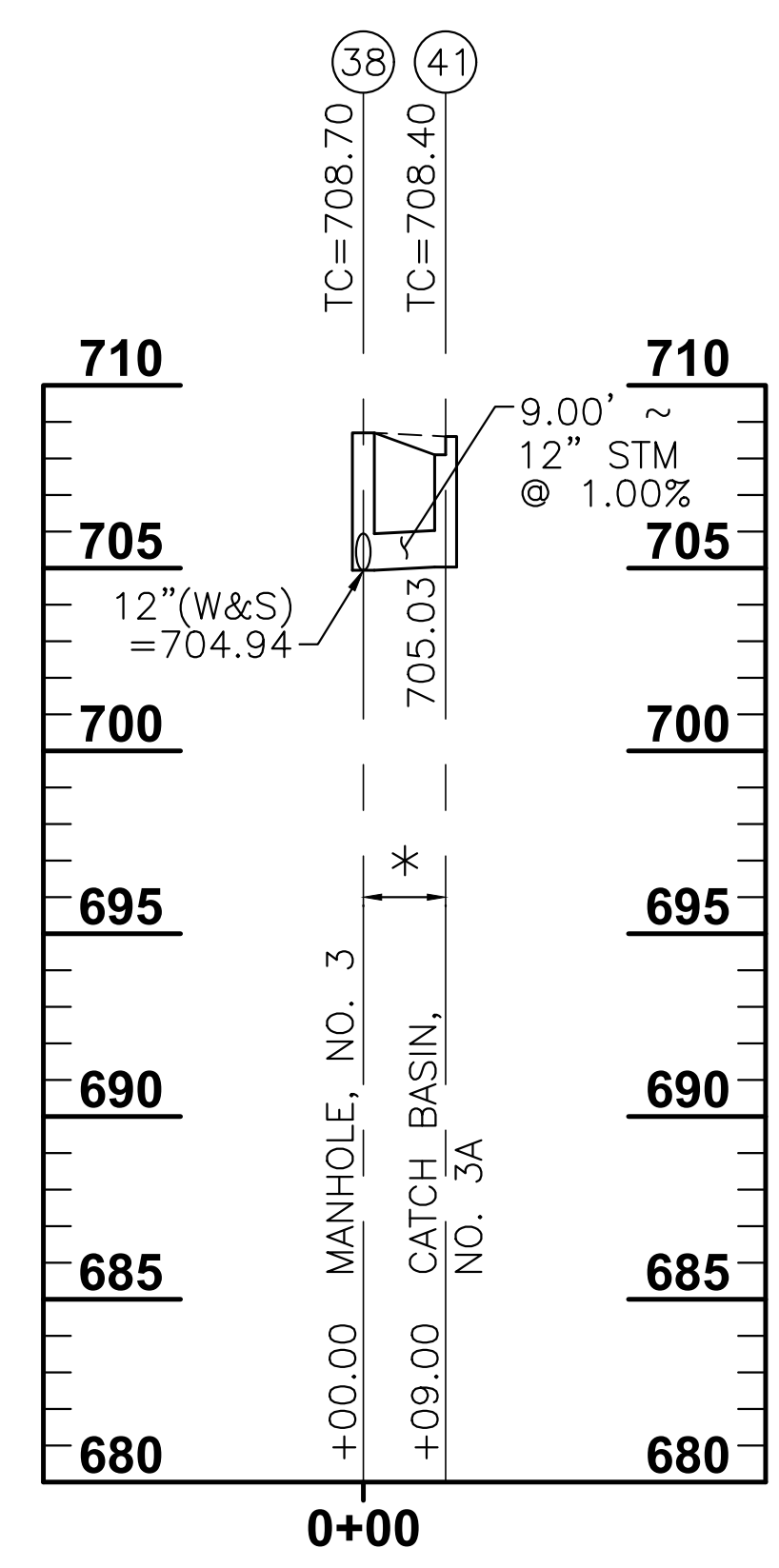
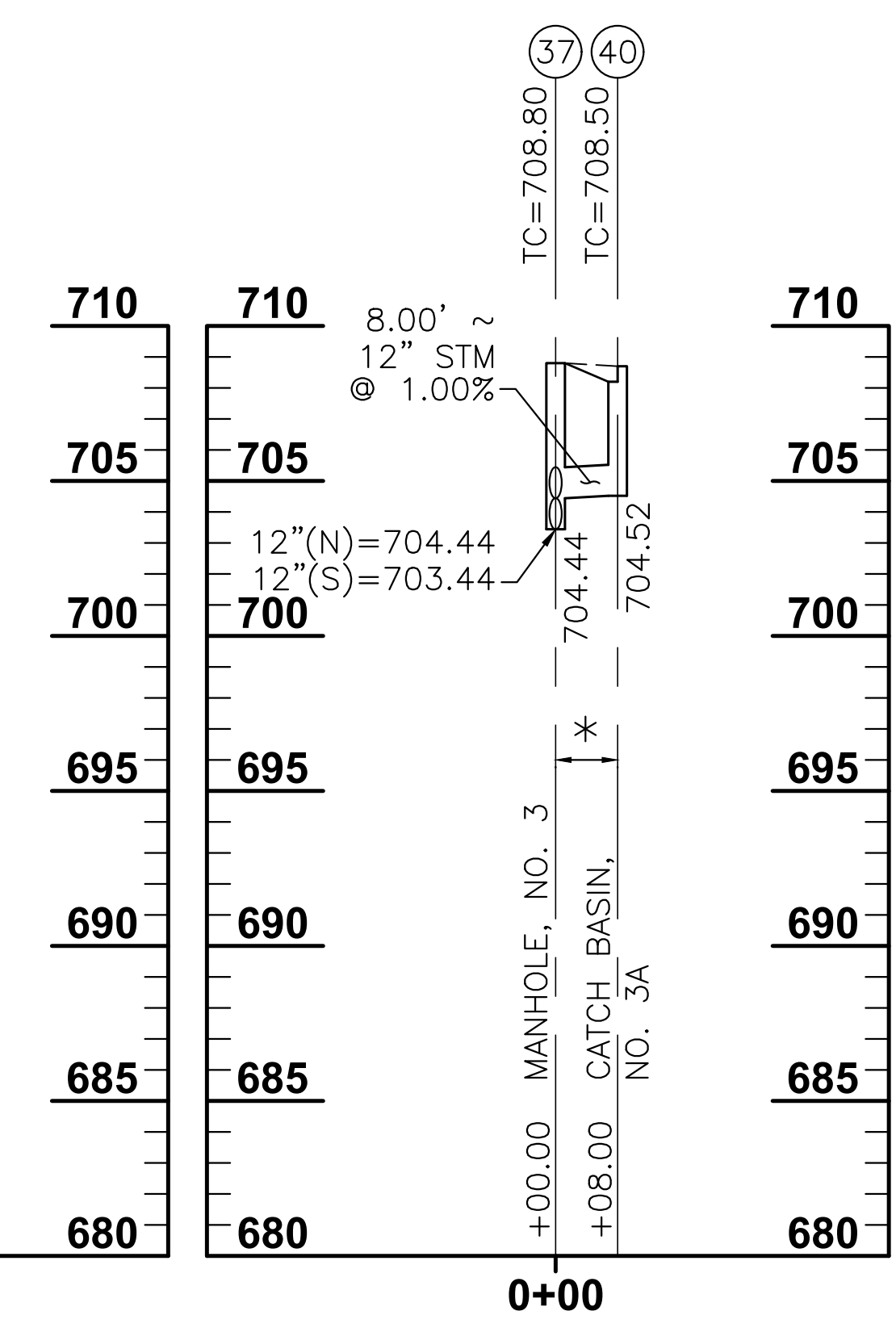
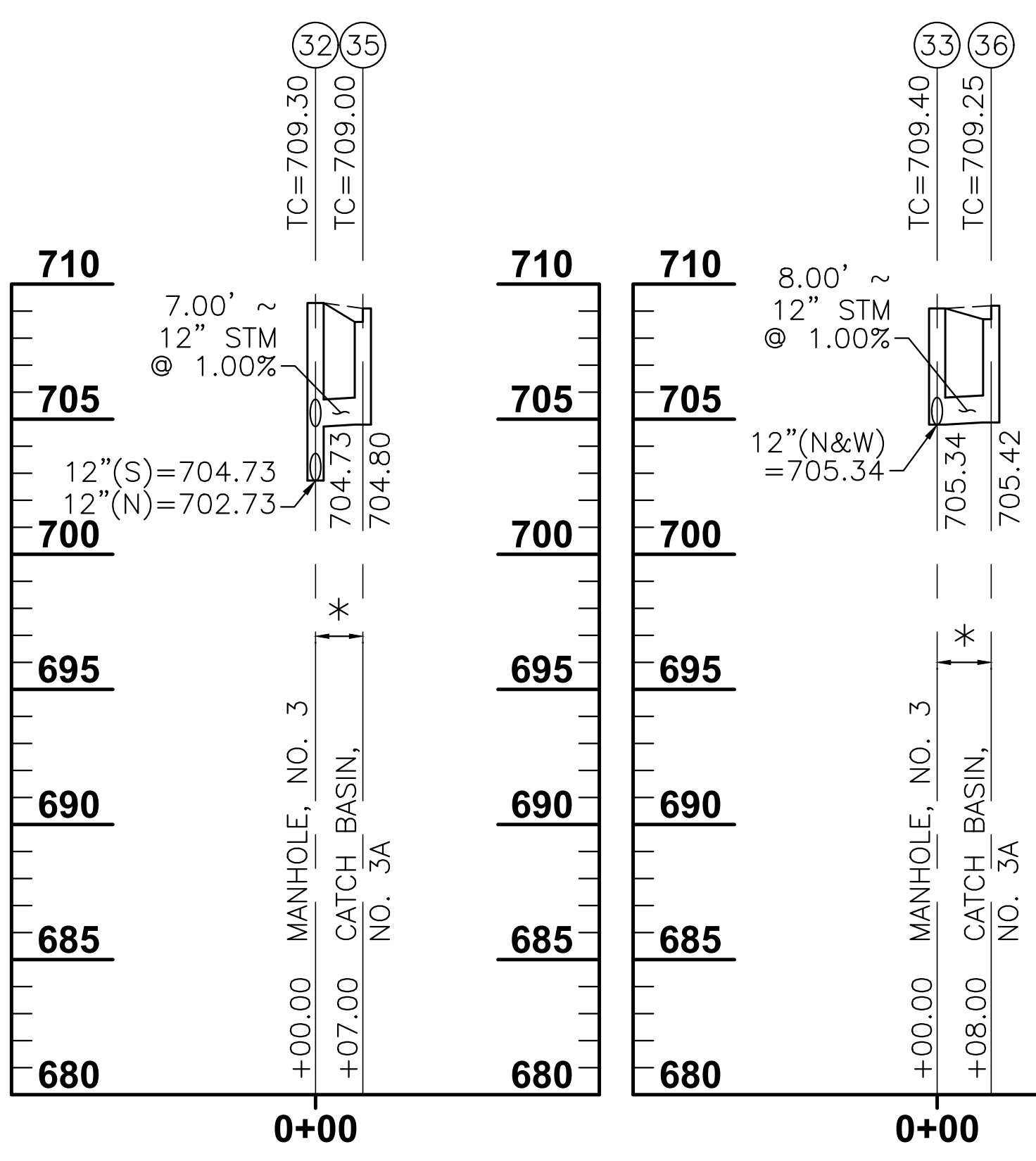
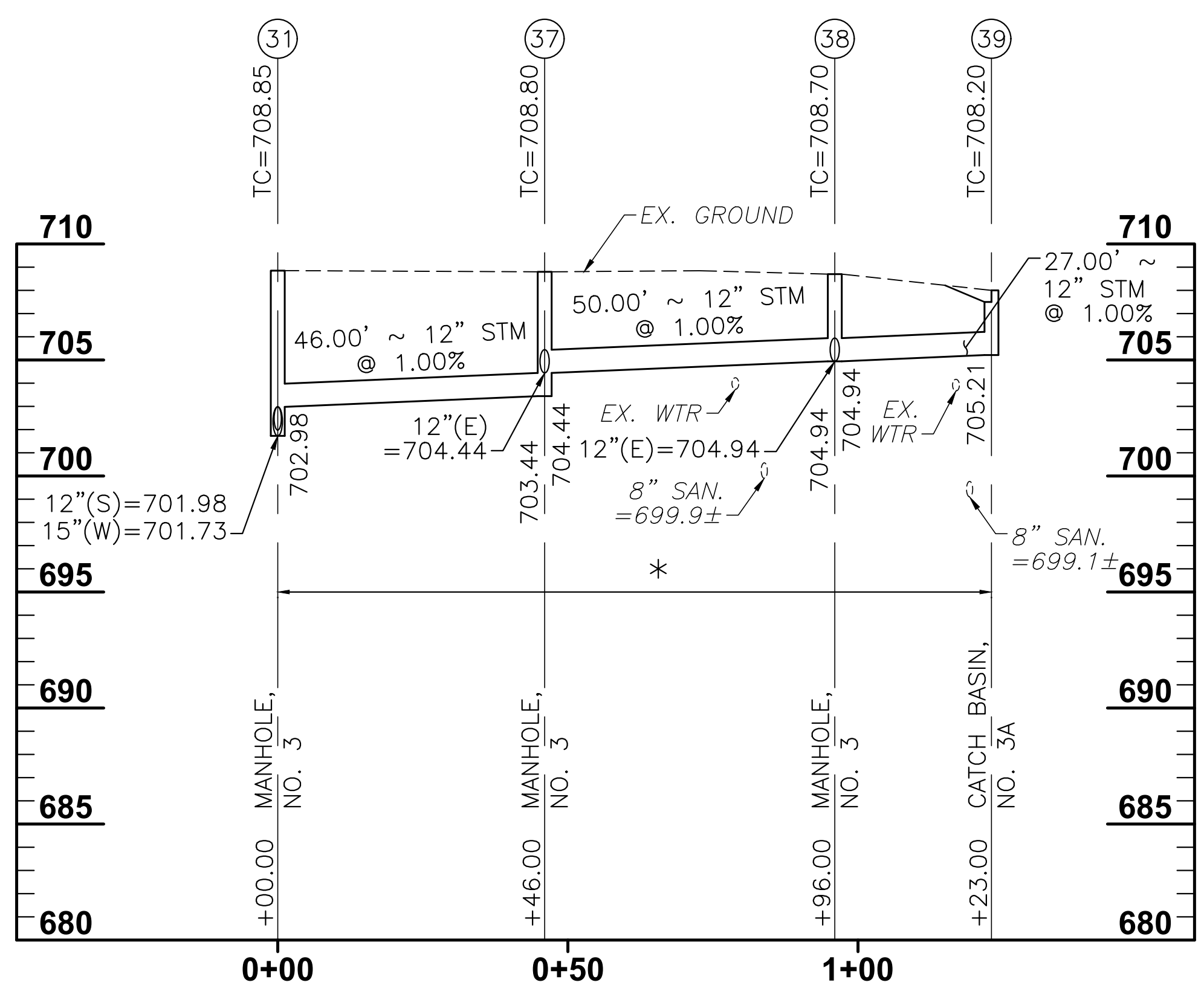
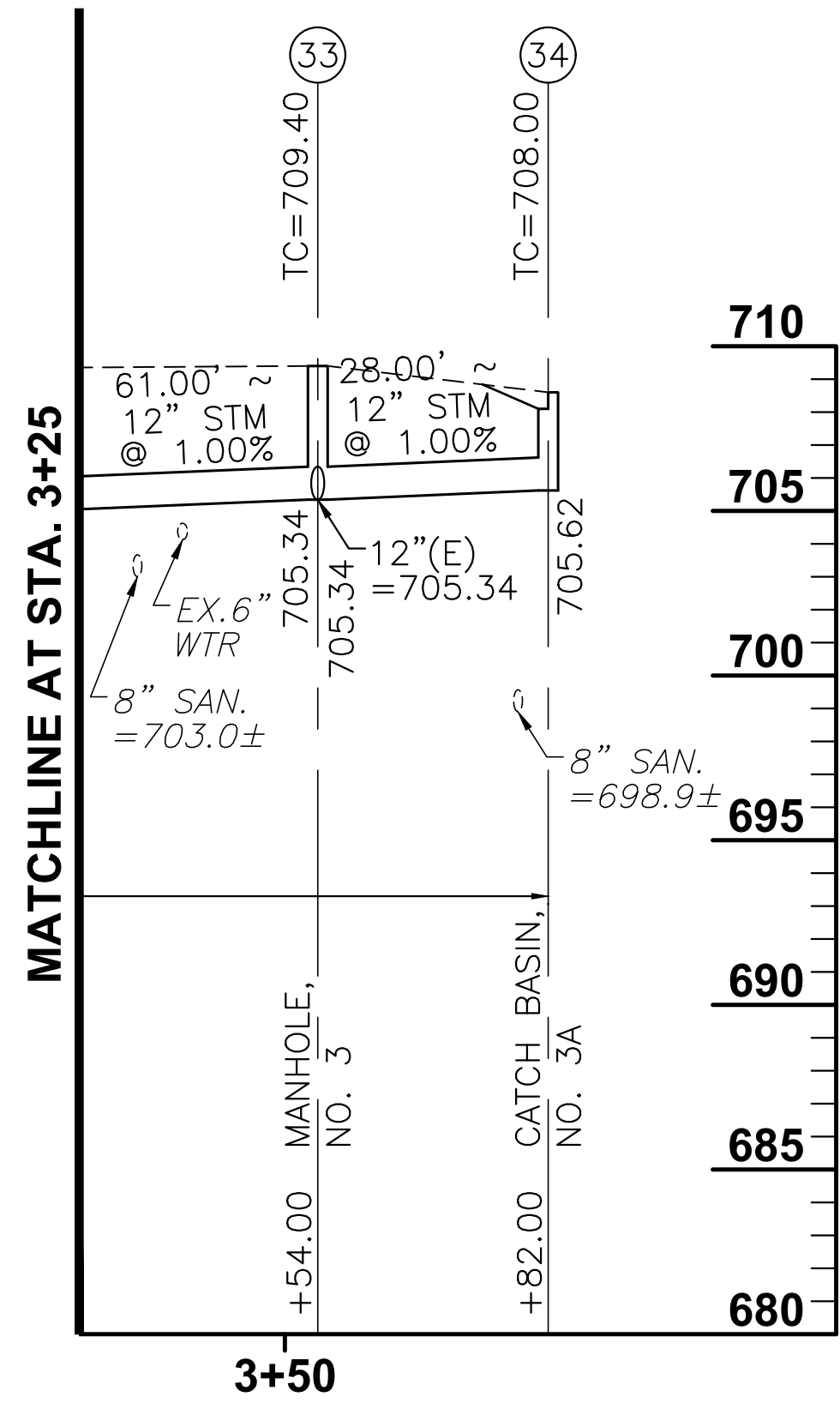

**NOTE:**  
ITEM 611, CONDUIT TYPE B, AS PER PLAN:  
ALL CONDUIT 12", 15" AND 18" SHALL BE  
TYPE B, 706.02 OR 707.33.

**NOTE:**  
MAINTAIN MINIMUM OF 10'-0" HORIZONTAL  
(OUT-TO-OUT) AND 1'-6" VERTICAL  
CLEARANCE FROM ALL WATER LINES.

**SCALE:** HORIZ: 1" = 20'  
VERT: 1" = 5'

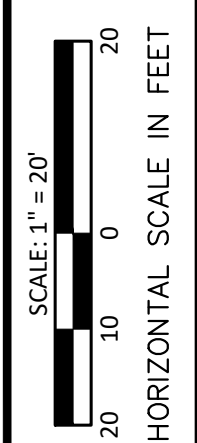
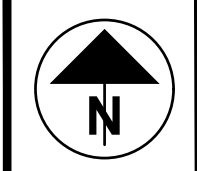

CALCULATED  
CHECKED

# STORM SEWER PROFILES

PIC-316 - 13.05-13.68  
PART 2

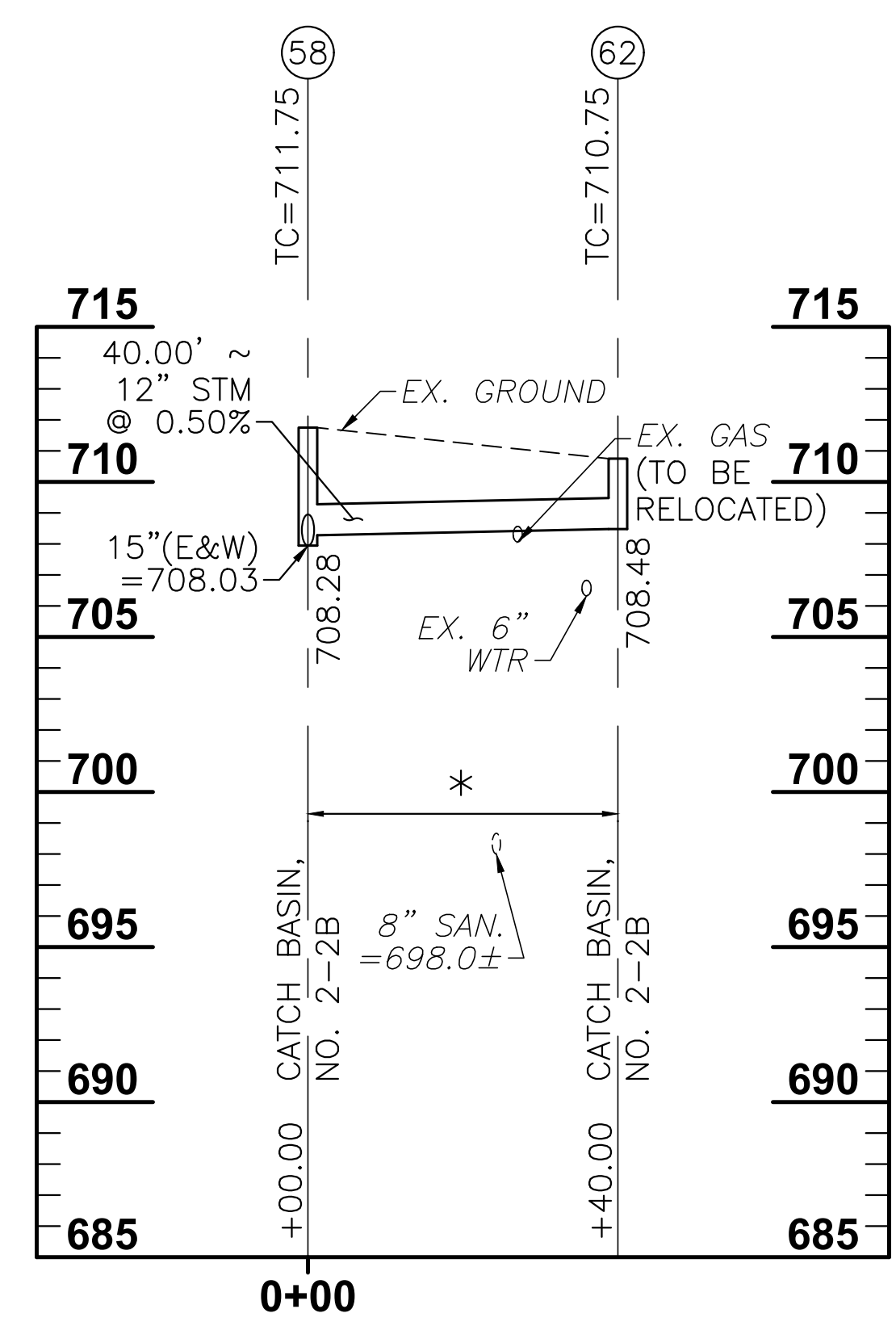
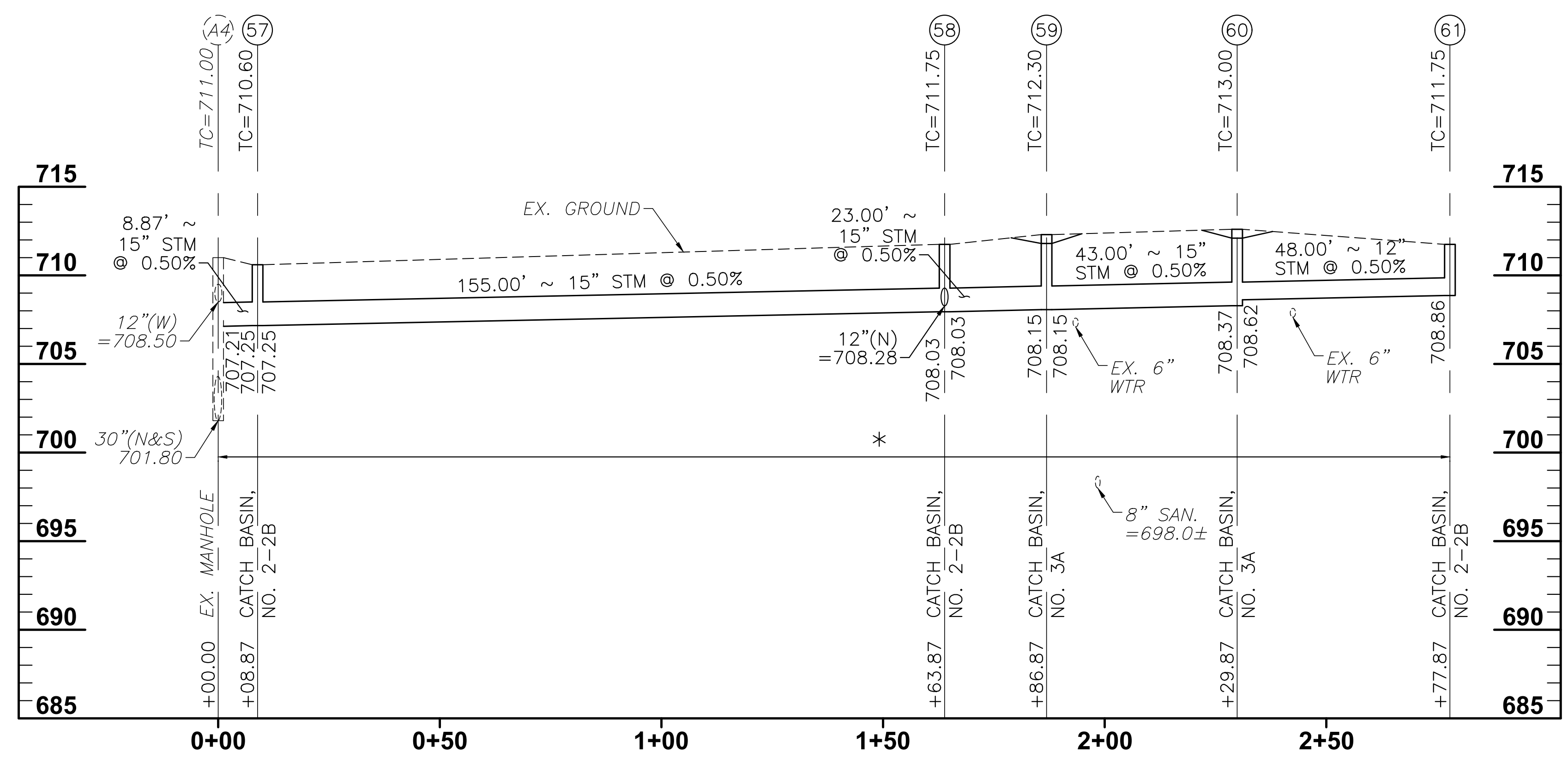
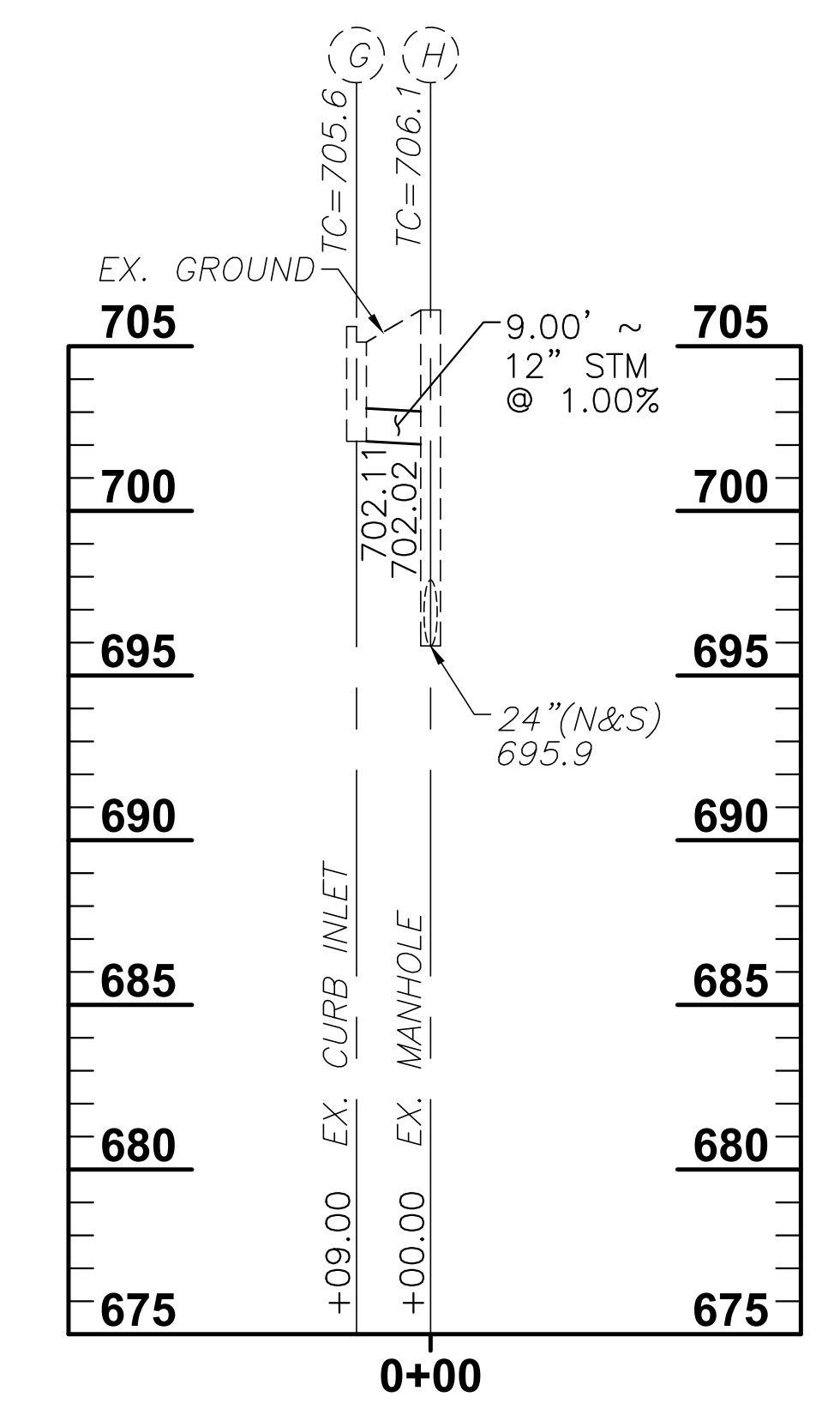
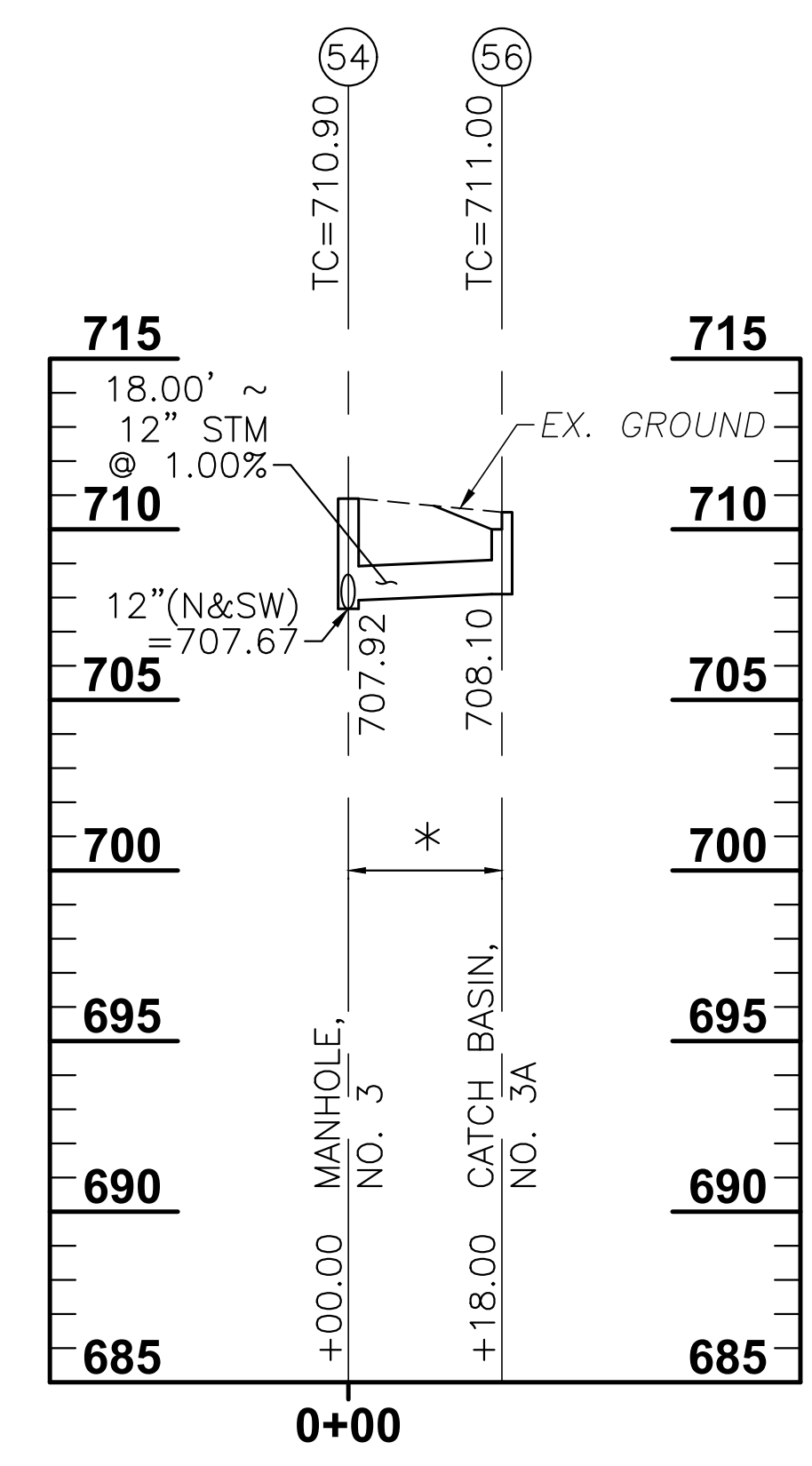
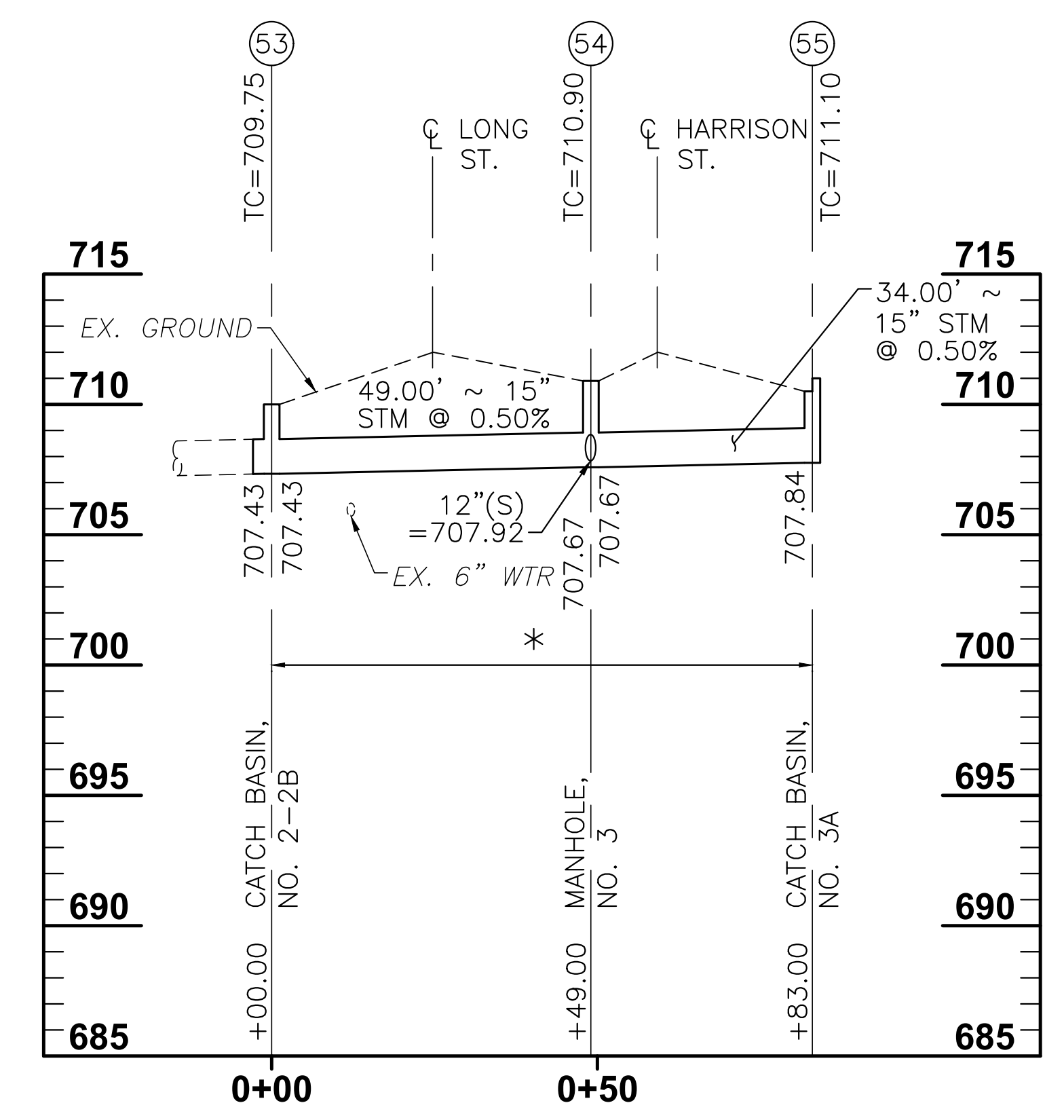
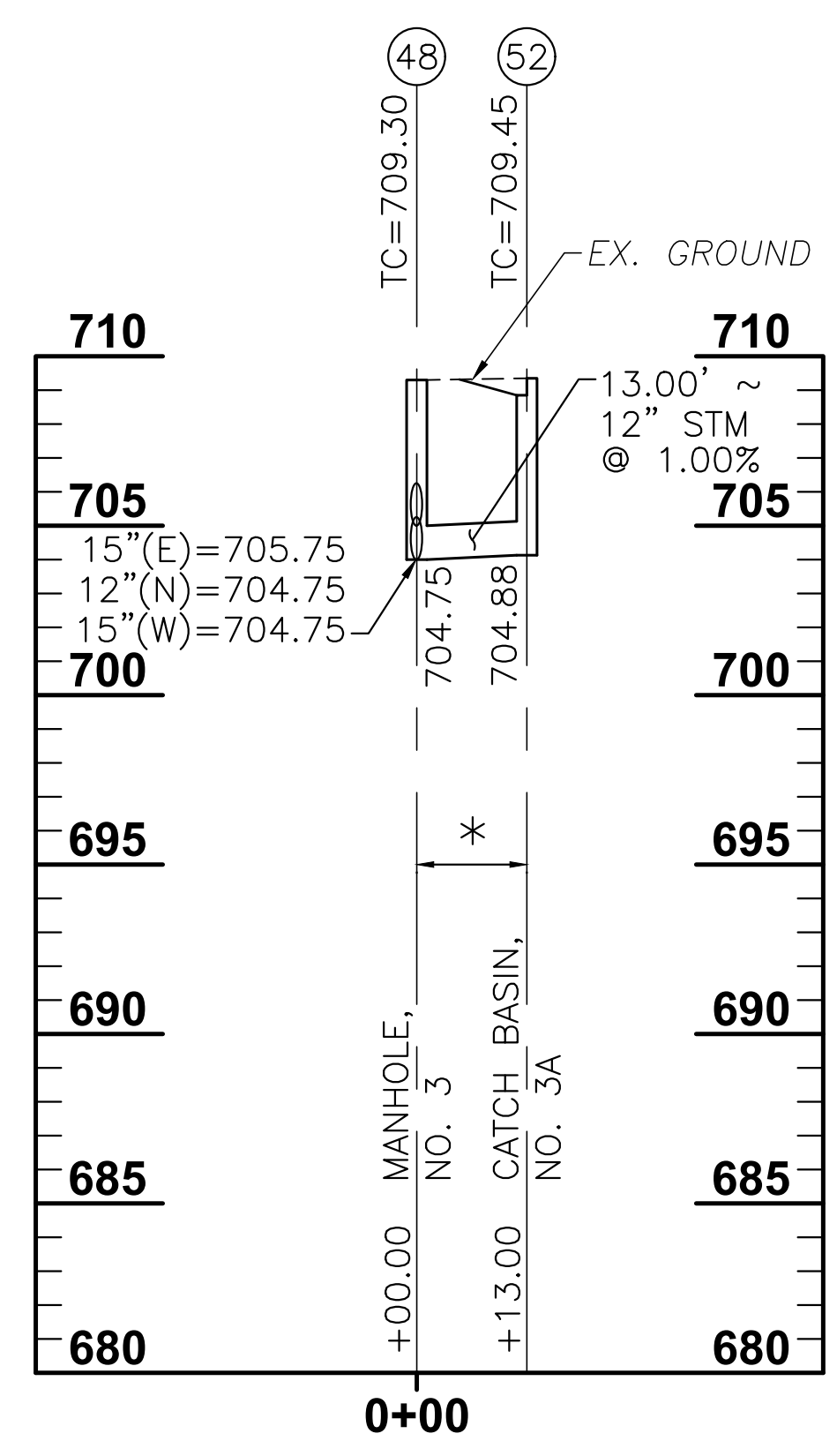

NOTE:  
ITEM 611, CONDUIT TYPE B, AS PER PLAN:  
ALL CONDUIT 12", 15" AND 18" SHALL BE  
TYPE B, 706.02 OR 707.33.

NOTE:  
MAINTAIN MINIMUM OF 10'-0" HORIZONTAL  
(OUT-TO-OUT) AND 1'-6" VERTICAL  
CLEARANCE FROM ALL WATER LINES.

SCALE: HORIZ: 1" = 20'  
VERT: 1" = 5'