

# STATE OF OHIO DEPARTMENT OF TRANSPORTATION

## PRE-121-0.98/2.07

VILLAGE OF NEW PARIS  
JEFFERSON TOWNSHIP  
PREBLE COUNTY

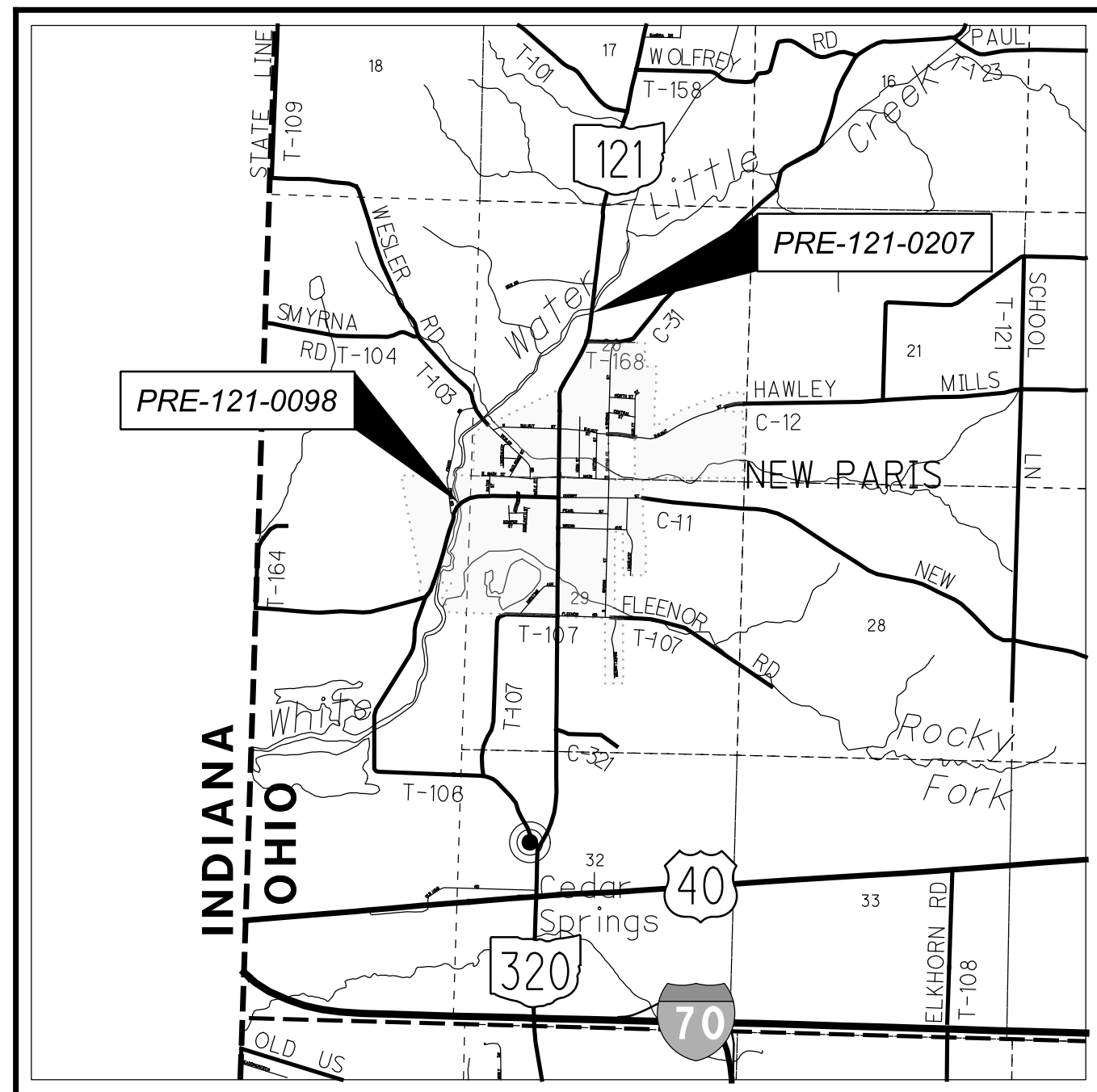

**LOCATION MAP**

LATITUDE: N39°51'39" LONGITUDE: W84°47'43"

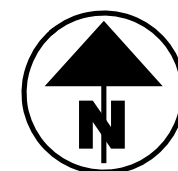

PORTION TO BE IMPROVED	—————	=====
INTERSTATE HIGHWAY	—————	=====
FEDERAL ROUTES	—————	=====
STATE ROUTES	—————	=====
COUNTY & TOWNSHIP ROADS	—————	=====
OTHER ROADS	—————	=====

**DESIGN DESIGNATION**

	PRE-121-0098	PRE-121-0207
CURRENT ADT (2023)	2,200	1,900
DESIGN YEAR ADT (2043)	2,700	2,000
DESIGN HOURLY VOLUME (2043)	270	200
DIRECTIONAL DISTRIBUTION	0.65	0.70
TRUCKS (24 HOUR B&C)	2.0%	5.0%
DESIGN SPEED	50 MPH	55 MPH
LEGAL SPEED	50 MPH	55 MPH
DESIGN FUNCTIONAL CLASSIFICATION:		
06 MINOR COLLECTOR		
NHS PROJECT	NO	

**DESIGN EXCEPTIONS**

NONE

**ADA DESIGN WAIVERS**

NONE

**UNDERGROUND UTILITIES**  
Contact Two Working Days  
Before You Dig

**OHIO811.org**  
Before You Dig

OHIO 811, 8-1-1, or 1-800-362-2764  
(Non members must be called directly)

PLAN PREPARED BY:  
OHIO DEPARTMENT OF TRANSPORTATION  
DISTRICT 8 ENGINEERING  
505 SOUTH S.R. 741 LEBANON, OHIO 45036

**INDEX OF SHEETS:**

TITLE SHEET	1
TYPICAL SECTIONS	2
GENERAL NOTES	3
MAINTENANCE OF TRAFFIC	4 - 8
GENERAL SUMMARY	9
ROADWAY SUBSUMMARIES	10
PLAN INSERT SHEETS	11 - 16
CROSS SECTIONS	17 - 22
STRUCTURES OVER 20 FOOT SPAN	
PRE-121-0098	23 - 34
PRE-121-0207	35 - 49
HISTORIC BORING LOGS	50 - 53

**FEDERAL PROJECT NUMBER**

E161 (443)

**RAILROAD INVOLVEMENT**

NONE

**PROJECT DESCRIPTION**

IMPROVEMENT OF TWO STRUCTURES CARRYING S.R. 121. REHABILITATION OF A BRIDGE CARRYING S.R. 121 OVER EAST FORK OF WHITEWATER RIVER BY CONSTRUCTING CONCRETE OVERLAY, REPLACEMENT OF APPROACH GUARDRAIL AS WELL AS OTHER BRIDGE MAINTENANCE ITEMS. REPLACEMENT OF THE EXISTING SUPERSTRUCTURE OF A BRIDGE CARRYING S.R. 121 OVER EAST FORK OF WHITEWATER RIVER WITH REINFORCED CONCRETE SLAB SUPERSTRUCTURE AND REPLACEMENT OF APPROACH GUARDRAIL.

**EARTH DISTURBED AREAS**

PRE-127-0098	
PROJECT EARTH DISTURBED AREA:	0.38 ACRES
ESTIMATED CONTRACTOR EARTH DISTURBED AREA:	0.25 ACRES
PRE-127-0207	
PROJECT EARTH DISTURBED AREA:	0.69 ACRES
ESTIMATED CONTRACTOR EARTH DISTURBED AREA:	0.25 ACRES

NOTICE OF INTENT EARTH DISTURBED AREA: N/A (NOI NOT REQUIRED)

**2023 SPECIFICATIONS**

THE STANDARD SPECIFICATIONS OF THE STATE OF OHIO, DEPARTMENT OF TRANSPORTATION, INCLUDING SUPPLEMENTAL SPECIFICATIONS LISTED IN THE PLANS AND CHANGES LISTED IN THE PROPOSAL SHALL GOVERN THIS IMPROVEMENT.

I HEREBY APPROVE THESE PLANS AND DECLARE THAT THE MAKING OF THIS IMPROVEMENT WILL REQUIRE THE CLOSING TO TRAFFIC OF THE HIGHWAY AND THAT DETOURS WILL BE PROVIDED AS INDICATED ON SHEET 5.

*Tammy K. Campbell*  
\_\_\_\_\_  
Tammy K. Campbell, P.E.  
District 08 Deputy Director

*Jack Marchbanks*  
\_\_\_\_\_  
Jack Marchbanks, PhD  
Director, Department of Transportation

STANDARD CONSTRUCTION DRAWINGS								SUPPLEMENTAL SPECIFICATIONS		SPECIAL PROVISIONS	
BP-3.1	1/21/22	AS-1-15	1/20/23	MT-96.11	4/16/21	TC-41.20	10/18/13	800-2023	4/21/23	ASBESTOS INSPECTION SPECIAL PROVISIONS 6/23/2023	
BP-4.1	7/19/13	AS-2-15	1/20/23	MT-96.20	7/15/16	TC-41.30	10/18/13	832	7/15/22		
		CPA-1-08	7/18/08	MT-96.26	1/18/19	TC-52.20	1/15/21	846	4/17/15		
DM-1.1	7/17/20	CPP-1-08	7/21/17	MT-97.10	4/19/19	TC-61.30	7/19/19	848	1/15/21	WATERWAY PERMITS CONDITIONS SPECIAL PROVISIONS 7/28/2023	
DM-1.2	7/16/21	CS-1-08	1/15/21	MT-101.60	1/17/20	TC-65.10	1/17/14				
DM-4.4	1/15/16	DBR-3-11	7/15/11	MT-101.75	1/17/20	TC-65.11	7/15/22				
		DS-1-92	7/15/22	MT-105.10	1/17/20						
MGS-1.1	7/16/21	EXJ-4-87	1/20/23								
MGS-2.1	1/19/18	GSD-1-19	1/15/21								
MGS-3.3	7/16/21	PCB-91	7/17/20								
MGS-4.2	7/19/13	TST-2-21	7/16/21								
MGS-4.3	1/18/13										
MGS-5.3	7/15/16										
MGS-6.1	1/19/18										
RM-4.2	4/17/20										

ENGINEER'S SEAL

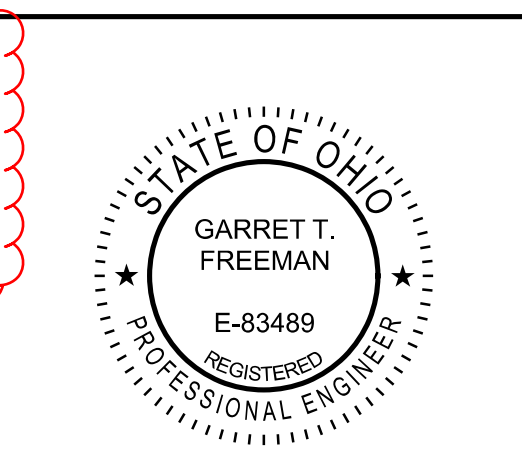

PRE-121-0098/0207

MODEL: Sheet PAPER: 34x22 (in.) DATE: 8/14/2023 TIME: 10:16:45 AM USER: gfreeman p:\vohodoc-pw-bentley.com\ohiodot-pw-02\Documents\01 Active Projects\District 08\Preble\100818\400-Engineering\Roadway\Sheets\100818\_G1001.dgn

TITLE SHEET

DESIGN AGENCY	
DESIGNER	GTF
REVIEWER	JDO 4/25/2023
PROJECT ID	100818
SHEET	TOTAL
1	53

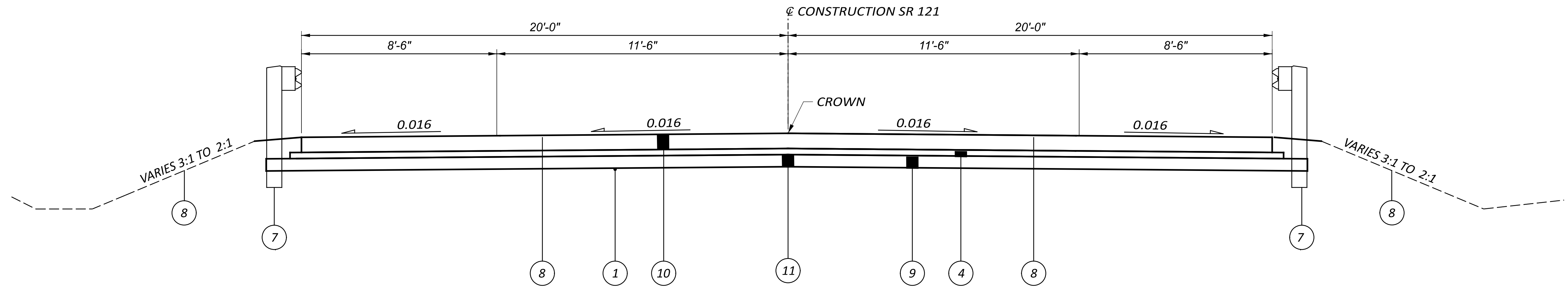

**APPROACH SLAB SECTION**  
 STA. 10+87.28 TO STA. 11+07.28  
 STA. 12+04.82 TO STA. 12+24.82

**NOTES**

- 1) CROSS SLOPE VARIES FROM EX. 0.04± TO 0.016
- 2) SHOULDER WIDTH VARIES FROM 4'-3"± (EX.) AT STA. 10+50.00 TO 8'-6" AT STA. 10+98.25  
 SHOULDER WIDTH VARIES FROM 8'-6" AT STA. 12+36.75 TO 4'-3"± (EX.) AT STA. 13+25.00

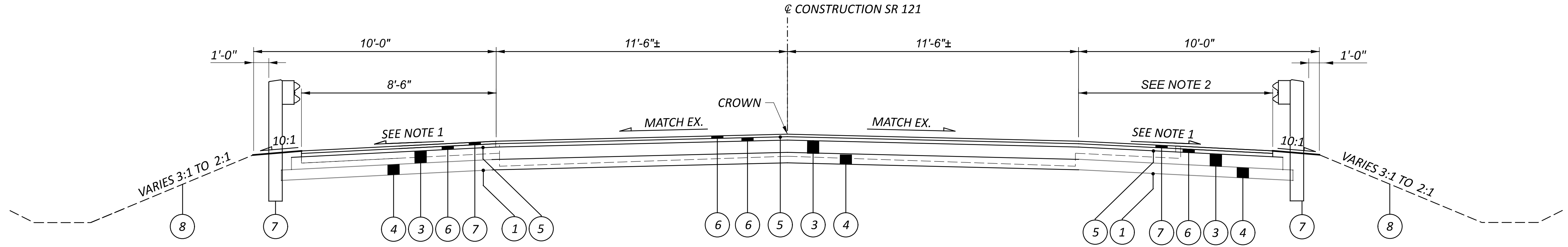

**TYPICAL SECTION - SR 121**  
 FULL DEPTH PAVEMENT REPLACEMENT AND WIDENING  
 STA. 10+62.28 TO STA. 10+87.28  
 STA. 12+24.82 TO STA. 12+49.82

**LEGEND**

- (A) EX. ±5.5" ASPHALT CONCRETE ON ±10" AGGREGATE BASE
- ① ITEM 204 - SUBGRADE COMPACTION
- ② ITEM 254 - PAVEMENT PLANING, ASPHALT CONCRETE (D = 1.5")
- ③ ITEM 301 - 8" ASPHALT CONCRETE BASE, PG64-22 (449)
- ④ ITEM 304 - 6" AGGREGATE BASE
- ⑤ ITEM 407 - NON-TRACKING TACK COAT
- ⑥ ITEM 441 - 1.5" ASPHALT CONCRETE SURFACE COURSE, TYPE 1 (449), PG64-22
- ⑦ ITEM 606 - GUARDRAIL, TYPE MGS
- ⑧ ITEM 659 - SEEDING AND MULCHING
- ⑨ ITEM 204 - EXCAVATION OF SUBGRADE, 12" DEPTH
- ⑩ ITEM 526 - REINFORCED CONCRETE APPROACH SLAB, (T=15")
- ⑪ ITEM 204 - GRANULAR MATERIAL, TYPE C

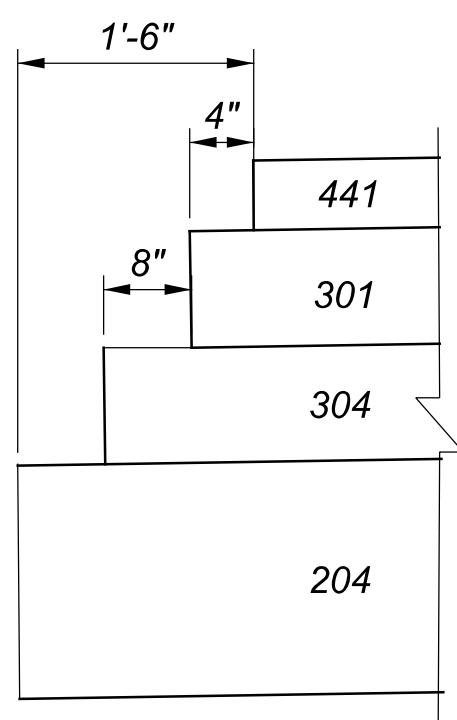

**BASE STEP DETAIL**  
 (NOT TO SCALE)

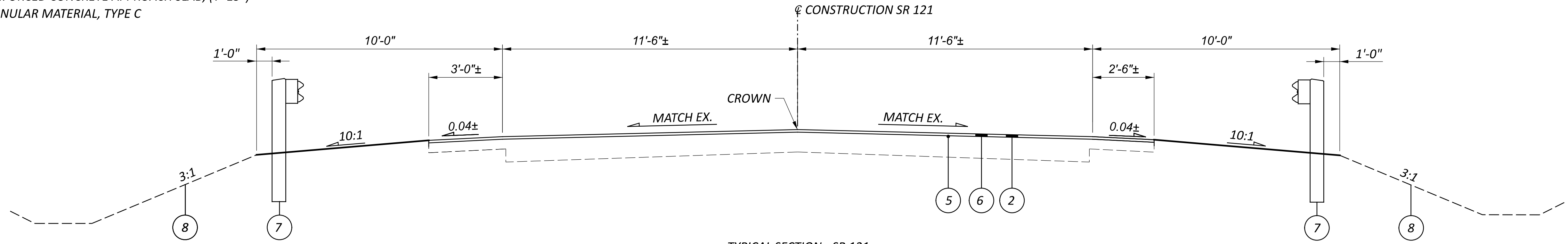

**TYPICAL SECTION - SR 121**  
 PAVEMENT RESURFACING  
 STA. 8+75.00 TO STA. 10+62.28  
 STA. 12+49.82 TO STA. 15+45.00

TYPICAL SECTIONS - PRE-121-0207

DESIGN AGENCY



DESIGNER  
 GTF

REVIEWER  
 JAO 04/25/23

PROJECT ID  
 100818

SHEET TOTAL  
 2 | 53



PHASE NO.	SHEET NO.	STATION		SIDE	LENGTH (FEET)	614							615		622		
		FROM	TO			PAVEMENT REMOVED	WORK ZONE IMPACT ATTENUATOR, 24" WIDE HAZARDS (BI-DIR.)	BARRIER REFLECTOR, TYPE 1 (BI-DIR.)	BARRIER REFLECTOR, TYPE 2 (BI-DIR.)	OBJECT MARKER, TWO-WAY	WORK ZONE CENTER LINE, CLASS 1, 642 PAINT	WORK ZONE EDGE LINE, CLASS 1, 642 PAINT (WHITE)	WORK ZONE STOP LINE, CLASS 1, 642 PAINT	PAVEMENT FOR MAINTAINING TRAFFIC, CLASS B	ROADS FOR MAINTAINING TRAFFIC	PORTABLE BARRIER, UNANCHORED	PORTABLE BARRIER, ANCHORED
						SQ YD	EACH	EACH	EACH	EACH	MILE	MILE	FT	SQ YD	LUMP	FT	FT
1	6	3+25	8+25	CL	500						0.10		12				
1	6	8+75	14+35	LT	560	44			13			0.11		183	LS		
		8+75	14+35	RT	560		2	13	13			0.11				310	160
1	6	14+85	19+85	CL	500						0.10		12				
2	7	3+25	8+25	CL	500						0.10		12				
2	7	8+75	13+75	LT	500		2	11	11			0.09	24			430	
		8+75	13+75	RT	500	103 (REAR) 102 (FWD.)			11	11		0.09		189 (REAR) 165 (FWD.)	LS		
2	7	14+25	19+25	CL	500						0.10		12				
TOTALS CARRIED TO GENERAL SUMMARY						249	4	24	24	48	0.40	0.40	72	350	LS	740	160

**FULLY-ACTUATED OPERATION OF WORK ZONE TRAFFIC SIGNAL**

THE WORK ZONE SIGNAL CONTROL REQUIRED FOR THIS PROJECT AS SHOWN IN THE PLANS AND TRAFFIC SCDS MT- 96.11, 96.20 AND 96.26 SHALL BE FULLY TRAFFIC-ACTUATED AND OPERATE IN A MANNER SIMILAR TO THAT DESCRIBED IN SECTION 733.02 OF THE CONSTRUCTION AND MATERIAL SPECIFICATIONS. THE INITIAL CONTROLLER TIMING SHALL BE AS FOLLOWS:

	PHASE					
	1 (ALL RED) DUMMY PHASE	2 SR 73 (NORTHBOUND)	3 (ALL RED) DUMMY PHASE	4 SR 73 (SOUTHBOUND)	5 (ALL RED) DUMMY PHASE	6 PRIVATE DRIVE STA. 14+00
MIN. GREEN		20		20		5
EXTENSION		3		3		3
MAX. GREEN		30		30		15
YELLOW		6		6		3
ALL RED	X	24	X	24	X	24
RECALL	OFF	ON	OFF	OFF	OFF	OFF

THE CONTRACTOR SHALL ALSO DESIGN, FURNISH, INSTALL AND MAINTAIN A TRAFFIC DETECTOR ON EACH TRAFFIC APPROACH WHICH WILL RELIABLY DETECT ALL LEGAL TRAFFIC APPROACHING (BUT NOT LEAVING) THE SIGNAL AS IT PASSES OR WAITS IN THE DESIGNATED DETECTOR ZONE SHOWN IN THE PLANS. DETECTOR DESIGNS WHICH DO NOT PROVIDE RELIABLE DETECTION, FREE FROM FALSE CALLS, SHALL BE IMMEDIATELY REPLACED BY THE CONTRACTOR.

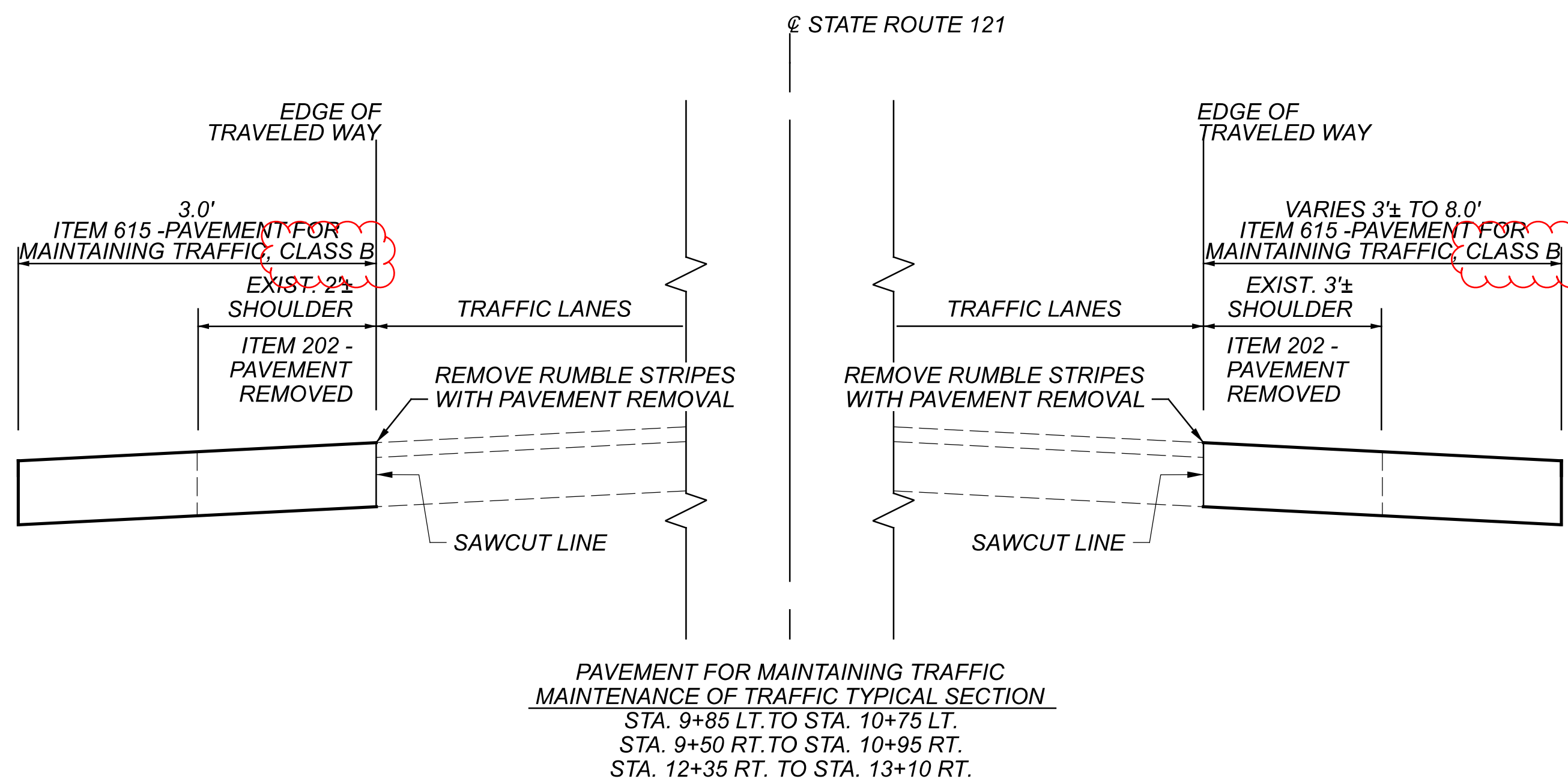

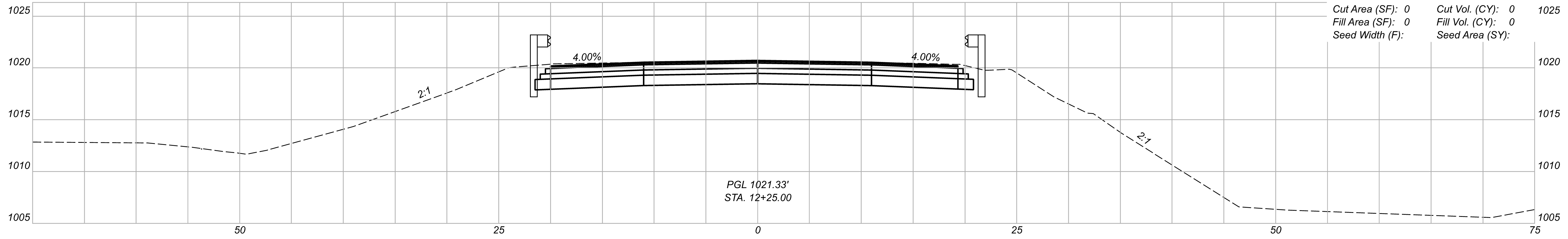
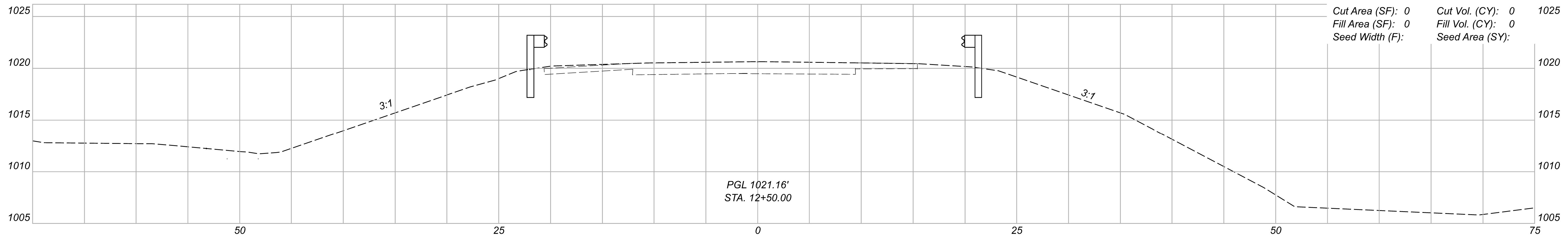

BRIDGE PRE-121-0207

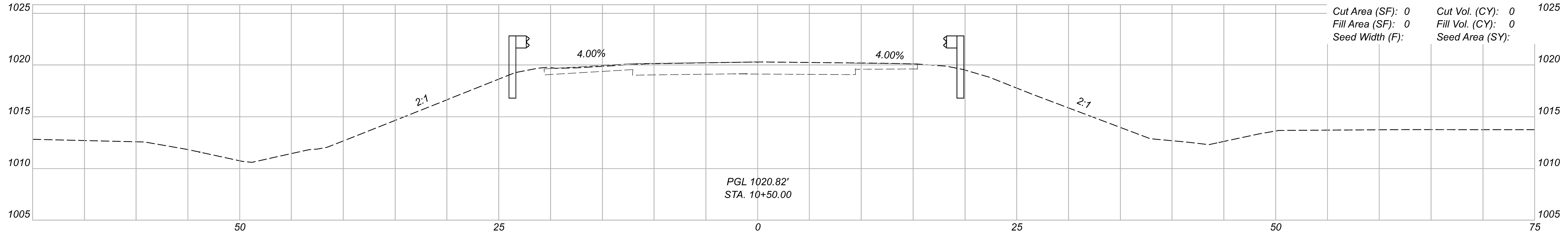
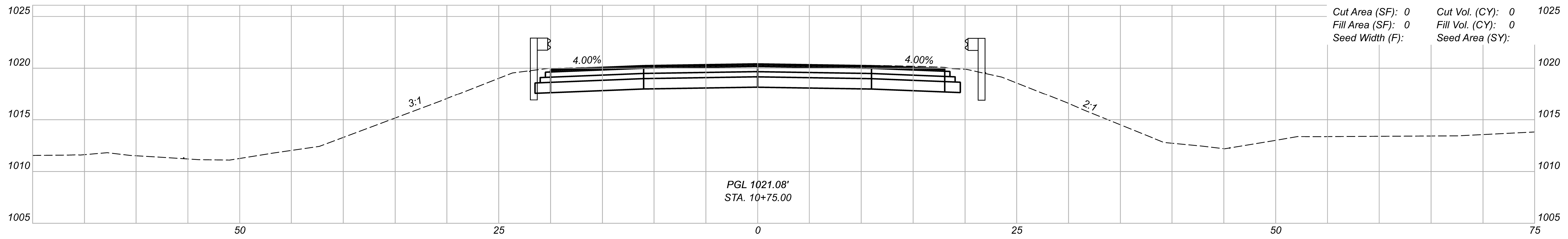

CROSS SECTIONS  
PRE-121-0207 - STA. 10+50.00 TO STA. 12+50.00

DESIGN AGENCY
DESIGNER
GTF
REVIEWER
PROJECT ID
100818
SHEET
19
TOTAL
53



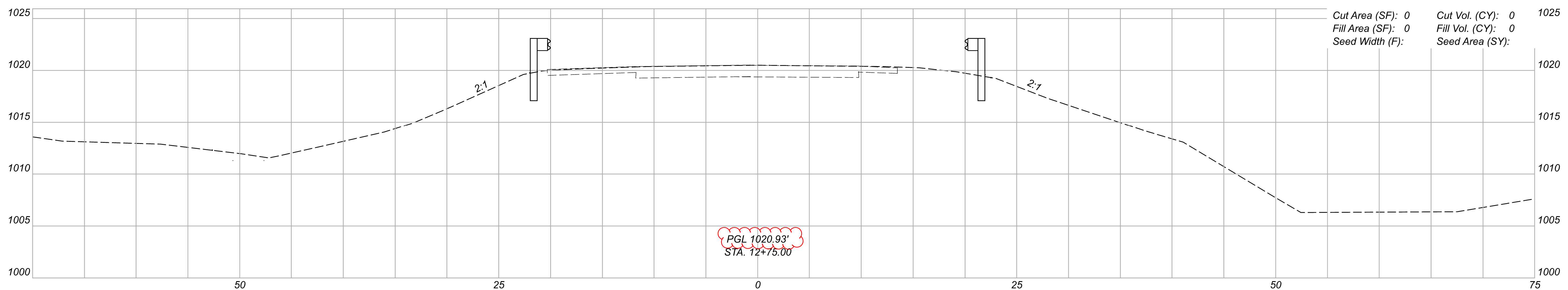
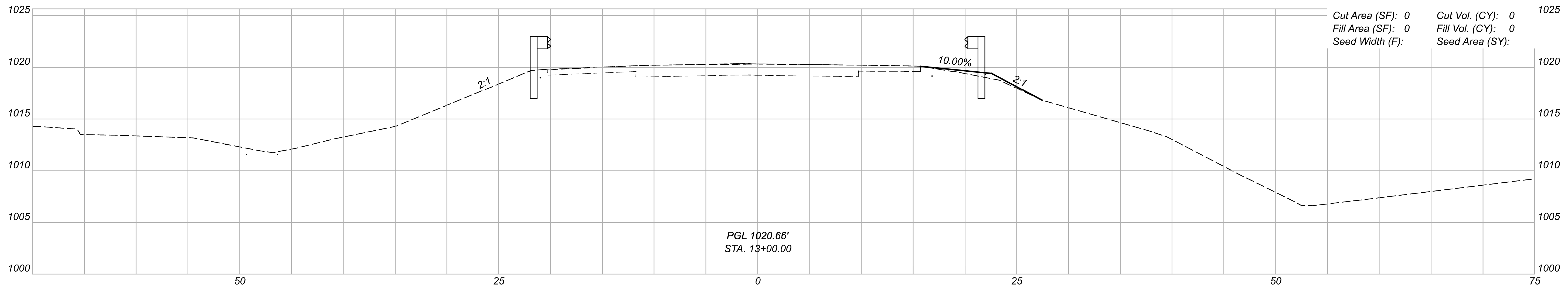
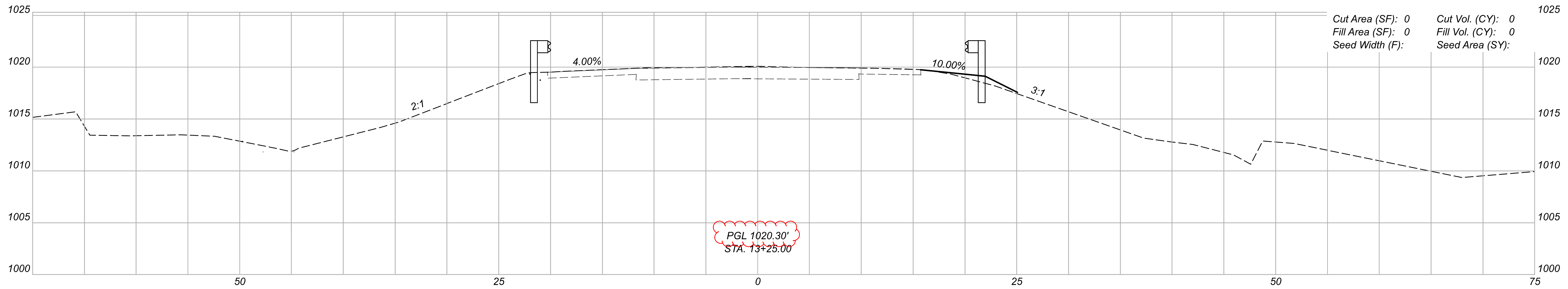

CROSS SECTIONS  
 PRE-121-0207 - STA. 12+75.00 TO STA. 13+25.00

DESIGN AGENCY



DESIGNER

GTF

REVIEWER

PROJECT ID

100818

Sheet Totals		
Seeding	Cut	Fill
.	.	.

SHEET	TOTAL
20	53



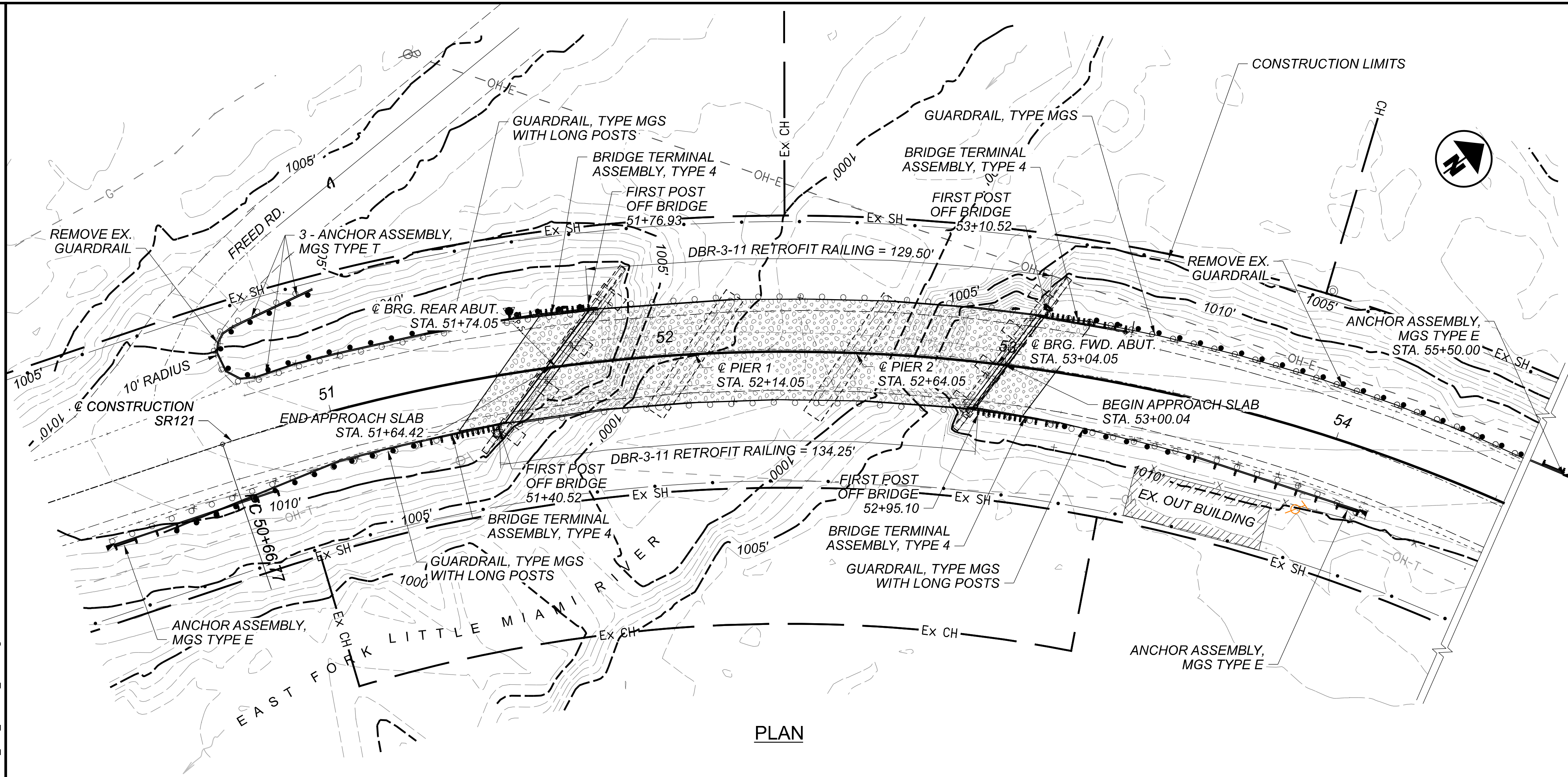

PLAN

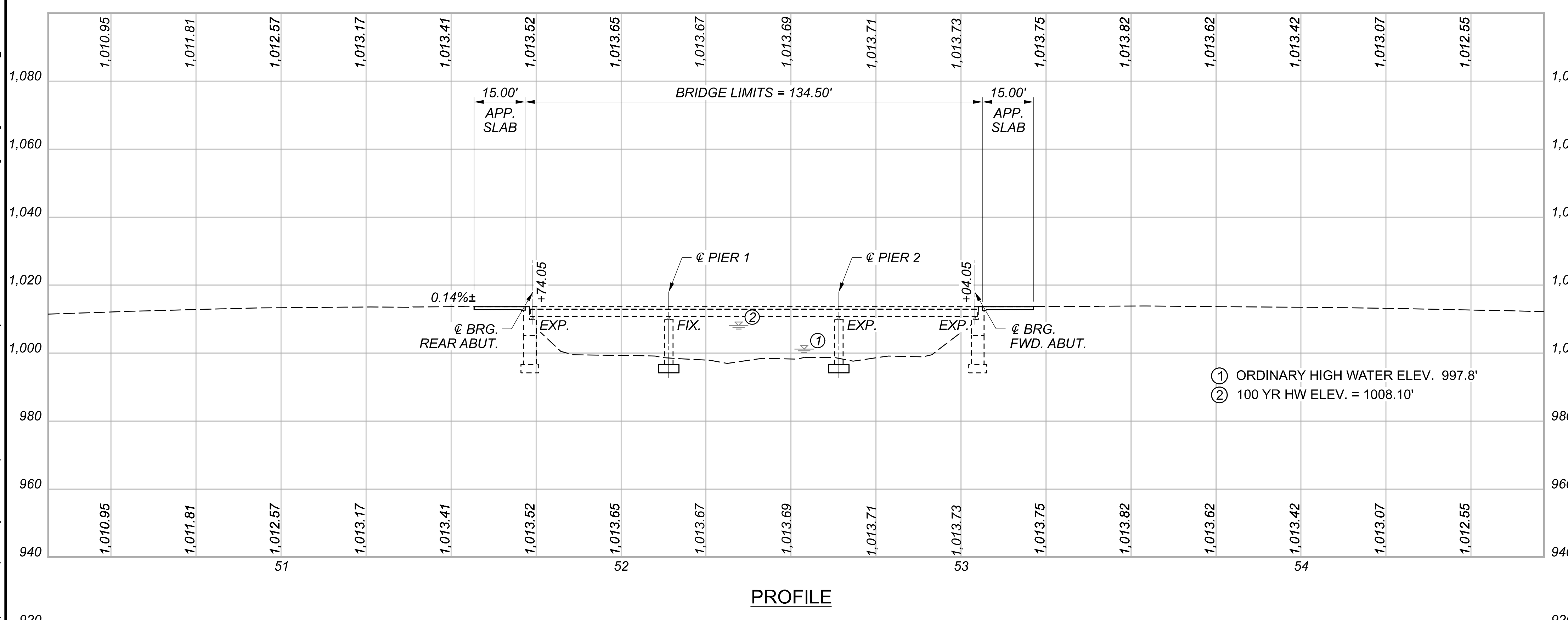

PROFILE

**BENCHMARK DATA**

BM #1 STA. 51+56.43, ELEV. 1014.32, OFFSET -18.16', IPIN  
 BM #2 STA. 55+57.73, ELEV. 1009.89, OFFSET -15.36', IPIN

**DESIGN TRAFFIC**

2023 ADT = 2,200      2023 ADTT = 44  
 2043 ADT = 2,700      2043 ADTT = 54  
 DIRECTIONAL DISTRIBUTION = 0.65

**HYDRAULIC DATA**

DRAINAGE AREA = 33.9 SQ. MILES  
 Q (25) = 5540 CFS  
 Q (100) = 7550 CFS

ORDINARY HIGH WATER MARK ELEVATION = 997.8'

**LEGEND**

ITEM 848 - SUPERPLASTICIZED DENSE CONCRETE OVERLAY USING HYDRODEMOLITION

**EXISTING STRUCTURE**

TYPE: 3-SPAN CONTINUOUS STEEL BEAM WITH REINFORCED CONCRETE DECK AND SUBSTRUCTURE.

SPANS: ±40'-0", ±50'-0", ±40'-0" C/C BRGS. ALONG @ CURVE  
 ROADWAY: 30'-0" F/F GUARDRAIL  
 LOADING: HS20-44 & ALT. MILITARY LOADING  
 SKEW: 37° 30' 00" L.F. ABOUT REF. CHORD  
 WEARING SURFACE: 1" MONOLITHIC CONCRETE  
 APPROACH SLABS: AS-1-81 (15' LONG)  
 ALIGNMENT: 11° 00' RT. CURVE  
 CROWN: SUPERELEVATED  
 STRUCTURE FILE NUMBER: 6801676  
 DATE BUILT: 1991  
 DISPOSITION: SEE PROPOSED WORK

**PROPOSED STRUCTURE**

TYPE: 3-SPAN CONTINUOUS STEEL BEAM WITH REINFORCED CONCRETE DECK AND SUBSTRUCTURE.

SPANS: ±40'-0", ±50'-0", ±40'-0" C/C BRGS. ALONG @ CURVE  
 ROADWAY: 30'-0" F/F GUARDRAIL  
 LOADING: HS20-44 & ALT. MILITARY LOADING  
 SKEW: 37° 30' 00" L.F. ABOUT REF. CHORD  
 WEARING SURFACE: 1 3/4" SUPERPLASTICIZED DENSE CONCRETE OVERLAY  
 APPROACH SLABS: AS-1-81 (15' LONG)  
 ALIGNMENT: 11° 00' RT. CURVE  
 CROWN: SUPERELEVATED  
 DECK AREA: 3,930 SF  
 COORDINATES: LATITUDE 39° 51' 20" N  
 LONGITUDE 84° 47' 59" W

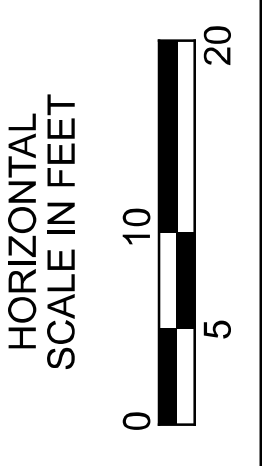

SITE PLAN  
 BRIDGE No.: PRE-121-0098  
 STATE ROUTE 121 OVER EAST FORK WHITEWATER RIVER

SFN	6801676
DESIGN AGENCY	
DESIGNER/CHECKER	GTF AS
REVIEWER	CAH 03/28/23
PROJECT ID	100818
SUBSET	TOTAL
1	11
SHEET	TOTAL
23	53



**STANDARD DRAWINGS AND SUPPLEMENTAL SPECIFICATIONS**

REFER TO THE FOLLOWING STANDARD BRIDGE DRAWING(S):

EXJ-4-87	DATED/REVISED	7/15/22
PCB-91	DATED/REVISED	7/17/20
DBR-3-11	DATED/REVISED	7/15/11
DS-1-92	DATED/REVISED	7/18/03
GSD-1-19	DATED/REVISED	1/15/21

AND TO THE FOLLOWING SUPPLEMENTAL SPECIFICATIONS

800	DATED 4/21/2023
848	DATED 1/15/2021

**DESIGN SPECIFICATIONS**

THIS STRUCTURE CONFORMS TO THE 9th EDITION OF THE "LRFD BRIDGE DESIGN SPECIFICATIONS" ADOPTED BY THE AMERICAN ASSOCIATION OF STATE HIGHWAY AND TRANSPORTATION OFFICIALS, 2020 AND THE ODOT BRIDGE DESIGN MANUAL, 2020.

**DESIGN LOADING**

DESIGN LOADING INCLUDES:  
VEHICULAR LIVE LOAD: HS20-44 & ALT. MILITARY LOADING

**DESIGN DATA**

CONCRETE CLASS QC2  
-COMPRESSIVE STRENGTH 4.5 KSI (SUPERSTRUCTURE)

**DECK PROTECTION METHOD**

GALVANIZED STEEL REINFORCEMENT  
2½" CONCRETE COVER  
STEEL DRIP STRIP  
SEALING OF CONCRETE SURFACES

**ITEM 202 - PORTIONS OF STRUCTURE REMOVED, OVER 20 FOOT SPAN, AS PER PLAN**

THIS WORK CONSISTS OF THE PARTIAL REMOVAL OF CONCRETE DECKS, AS WELL AS THE REMOVAL OF DECK JOINTS, EXISTING END CROSS FRAMES. THE PROVISIONS OF ITEM 202 APPLY EXCEPT AS SPECIFIED BY THE FOLLOWING NOTES. GRIND WELD REMNANTS FLUSH WITH THE SURROUNDING SURFACE AFTER WELD ATTACHEMENTS (e.g. COMPRESSION SEAL RETAINERS AND END CROSSFRAMES) ARE REMOVED. PERFORM WORK CAREFULLY DURING DECK REMOVALS TO PROTECT PORTIONS OF SUCH SYSTEMS THAT ARE TO BE SALVAGED AND INCORPORATED INTO THE PROPOSED STRUCTURE (BEAMS, GIRDERS, SHEAR STUDS, PARAPET REINFORCING STEEL, ETC.) HEADACHE BALLS AN/OR HOW RAM TYPE OF EQUIPMENT IS PROHIBITED. TO ENSURE THE PROTECTION OF PUBLIC WELFARE, OR LIFE, HEALTH OR PROPERTY THE CONTRACTOR SHALL SUBMIT ENGINEERED DRAWINGS TO THE ENGINEER FOR APPROVAL PER 501.05B.

PROTECTION OF STEEL SUPPORT SYSTEMS: BEFORE DECK SLAB CUTTING IS PERMITTED, DRAW THE OUTLINE OF THE PRIMARY STEEL MEMBERS IN CONTACT WITH THE BOTTOM OF THE DECK ON THE SURFACE OF THE DECK. DRILL SMALL DIAMETER PILOT HOLES 2 INCHES OUTSIDE THESE LINES TO CONFIRM THE LOCATION OF FLANGE EDGES. DECK CUTS OVER OR WITHIN 2 INCHES OF FLANGE EDGES SHALL NOT EXTEND LOWER THAN THE BOTTOM LAYER OF DECK SLAB REINFORCING STEEL. CUTS MADE OUTSIDE 2 INCHES OF FLANGE EDGES MAY EXTEND THE FULL DEPTH OF THE DECK. REPLACE OR REPAIR STEEL MEMBERS DAMAGED BY THE DECK SLAB CUTTING OPERATIONS AT NO COST TO THE PROJECT. AT LEAST 7 DAYS BEFORE PERFORMING REPAIR WORK, SUBMIT A PROPOSED REPAIR PLAN, DEVELOPED BY AN OHIO REGISTERED PROFESSIONAL ENGINEER TO THE ENGINEER. THE ENGINEERS APPROVAL SHALL BE OBTAINED BEFORE PERFORMING THE REPAIR.

REMOVAL METHODS: THE CONTRACTOR MAY REMOVE CONCRETE BY CUTTING AND BY MEANS OF HAND OPERATED PNEUMATIC HAMMERS EMPLOYING POINTED OR BLUNTED CHISEL TYPE TOOLS. FOR REMOVALS OVER STRUCTURAL MEMBERS, THE CONTRACTOR MAY USE A HAMMER HEAVIER THAN 35 POUNDS BUT NOT EXCEED 90 POUNDS UNLESS APPROVED BY THE ENGINEER. REMOVAL METHODS OVER STRUCTURAL MEMBERS SHALL ENSURE ADEQUATE DEPTH CONTROL AND PREVENT NICKING OR GOUGING THE PRIMARY STRUCTURAL MEMBERS.

THE CONTRACTOR MUST REVIEW THE STRUCTURE WHEN PREPARING HIS BID. THE CONTRACTOR WILL REVIEW THE CONDITION OF THE STRUCTURE TO DETERMINE WHAT DEBRIS WILL FALL FROM THE STRUCTURE DURING REMOVAL. THE CONTRACTOR WILL DETERMINE THE CORRESPONDING COST TO CLEAN UP ANY AND ALL DEBRIS DURING REMOVAL OPERATIONS. THE COST TO CLEAR AND CLEAN UP ALL DEBRIS DURING REMOVAL SHALL BE INCLUDED WITH THE BID FOR THIS ITEM OF WORK. NO ADDITIONAL COST WILL BE RECOGNIZED TO CLEAN DEBRIS RESULTING FROM THE STRUCTURE REMOVAL OPERATION.

REMOVALS OF EXISTING CROSSFRAMES: FLAME OR SAW CUT THE EXISTING MEMBERS TO WITHIN ¼" OF THE EXISTING MAIN MATERIAL USING A MECHANICAL GUIDE ACCORDING TO C&MS 513.12. PROVIDE SHEILDING IF NECESSARY TO PREVENT DAMAGE TO MAIN OR SECONDARY MATERIALS THAT REMAIN. GRIND THE EXISTING MAIN OR SECONDARY MEMBER SMOOTH IN PREPARATION FOR COMPLETE PENETRATION OR FILLET WELDING. PROVIDE A SURFACE FINISH ACCORDING TO ANSI B46.1 OF 250 MIL.

MEASUREMENT & PAYMENT: THE DEPARTMENT WILL MEASURE THE QUANTITY OF REMOVALS ON A LUMP SUM BASIS. THE DEPARTMENT WILL PAY FOR THE ACCEPTED QUANTITIES OF REMOVALS AT THE CONTRACT PRICE FOR ITEM 202 - PORTIONS OF STRUCTURE REMOVED, OVER 20 FOOT SPAN, AS PER PLAN.

**EXISTING STRUCTURE VERIFICATION**

EXISTING STRUCTURE VERIFICATION: DETAILS AND DIMENSIONS SHOWN ON THESE PLANS PERTAINING TO THE EXISTING STRUCTURE HAVE BEEN OBTAINED FROM PLANS OF THE EXISTING STRUCTURE AND FROM FIELD OBSERVATIONS AND MEASUREMENTS. CONSEQUENTLY, THEY ARE INDICATIVE OF THE EXISTING STRUCTURE AND THE PROPOSED WORK BUT THEY SHALL BE CONSIDERED TENTATIVE AND APPROXIMATE. BEFORE ORDERING MATERIALS EXISTING DIMENSIONS SHALL BE FIELD VERIFIED AS REQUIRED TO ACCURATELY JOIN THE PROPOSED ELEMENTS WITH THE EXISTING STRUCTURE. PAYMENT FOR THE FIELD VERIFICATION SHALL BE COMPENSATED UNDER THE RESPECTIVE PAY ITEM FOR THAT WORK. THE CONTRACTOR IS REFERRED TO CMS SECTIONS 102.05, 105.02 AND 513.04.

BASE CONTRACT BID PRICES UPON A RECOGNITION OF THE UNCERTAINTIES DESCRIBED ABOVE AND UPON A PREBID EXAMINATION OF THE EXISTING STRUCTURE. HOWEVER, THE DEPARTMENT WILL PAY FOR ALL PROJECT WORK BASED UPON ACTUAL DETAILS AND DIMENSIONS WHICH HAVE BEEN VERIFIED IN THE FIELD.

**ITEM 509 - CONCRETE REINFORCEMENT, REPLACEMENT OF EXISTING CONCRETE REINFORCEMENT, AS PER PLAN**

REPLACE ALL EXISTING REINFORCING BARS DEEMED BY THE ENGINEER TO BE UNUSABLE BECAUSE OF CORROSION. THE DEPARTMENT WILL MEASURE THE REPLACEMENT REINFORCING STEEL BY THE NUMBER OF POUNDS ACCEPTED IN PLACE. REPLACE ALL EXISTING REINFORCING STEEL BARS WHICH ARE TO BE INCORPORATED INTO THE NEW WORK AND ARE DEEMED BY THE ENGINEER TO BE MADE UNUSABLE BY CONCRETE REMOVAL OPERATIONS WITH NEW REINFORCING STEEL OF THE SAME SIZE AND COATING AT NO COST TO THE DEPARTMENT. ADDITIONAL QUANTITIES HAVE BEEN PROVIDED FOR DOWEL HOLES, IF NEEDED, TO EMBED THE REPLACEMENT REINFORCING INTO THE EXISTING STRUCTURE. PAYMENT FOR DOWEL HOLES SHALL BE MADE AT THE BID UNIT PRICE FOR ITEM 510 DOWEL HOLES WITH NONSHRINK, NONMETALLIC GROUT.

**ITEM 519 - PATCHING CONCRETE STRUCTURES, AS PER PLAN**

PATCHING LOCATIONS AND AREAS SHOWN IN THE PLANS ARE APPROXIMATE. PATCHING QUANTITIES CARRIED TO THE ESTIMATED QUANTITIES HAVE BEEN INCREASED BY 50% TO ACCOUNT FOR ADDITIONAL AREAS REQUIRING PATCHING THAT MAY HAVE DEVELOPED SINCE THE MOST RECENT INSPECTION. THE CONTRACTOR SHALL SOUND THE SURROUNDING PERIMETER OF THE AREA TO BE PATCHED AND PATCH NEW AREAS APPROVED BY THE ENGINEER THAT HAVE NOT BEEN DETAILED IN THE PLANS.

PRIOR TO THE SURFACE CLEANING SPECIFIED IN C&MS 519.04 AND WITHIN 24 HOURS OF PLACING PATCHING MATERIAL, BLAST CLEAN ALL SURFACES TO BE PATCHED INCLUDING THE EXPOSED REINFORCING STEEL. ACCEPTABLE METHODS INCLUDE: HIGH-PRESSURE WATER BLASTING WITH, OR WITHOUT, ABRASIVES IN THE WATER, ABRASIVE BLASTING WITH CONTAINMENT OR VACUUM ABRASIVE BLASTING.

MEASUREMENT AND PAYMENT: THE PLAN QUANTITIES INCLUDE AN INCREASE OF THE FIELD MEASURED QUANTITIES. THE ACCEPTED QUANTITIES FOR THE COMPLETED WORK AS DESCRIBED WILL BE MEASURED AND PAID BY ITEM 519 - PATCHING CONCRETE STRUCTURE, AS PER PLAN.

**PROPOSED WORK**

1. REMOVE 1.25" OF THE EXISTING DECK AND APPROACH SLAB USING HYDRODEMOLITION. CONSTRUCT 1.75" SUPERPLASTICIZED DENSE CONCRETE OVERLAY ON THE DECK AND APPROACH SLABS.
2. REPLACE EXISTING EXPANSION JOINTS, THE TOP OF THE BACKWALL DOWN TO THE APPROACH SLAB SEATS, AND THE LAST 4 FEET OF THE DECK.
3. RETROFIT EXISTING BRIDGE RAILING PER STANDARD DRAWING DBR-3-11.
4. PATCH THE EXISTING SUBSTRUCTURE.
5. PAINT STRUCTURAL STEEL TO MATCH EXISTING COLOR
6. SEAL DECK EDGES, ABUTMENTS, AND 4 FEET OF THE PIER ENDS WITH EPOXY URETHANE SEALER, FEDERAL COLOR 17778.
7. REPLACE THE APPROACH GUARDRAIL, BRIDGE TERMINAL ASSEMBLIES, AND END TERMINAL ASSEMBLIES.

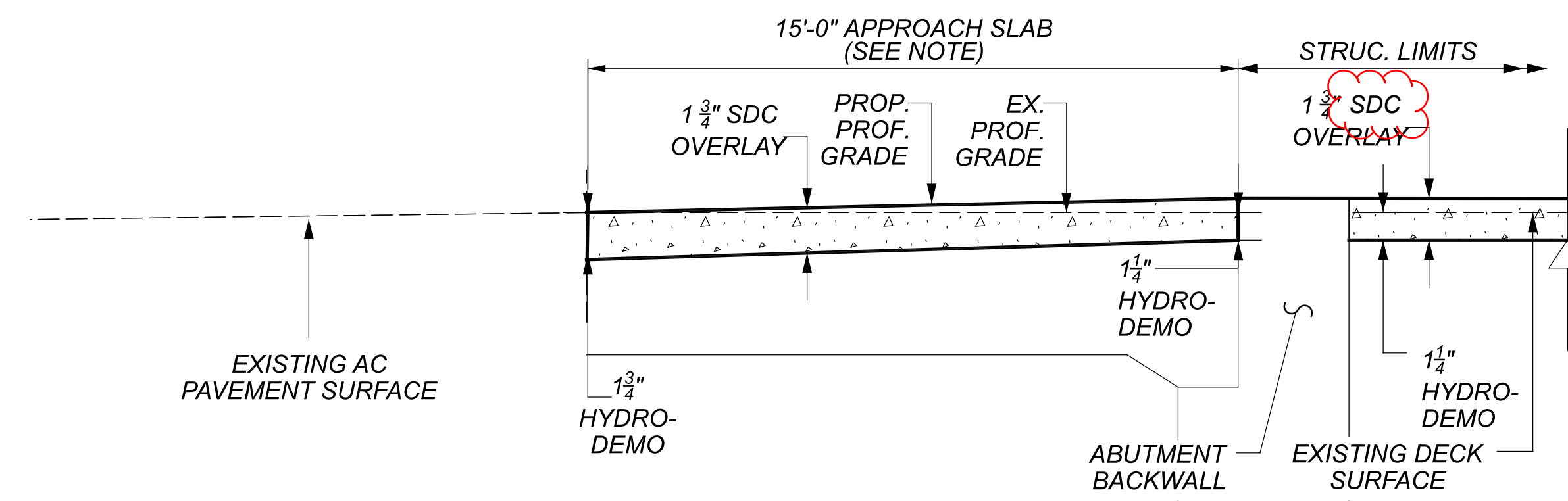

**LEGEND**

- SUPERPLASTICIZED DENSE CONCRETE OVERLAY

**NOTE**

VARY DEPTH OF HYDRO-DEMOLITION FROM 1.75" AT THE APPROACH PAVEMENT END TO 1.25" AT THE BRIDGE END

**PRE-121-0098 TRANSITION DETAIL  
(TYPICAL REAR & FWD. APPROACH SLAB)**

STRUCTURE GENERAL NOTES  
BRIDGE No.: PRE-121-0098  
STATE ROUTE 121 OVER EAST FORK WHITEWATER RIVER

SFN  
6801676  
DESIGN AGENCY



DESIGNER	CHECKER
GTF	AS
REVIEWER	
CAH	03/28/23
PROJECT ID	
100818	
SUBSET	TOTAL
2	11
SHEET	TOTAL
24	53



ESTIMATED QUANTITIES - STRUCTURE No.: PRE-121-0098 (01/STR/13 FUNDING SPLIT)									
ITEM	EXTENSION	TOTAL	UNIT	DESCRIPTION	ABUT.	PIERS	SUPER.	GEN.	SEE SHEET
202	11203	LS	LS	PORTIONS OF STRUCTURE REMOVED, OVER 20 FOOT SPAN, AS PER PLAN			LUMP		24
509	10000	464	LB	EPOXY COATED STEEL REINFORCEMENT	117		347		
509	20001	100	LB	CONCRETE REINFORCMENT, REPLACEMENT OF EXISTING CONCRETE REINFORCEMENT, AS PER PLAN	50		50		24
510	10001	10	EACH	DOWEL HOLES WITH NON-SHRINK, NON-METALLIC GROUT, AS PER PLAN	5		5		24
511	34412	13	CY	CLASS QC2 CONCRETE WITH QC/QA, SUPERSTRUCTURE	4		9		
512	10100	243	SY	SEALING OF CONCRETE SURFACES (EPOXY-URETHANE)	125	64	54		
512	74000	230	SY	REMOVAL OF EXISTING COATINGS FROM CONCRETE SURFACES	125		105		
513	10200	2081	LB	STRUCTURAL STEEL MEMBERS, LEVEL UF			2081		
514	00050	4594	SF	SURFACE PREPARATION OF EXISTING STRUCTURAL STEEL			4,594		
514	00056	4594	SF	FIELD PAINTING OF EXISTING STRUCTURAL STEEL, PRIME COAT			4,594		
514	00060	4816	SF	FIELD PAINTING STRUCTURAL STEEL, INTERMEDIATE COAT			4,816		
514	00066	4816	SF	FIELD PAINTING STRUCTURAL STEEL, FINISH COAT			4,816		
514	00504	16	MNHR	GRINDING FINS, TEARS, SLIVERS ON EXISTING STRUCTURAL STEEL			16		
514	10000	6	EACH	FINAL INSPECTION REPAIR			6		
516	10000	76	FT	PREFORMED ELASTOMERIC COMPRESSION JOINT SEAL			76		
516	11210	76	FT	STRUCTURAL EXPANSION JOINT INCLUDING ELASTOMERIC STRIP SEAL			76		
SPECIAL	518E22300	352	FT	SPECIAL - STEEL DRIP STRIP			352		
517	75600	264	FT	DEEP BEAM BRIDGE RETROFIT RAILING			264		
519	11101	60	SF	PATCHING CONCRETE STRUCTURE, AS PER PLAN	15	45			24
848	10200	564	SY	SUPERPLASTICIZED DENSE CONCRETE OVERLAY USING HYDRODEMOLITION (1.75" THICK)			564		
848	20000	564	SY	SURFACE PREPARATION USING HYDRODEMOLITION			564		
848	30200	13	CY	SUPERPLASTICIZED DENSE CONCRETE OVERLAY (VARIABLE THICKNESS), MATERIAL ONLY			13		
848	50000	13	SY	HAND CHIPPING			13		
848	50100	LS	LS	TEST SLAB					

STRUCTURE ESTIMATED QUANTITIES  
 BRIDGE No.: PRE-121-0098  
 STATE ROUTE 121 OVER EAST FORK WHITEWATER RIVER

SFN	6801676
DESIGN AGENCY	
DESIGNER	CHECKER
GTF	AS
REVIEWER	CAH 03/28/23
PROJECT ID	100818
SUBSET	TOTAL
3	11
SHEET	TOTAL
25	53



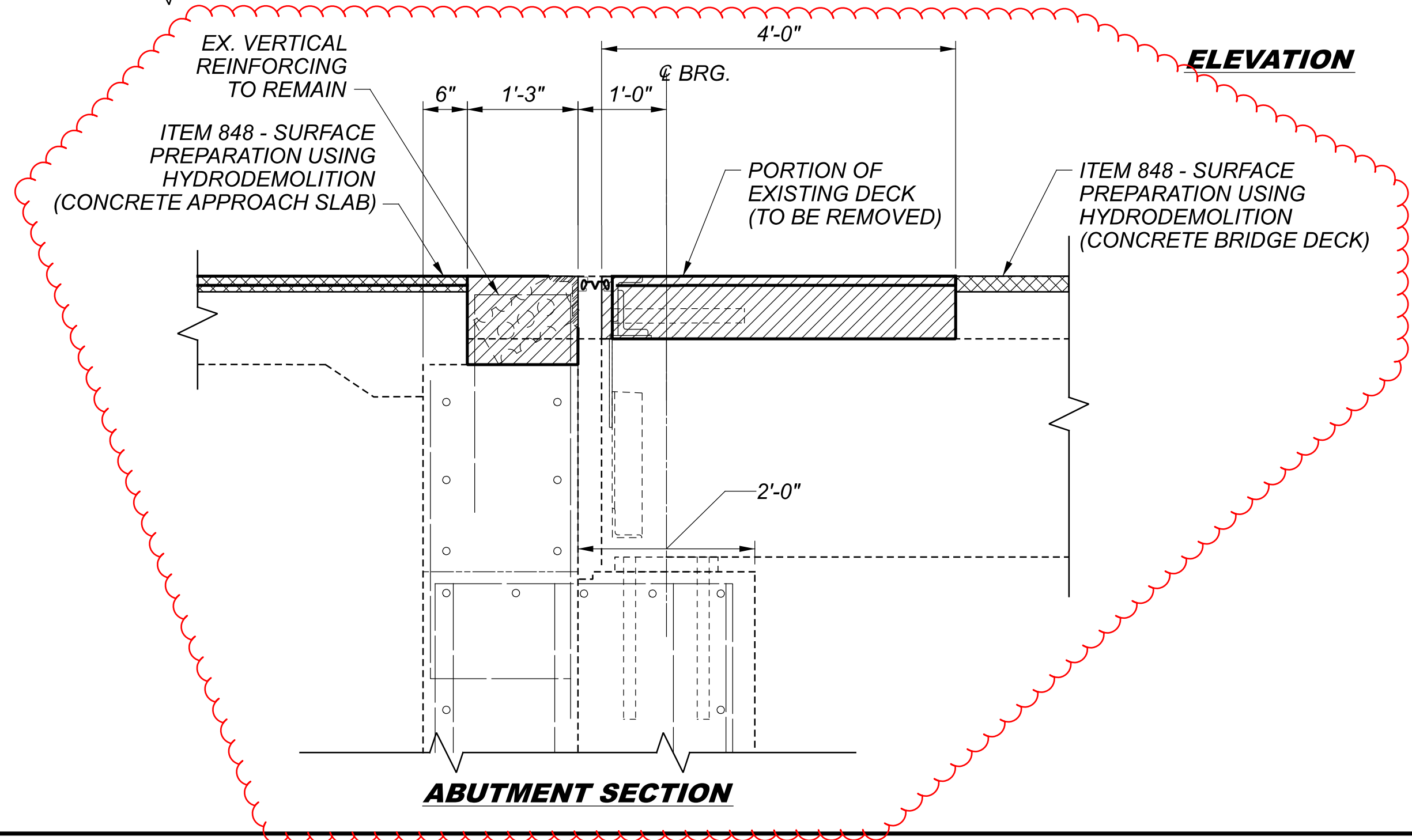
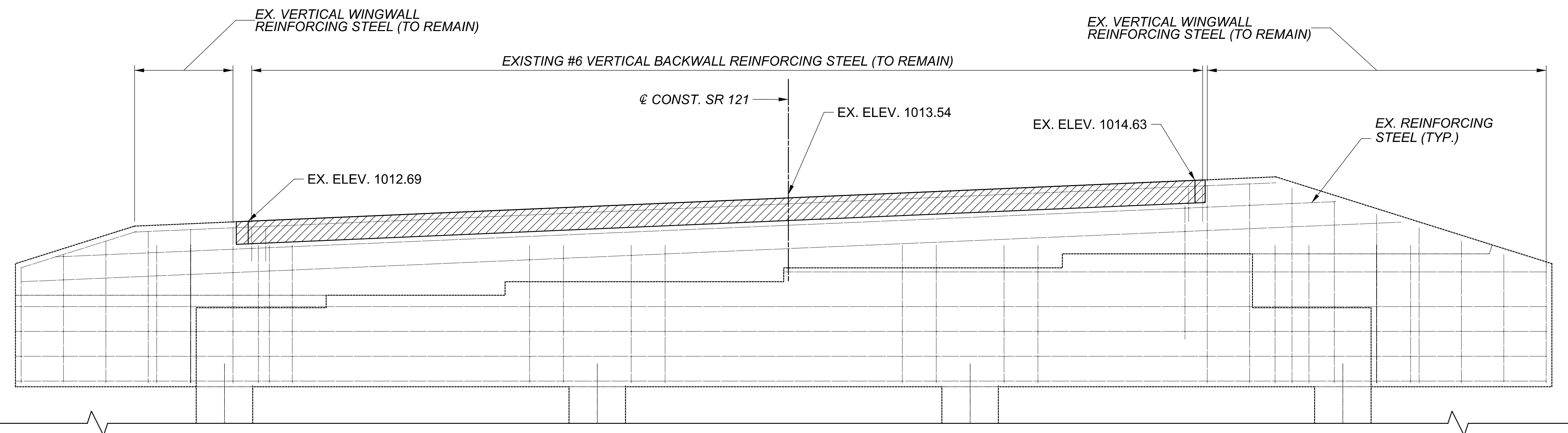
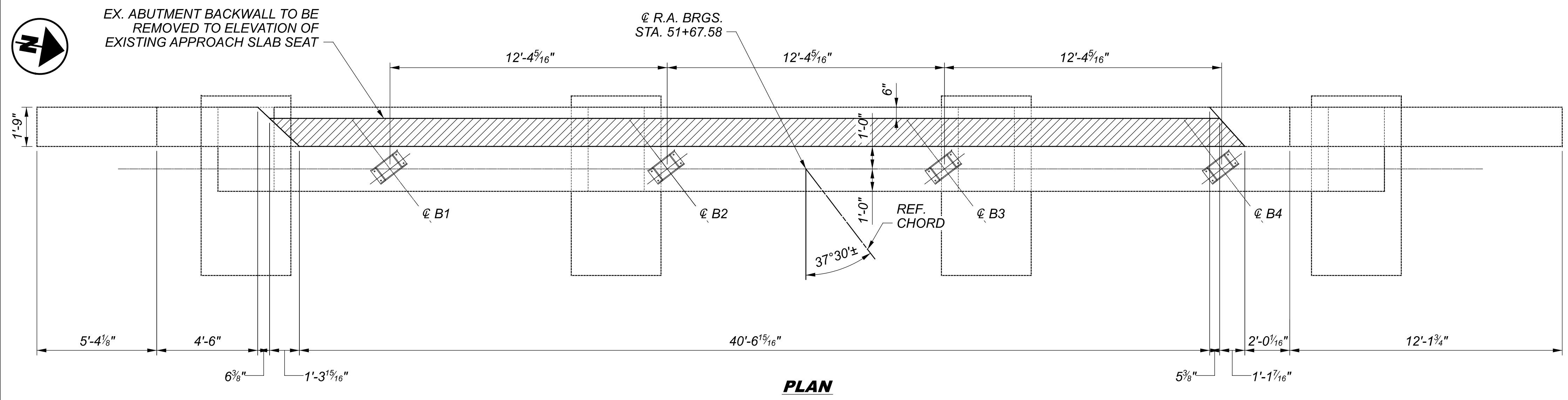

**LEGEND**

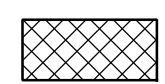
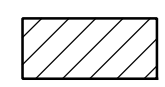
-  ITEM 848 - SURFACE PREPARATION USING HYDRODEMOLITION
-  LIMITS OF REMOVAL PER ITEM 202 - PORTIONS OF STRUCTURE REMOVED, OVER 20 FOOT SPAN, AS PER PLAN

SFN	
6801676	
DESIGN AGENCY	
	
DESIGNER	CHECKER
GTF	AS
REVIEWER	
CAH 03/28/23	
PROJECT ID	
100818	
SUBSET	TOTAL
4	11
SHEET	TOTAL
19	40

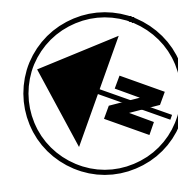

EX. ABUTMENT BACKWALL TO BE REMOVED TO ELEVATION OF EXISTING APPROACH SLAB SEAT

¢ F.A. BRGS. STA. 58+97.44

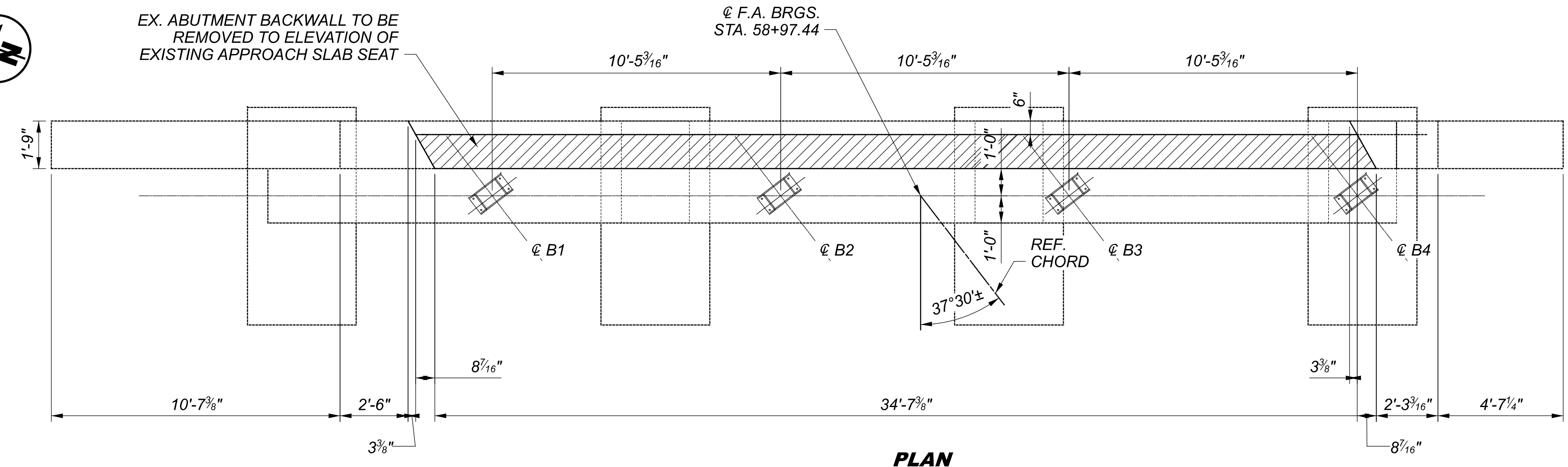

**PLAN**

EX. VERTICAL WINGWALL REINFORCING STEEL (TO REMAIN)

EXISTING #6 VERTICAL BACKWALL REINFORCING STEEL (TO REMAIN)

EX. VERTICAL WINGWALL REINFORCING STEEL (TO REMAIN)

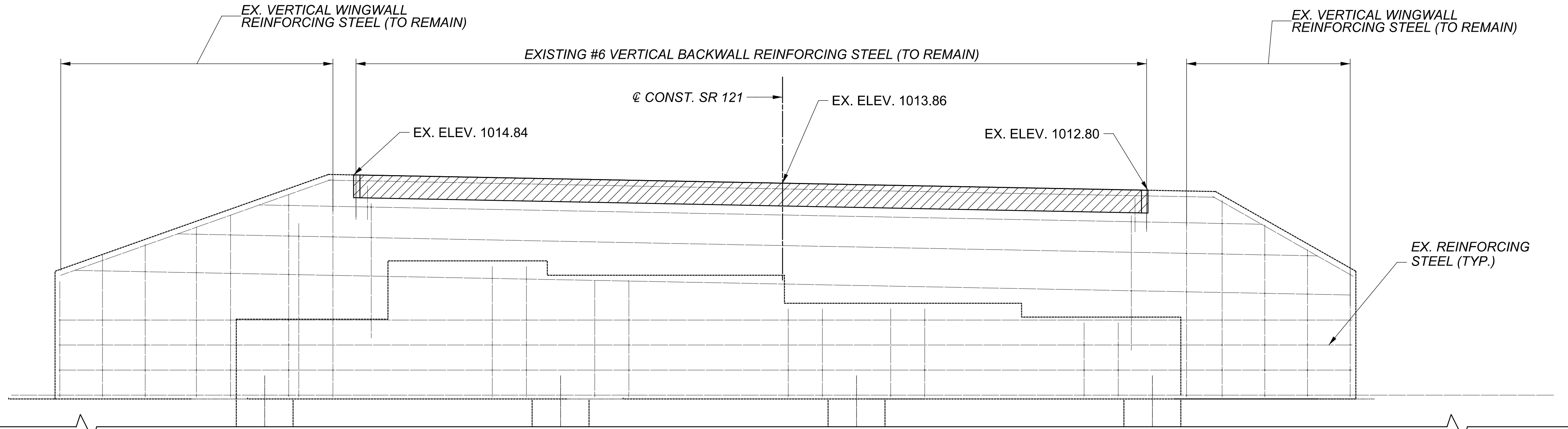

**ELEVATION**

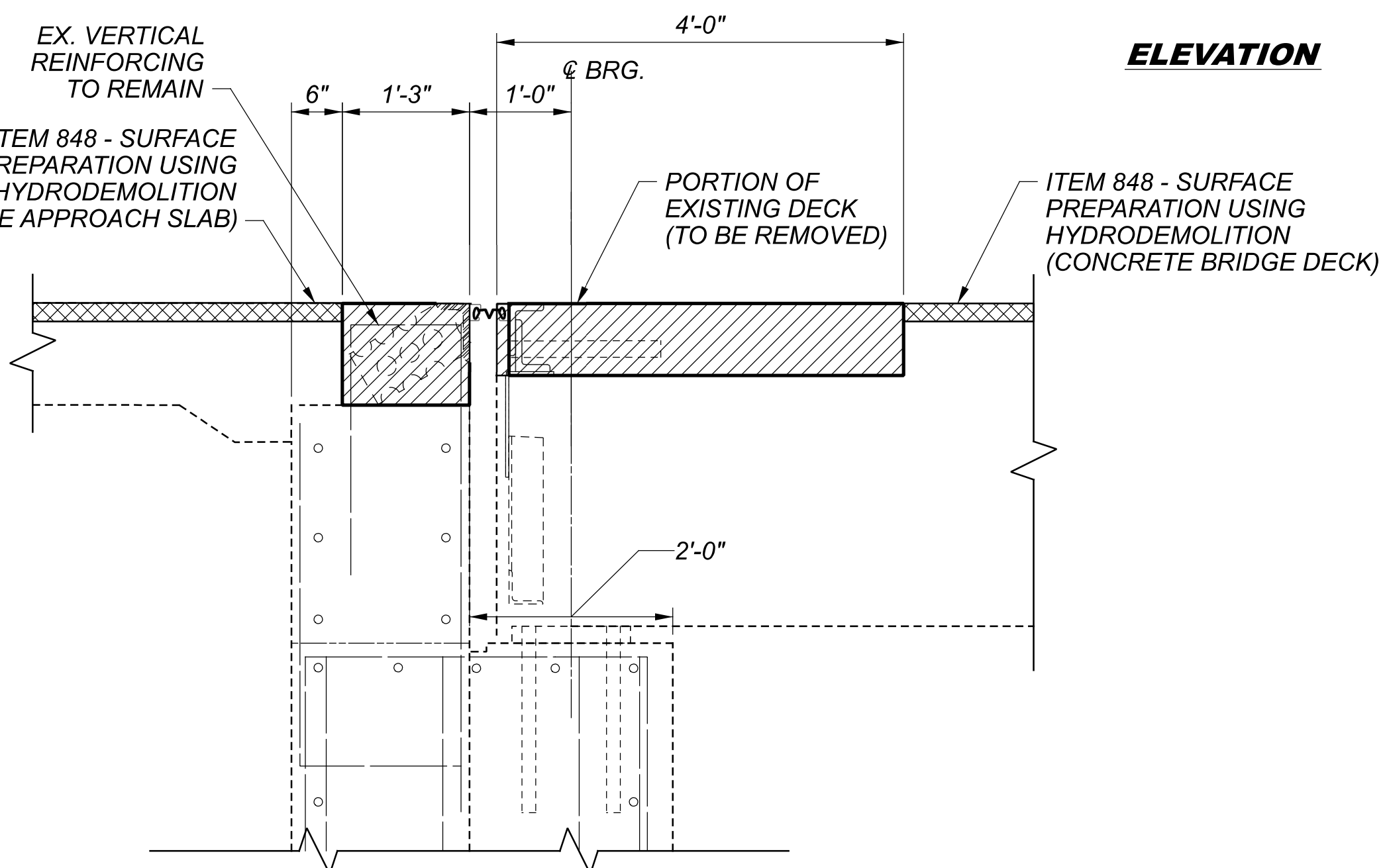

**ABUTMENT SECTION**

**LEGEND**

- ITEM 848 - SURFACE PREPARATION USING HYDRODEMOLITION
- LIMITS OF REMOVAL PER ITEM 202 - PORTIONS OF STRUCTURE REMOVED, OVER 20 FOOT SPAN, AS PER PLAN

SFN  
6801676  
DESIGN AGENCY



DESIGNER	CHECKER
GTF	AS
REVIEWER	CAH 03/28/23
PROJECT ID	100818
SUBSET	TOTAL
5	11
SHEET	TOTAL
27	53



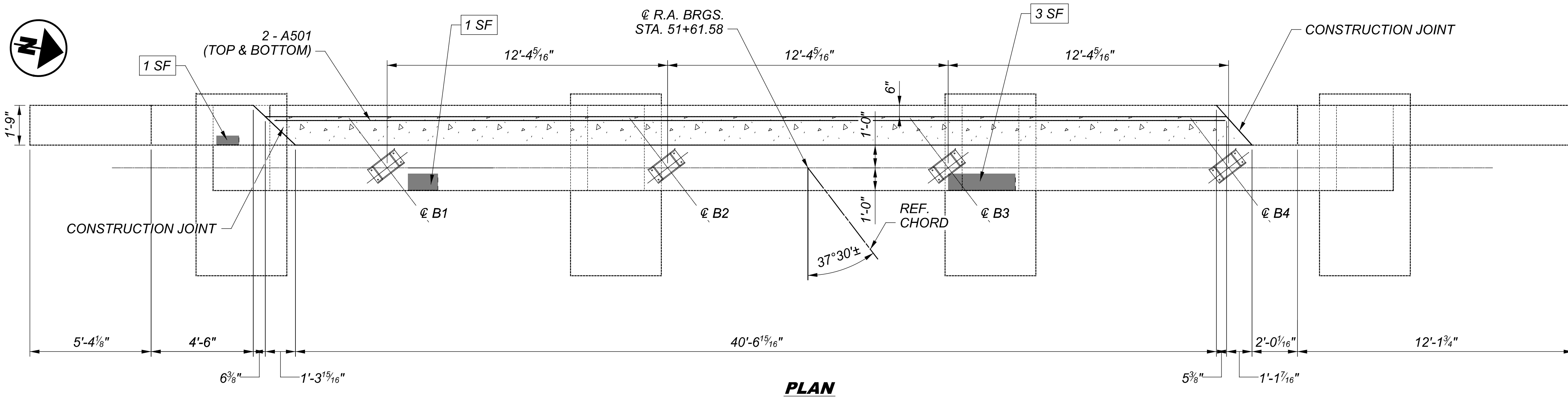

**PLAN**

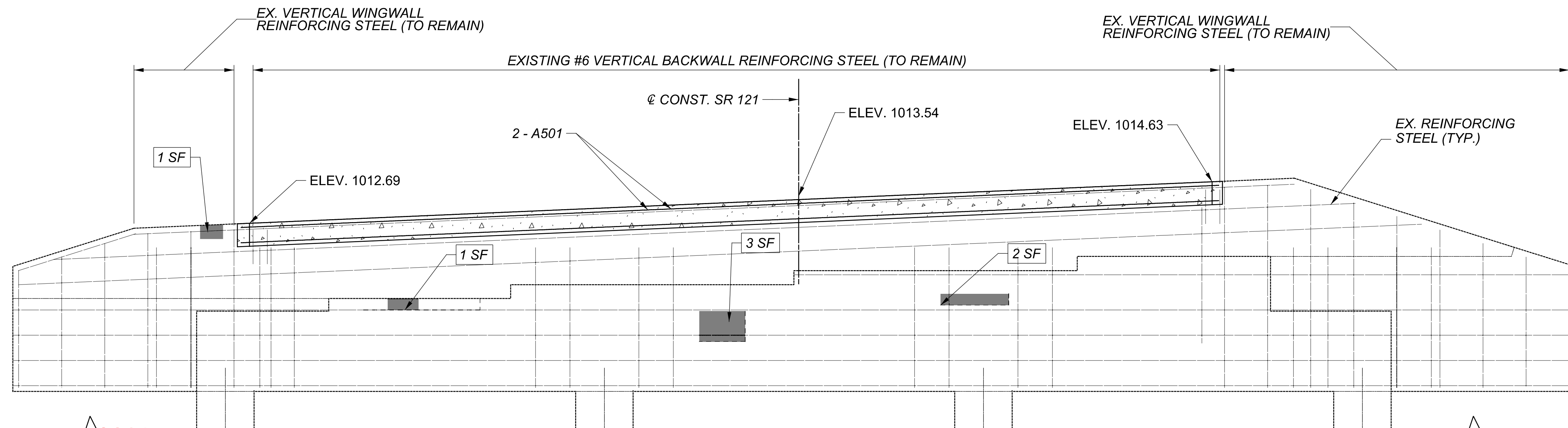

**ELEVATION**

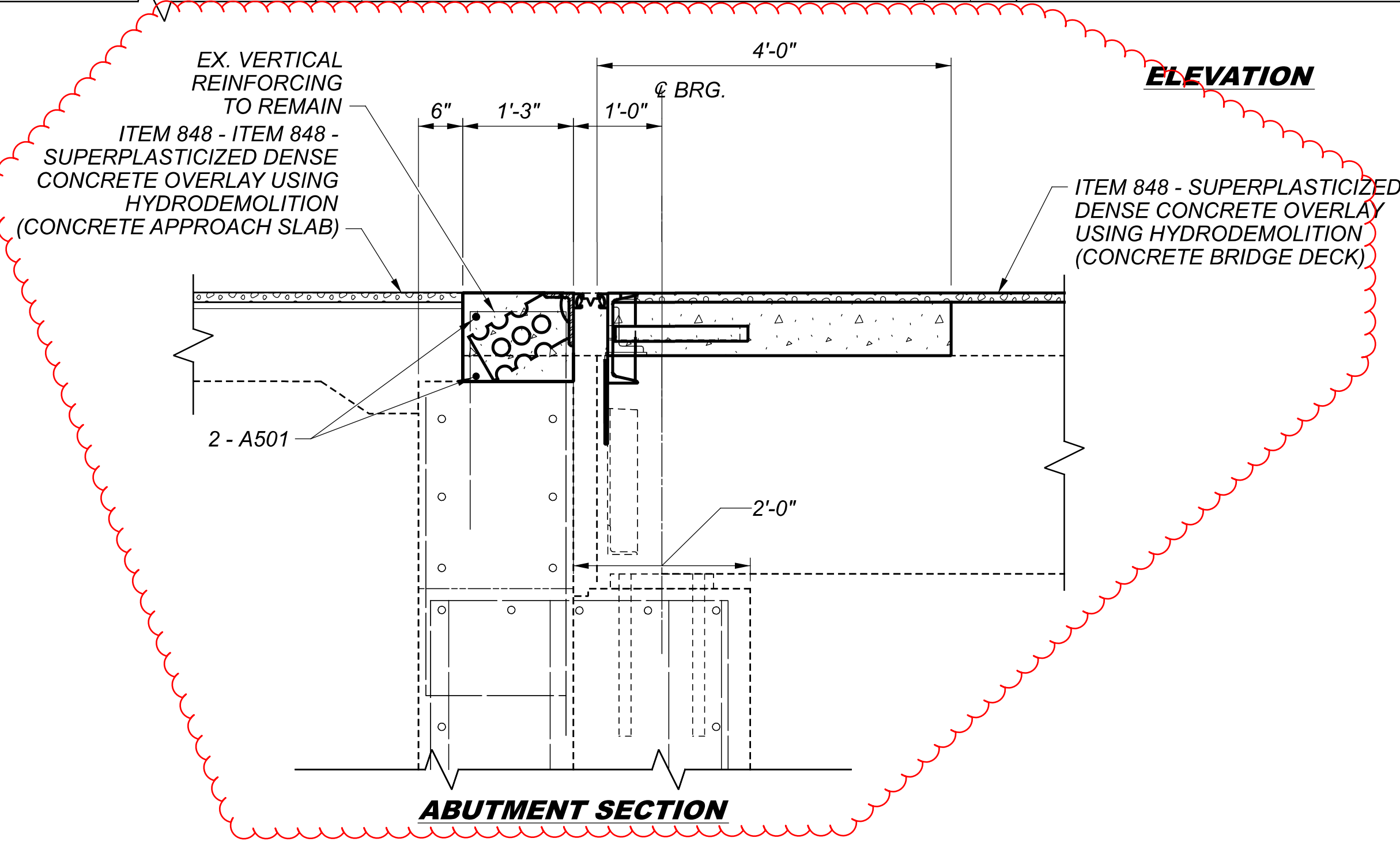

**ABUTMENT SECTION**

**LEGEND**

- ITEM 848 - SUPERPLASTICIZED DENSE CONCRETE OVERLAY USING HYDRODEMOLITION
- ITEM 511 - CLASS QC2 CONCRETE
- X SF CONCRETE PATCHING QUANTITY
- INDICATES AREA OF DETERIORATED CONCRETE TO BE PATCHED PER ITEM 519- PATCHING CONCRETE STRUCTURE, AS PER PLAN.

SFN	6801676
DESIGN AGENCY	
DESIGNER	GTF
CHECKER	AS
REVIEWER	CAH
DATE	03/28/23
PROJECT ID	100818
SUBSET	TOTAL
6	11
SHEET	TOTAL
28	53

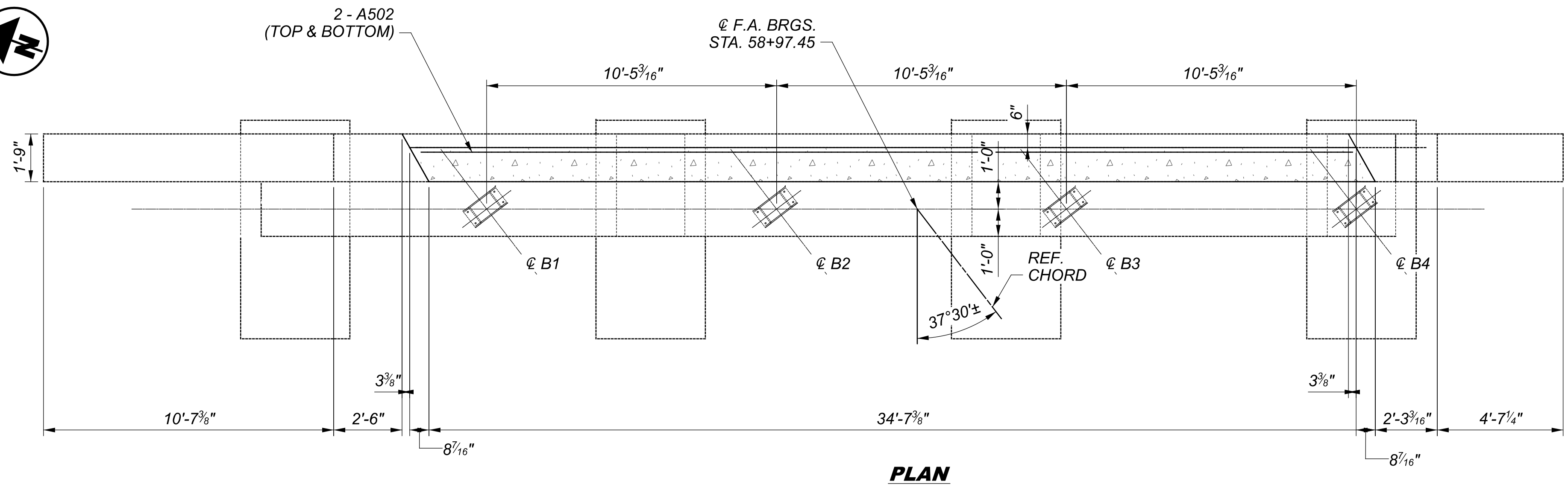

**PLAN**

**LEGEND**

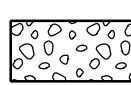
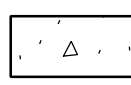
-  ITEM 848 - SUPERPLASTICIZED DENSE CONCRETE OVERLAY USING HYDRODEMOLITION
-  ITEM 511 - CLASS QC2 CONCRETE

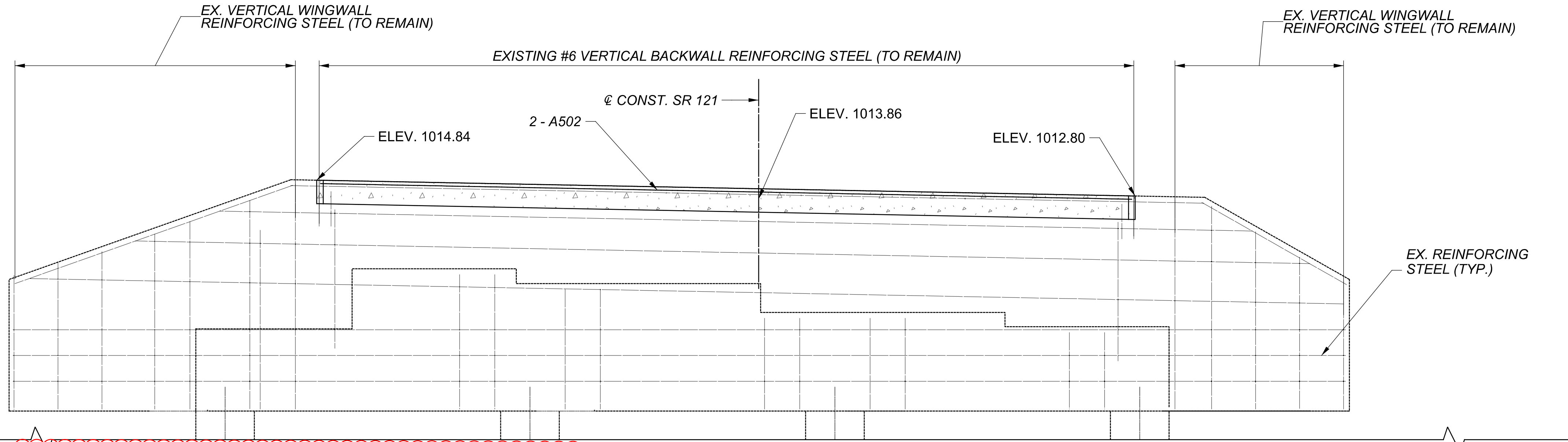

**ELEVATION**

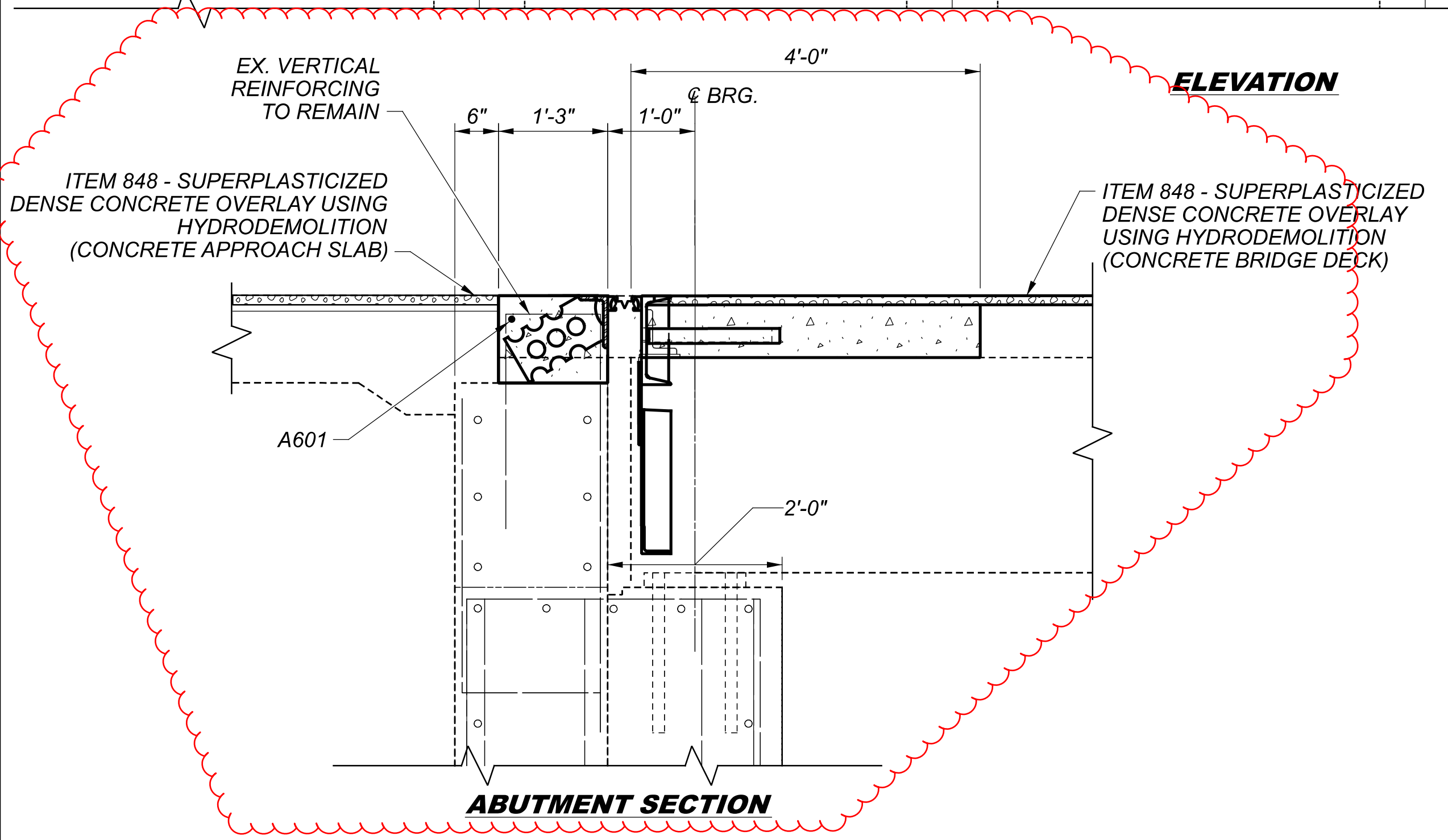

**ABUTMENT SECTION**

SFN	
6801676	
DESIGN AGENCY	
	
DESIGNER	CHECKER
GTF	AS
REVIEWER	
CAH 03/28/23	
PROJECT ID	
100818	
SUBSET	TOTAL
7	11
SHEET	TOTAL
29	53



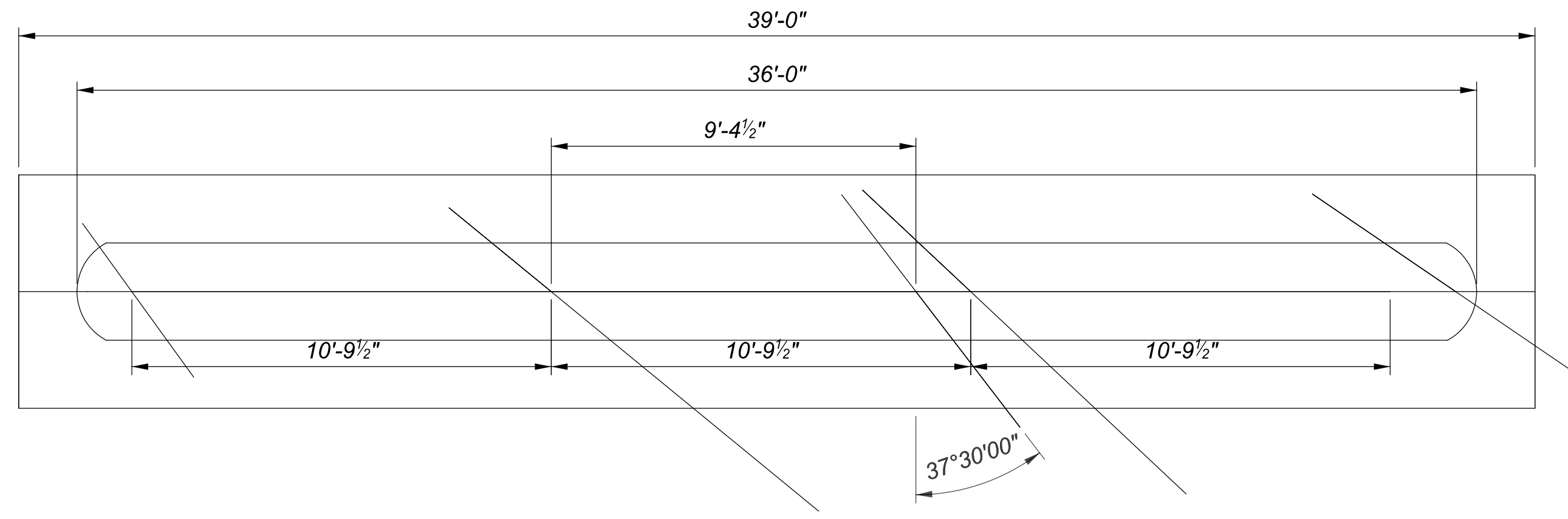

**PLAN VIEW**

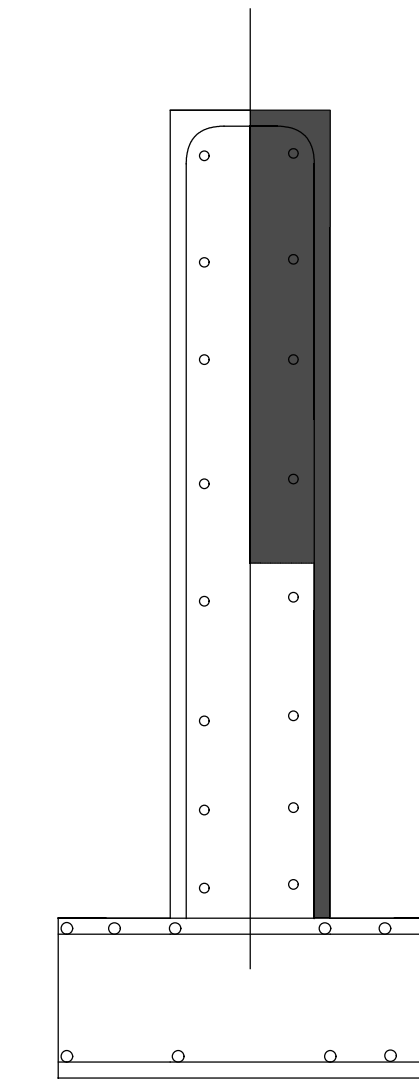

**SECTION VIEW**

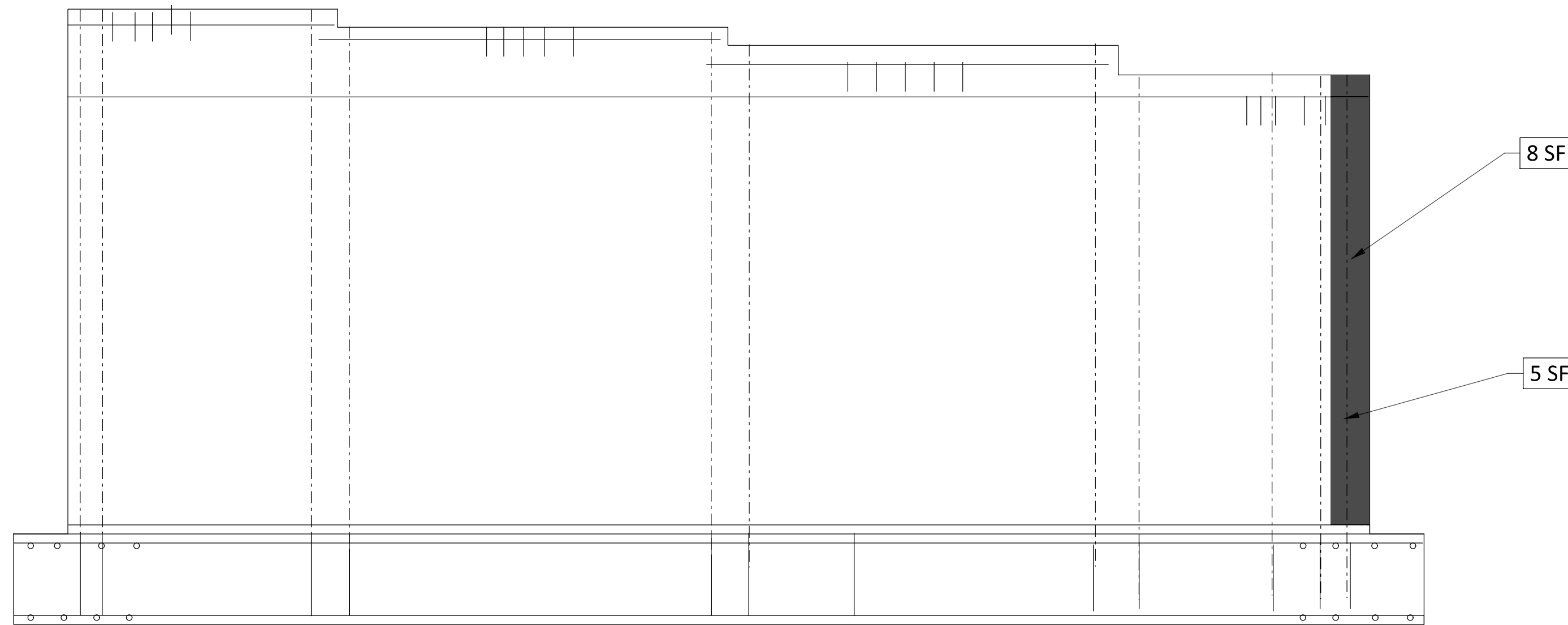

**ELEVATION VIEW**

**LEGEND**

- ITEM 519 - PATCHING CONCRETE STRUCTURES
- X SF CONCRETE PATCHING QUANTITY

DESIGNER	CHECKER
ARP	CAH
REVIEWER	
GTF 03/28/23	
PROJECT ID	
100818	
SUBSET	TOTAL
8	11
SHEET	TOTAL
30	53

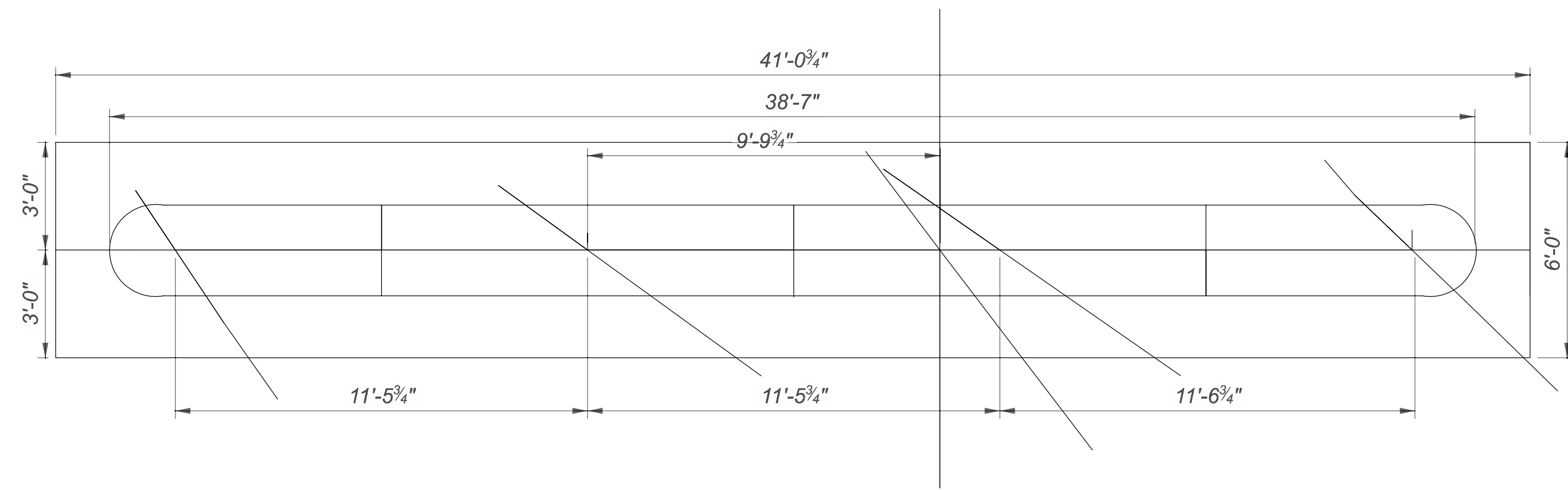

**PLAN VIEW**

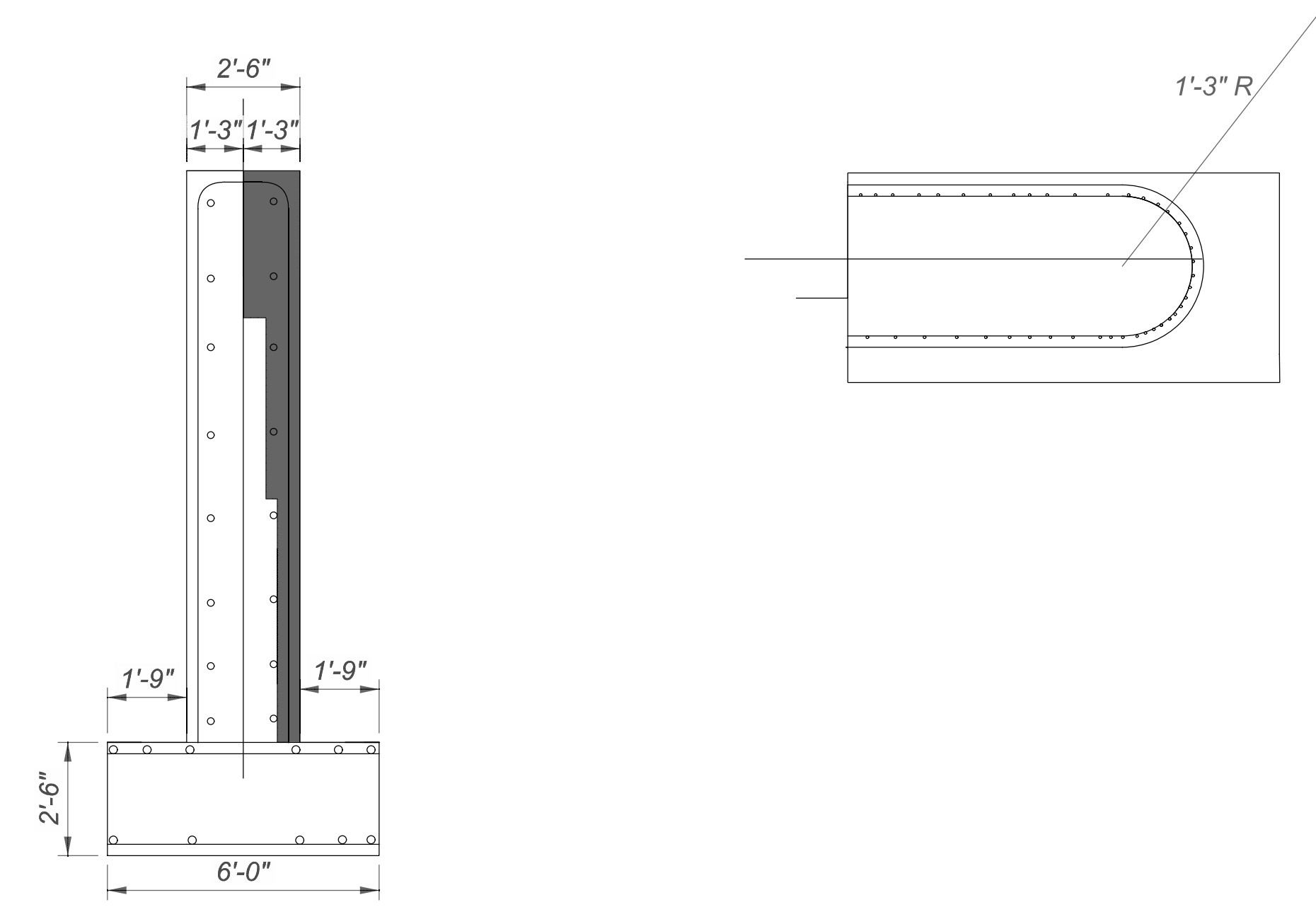

**SECTION VIEW**

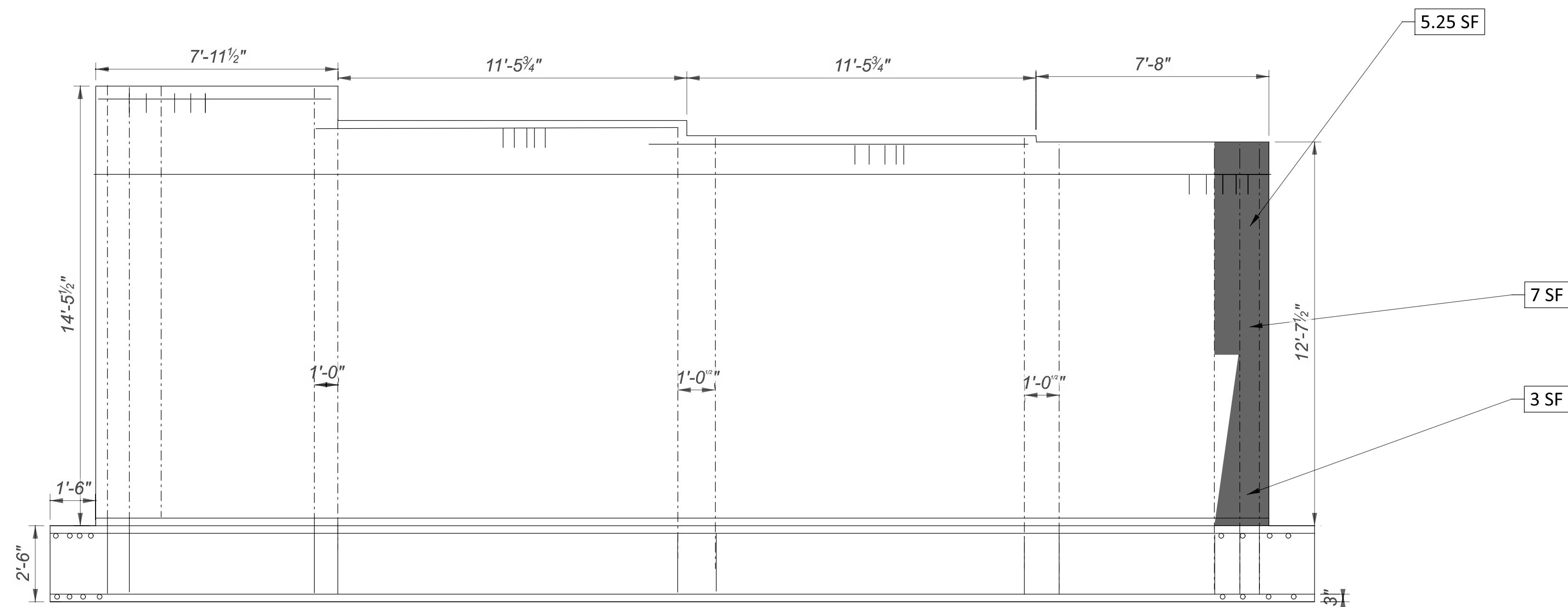

**ELEVATION VIEW**

**LEGEND**

- ITEM 519 - PATCHING CONCRETE STRUCTURES
- X SF CONCRETE PATCHING QUANTITY



ESTIMATED QUANTITIES - STRUCTURE No.: PRE-121-0207 (01/STR/13 FUNDING SPLIT)									
ITEM	EXTENSION	TOTAL	UNIT	DESCRIPTION	ABUT.	PIERS	SUPER.	GEN.	SEE SHEET
202	11203	LS	LS	PORTIONS OF STRUCTURE REMOVED, OVER 20 FOOT SPAN, AS PER PLAN	LUMP	LUMP	LUMP		36
202	22900	178	SY	APPROACH SLAB REMOVED				178	
202	23500	616	SY	WEARING COURSE REMOVED			438	178	
503	11100	LS	LS	COFFERDAMS AND EXCAVATION BRACING				LUMP	
503	21300	LS	LS	UNCLASSIFIED EXCAVATION					
509	26000	103874	LB	GALVANIZED STEEL REINFORCEMENT	4874	1681	97319		
510	10001	248	EACH	DOWEL HOLES WITH NON-SHRINK, NON-METALLIC GROUT, AS PER PLAN	248				36
511	33313	346	CY	CLASS QC2 CONCRETE WITH QC/QA, SUPERSTRUCTURE, AS PER PLAN	2	15	329		36
511	45712	4	CY	CLASS QC1 CONCRETE WITH QC/QA, ABUTMENT	4				
511	81200	LS	LS	CONCRETE MISC.: CONSULTANT FOR CONCRETE QUALITY CONTROL INCLUDING TESTING AND INSPECTION	LUMP	LUMP	LUMP		3
512	10100	163	SY	SEALING OF CONCRETE SURFACES (EPOXY-URETHANE)	90	15	58		
512	33000	2	SY	TYPE 2 WATERPROOFING	2				
514	00050	102	SF	SURFACE PREPARATION OF EXISTING STRUCTURAL STEEL		102			
514	00056	102	SF	FIELD PAINTING OF EXISTING STRUCTURAL STEEL, PRIME COAT		102			
516	13200	62	SF	½" PREFORMED EXPANSION JOINT FILLER	62				
516	13600	83	SF	1" PREFORMED EXPANSION JOINT FILLER	83				
516	14014	93	FT	INTEGRAL ABUTMENT EXPANSION JOINT SEAL	93				
517	70100	196	FT	RAILING (THREE STEEL TUBE BRIDGE RAILING)			196		
518	21200	47	CY	POROUS BACKFILL WITH GEOTEXTILE FABRIC	47				
SPECIAL	51822300	249	FT	STEEL DRIP STRIP			249		
518	40000	125	FT	6" PERFORATED CORRUGATED PLASTIC PIPE	125				
518	40010	25	FT	6" NON-PERFORATED CORRUGATED PLASTIC PIPE, INCLUDING SPECIALS	25				
526	15000	178	SY	REINFORCED CONCRETE APPROACH SLABS (T=13")				178	
526	90010	93	FT	TYPE A INSTALLATION				93	
846	00110	39	CF	POLYMER MODIFIED ASPHALT EXPANSION JOINT SYSTEM				39	

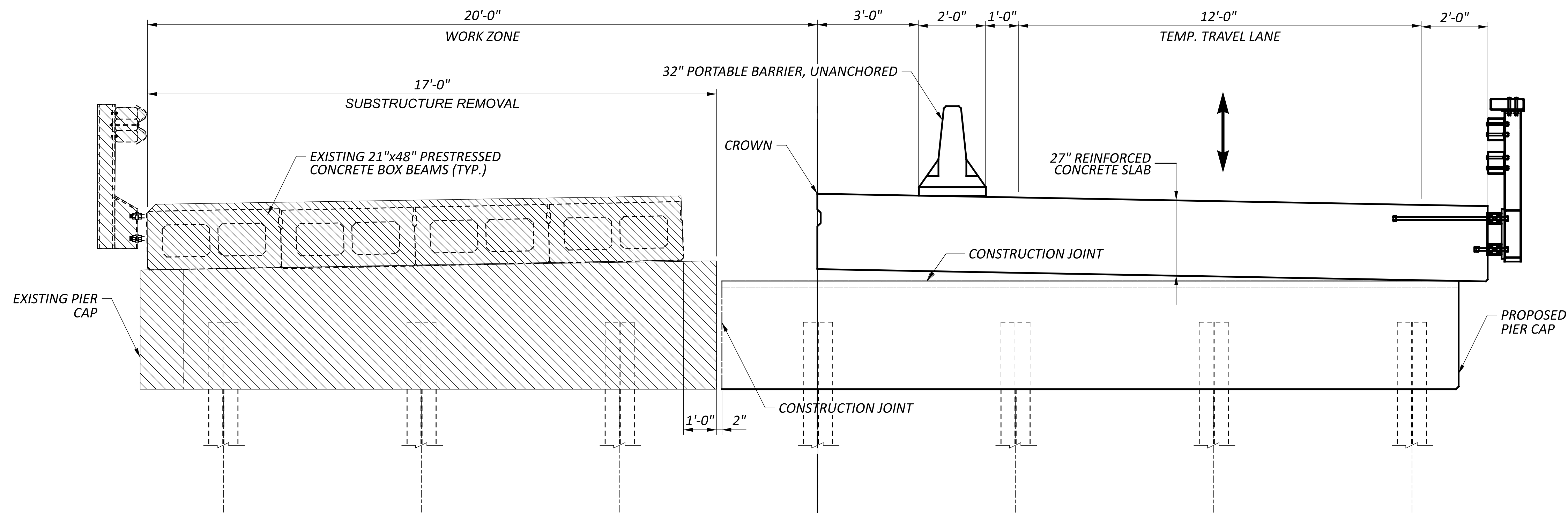

**PHASE 2 REMOVAL**

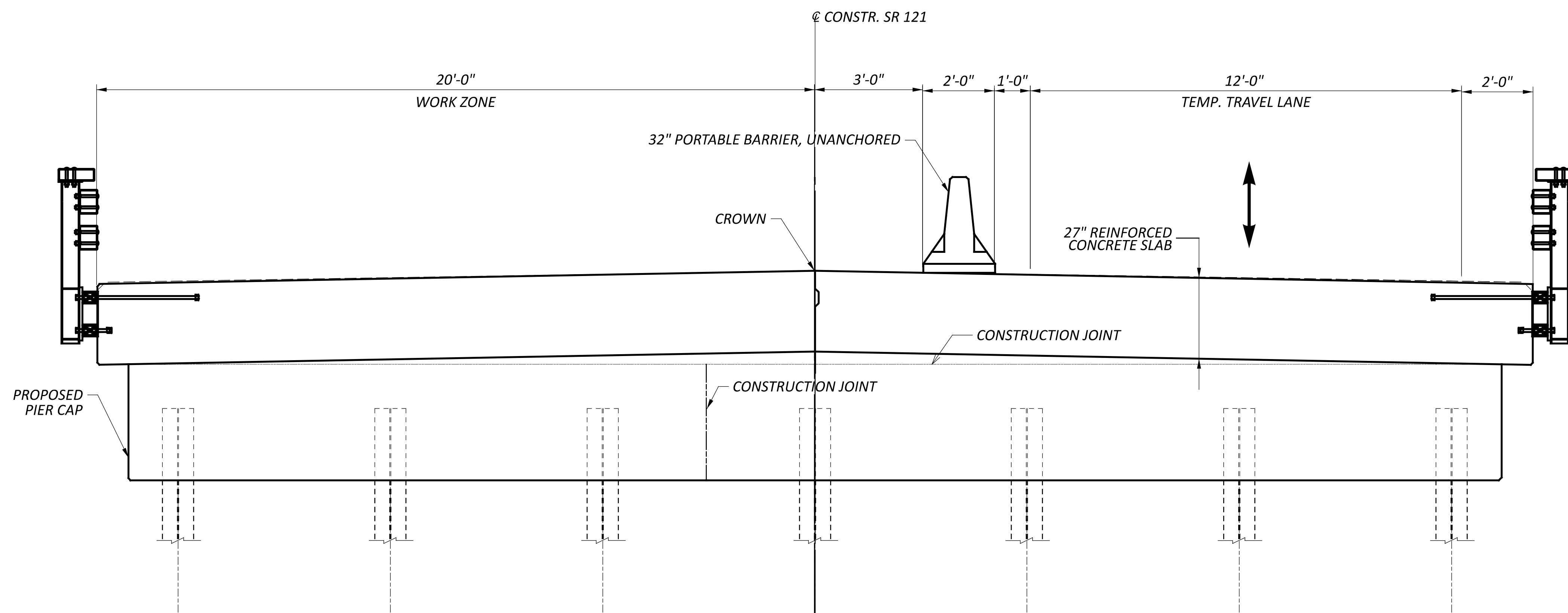

**PHASE 2 CONSTRUCTION**



DESIGNER	CHECKER
GTF	AS
REVIEWER	
CAH	03/28/23
PROJECT ID	100818
SUBSET	TOTAL
5	15
SHEET	TOTAL
39	53



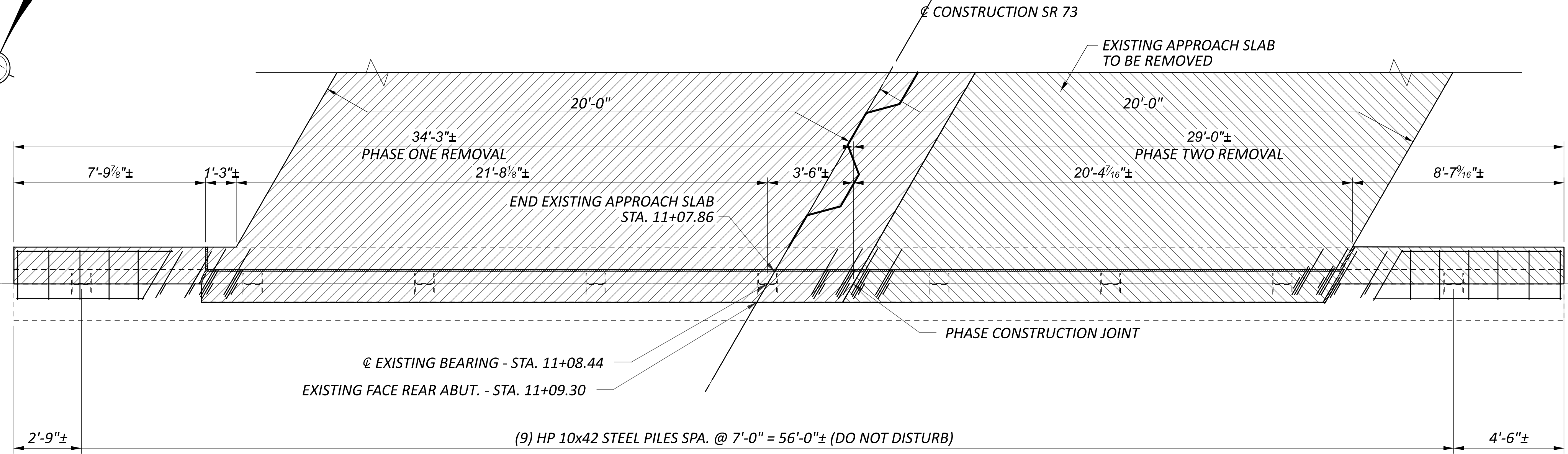
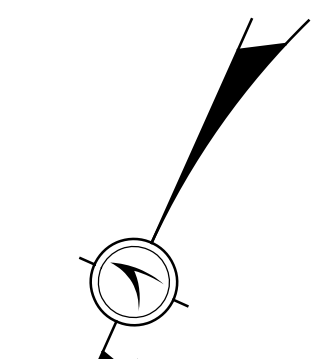

**REAR ABUTMENT PLAN**

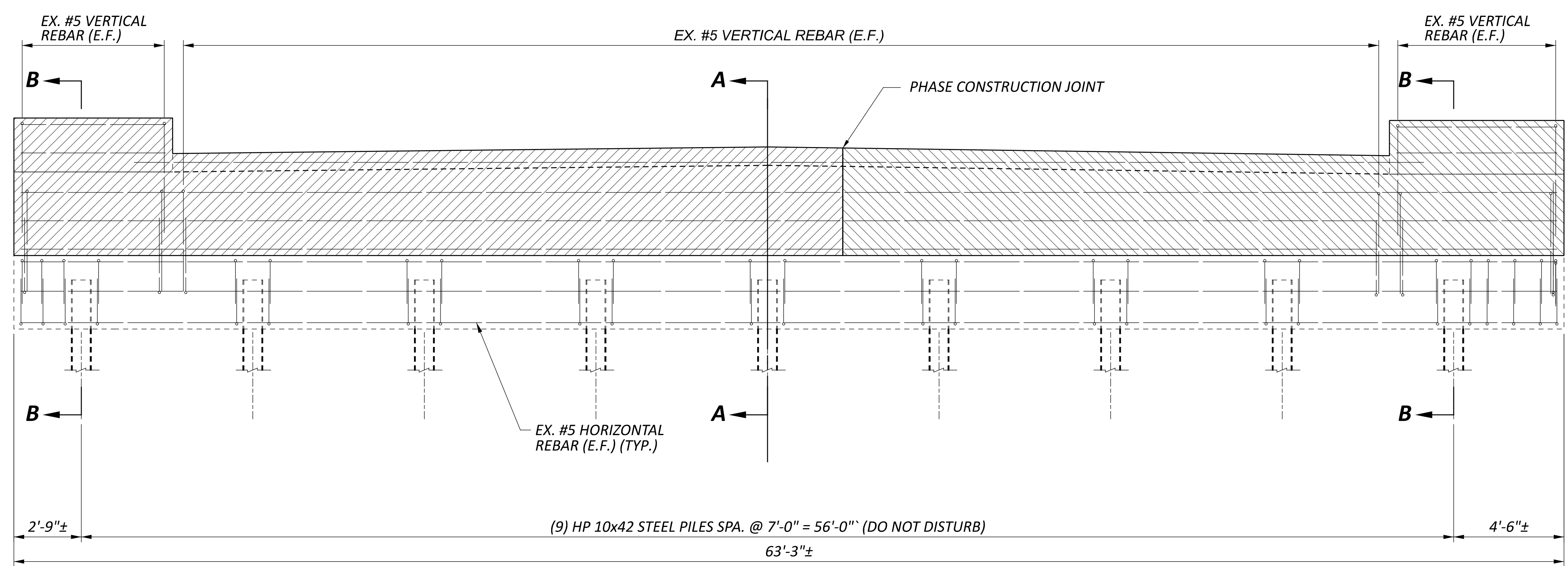

**REAR ABUTMENT ELEVATION**

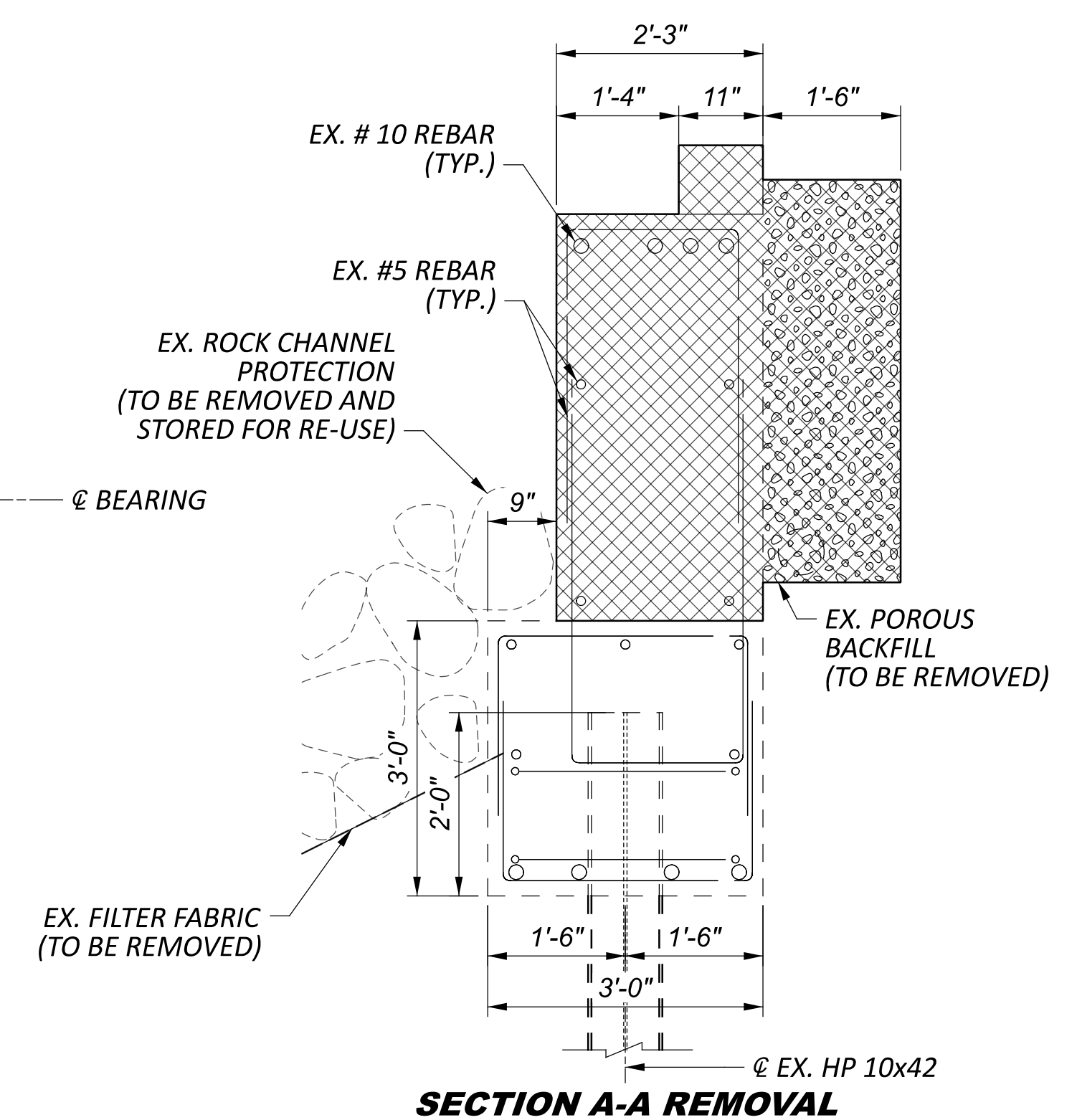

**SECTION A-A REMOVAL**

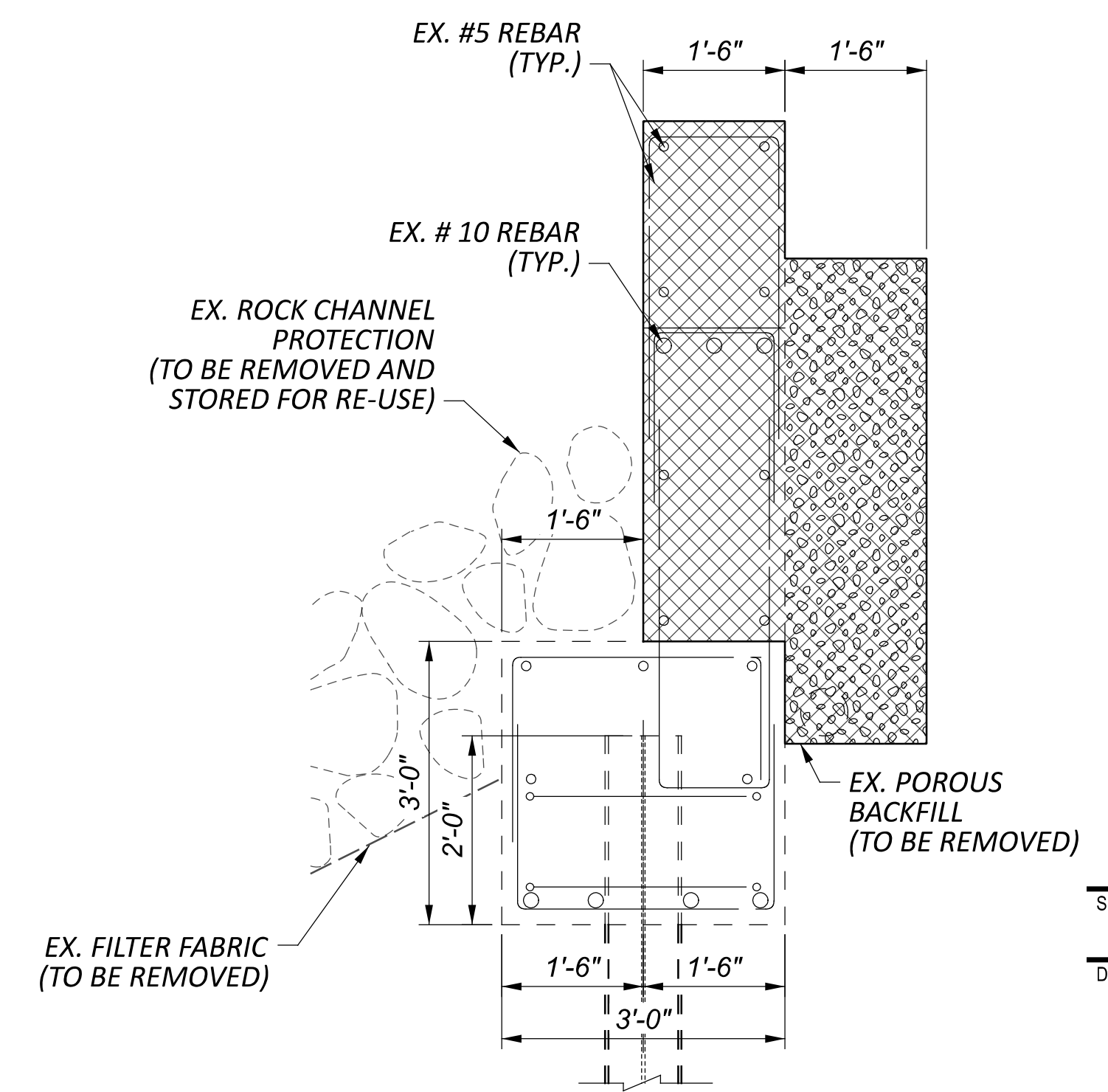

**SECTION B-B REMOVAL**

- LEGEND**
- PORTIONS OF STRUCTURE REMOVED (PHASE 1)
  - PORTIONS OF STRUCTURE REMOVED (PHASE 2)
  - PORTIONS OF STRUCTURE REMOVED (PHASE 1&2)
  - EXISTING POROUS BACKFILL (TO BE REMOVED)

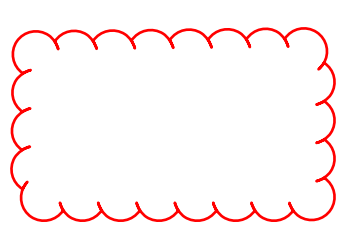

REAR ABUTMENT REMOVAL DETAILS  
 BRIDGE No.: PRE-121-0207  
 STATE ROUTE 121 OVER EAST FORK WHITEWATER RIVER

SFN  
 6802205  
 DESIGN AGENCY

DESIGNER	CHECKER
GTF	AS
REVIEWER	
PROJECT ID	100818
SUBSET	TOTAL
6	15
SHEET	TOTAL
40	53



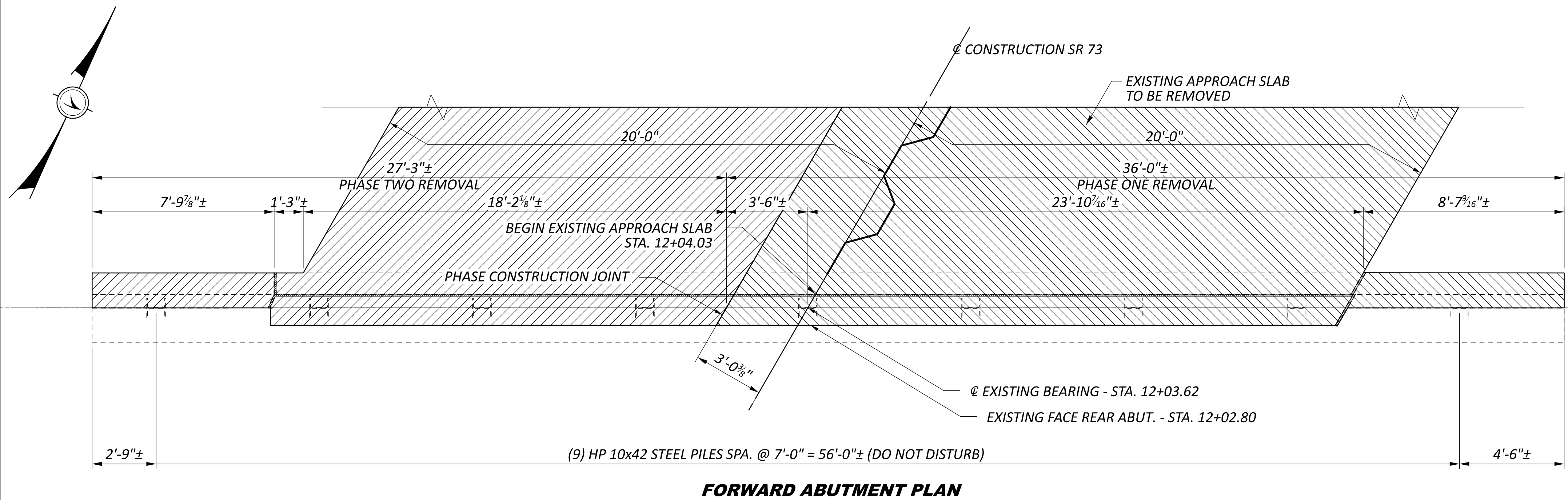

**FORWARD ABUTMENT PLAN**

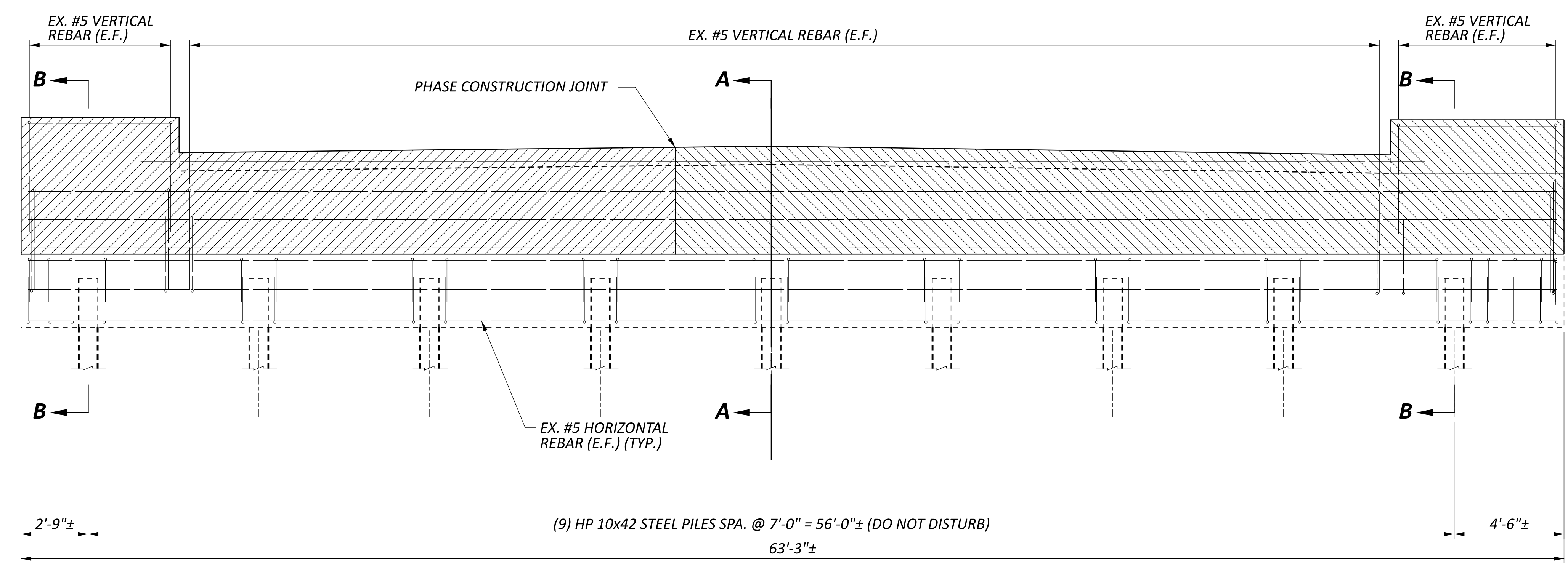

**FORWARD ABUTMENT ELEVATION**

- LEGEND**
- PORTIONS OF STRUCTURE REMOVED (PHASE 1)
  - PORTIONS OF STRUCTURE REMOVED (PHASE 2)
  - PORTIONS OF STRUCTURE REMOVED (PHASE 1&2)
  - EXISTING POROUS BACKFILL (TO BE REMOVED)

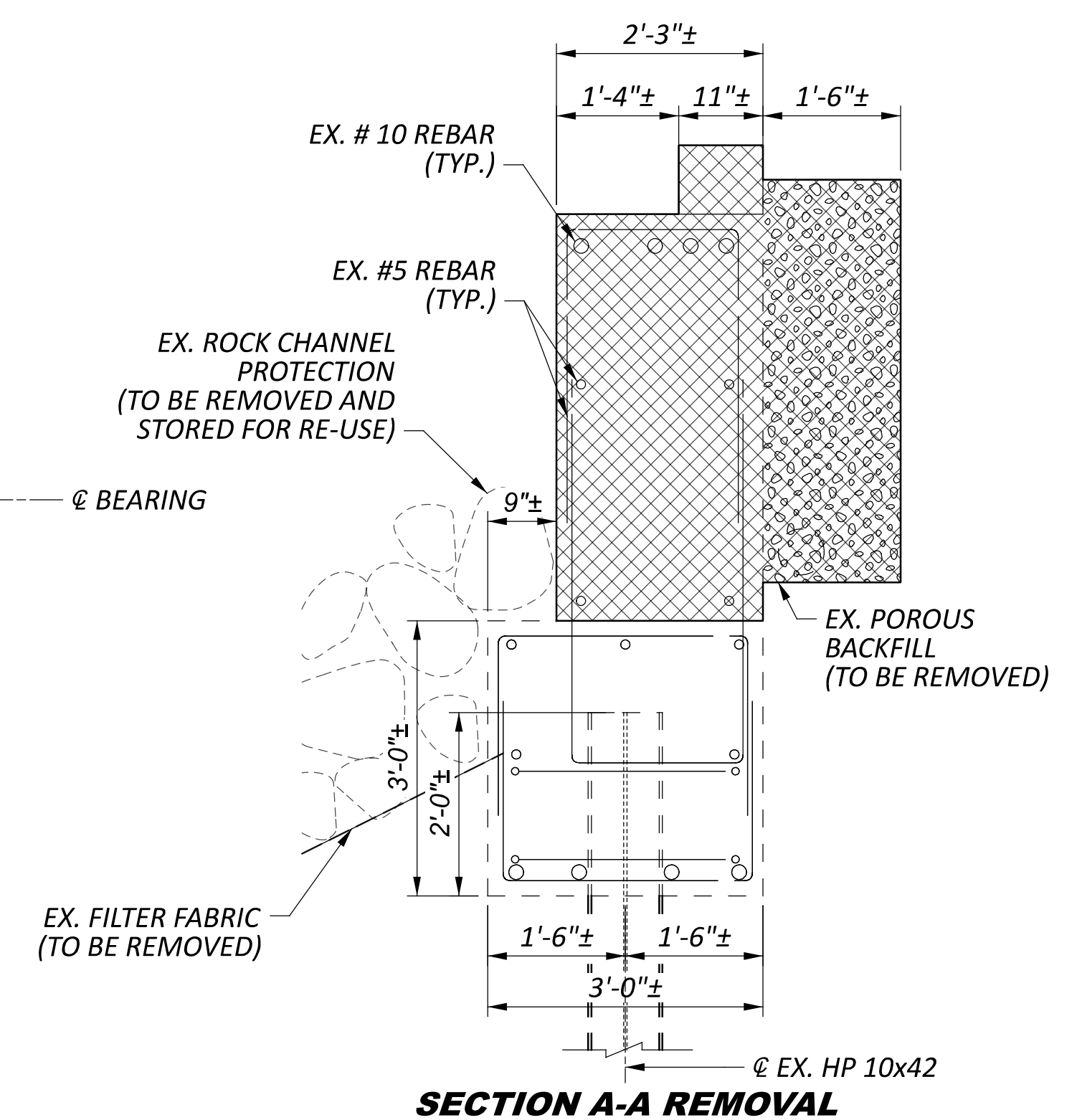

**SECTION A-A REMOVAL**

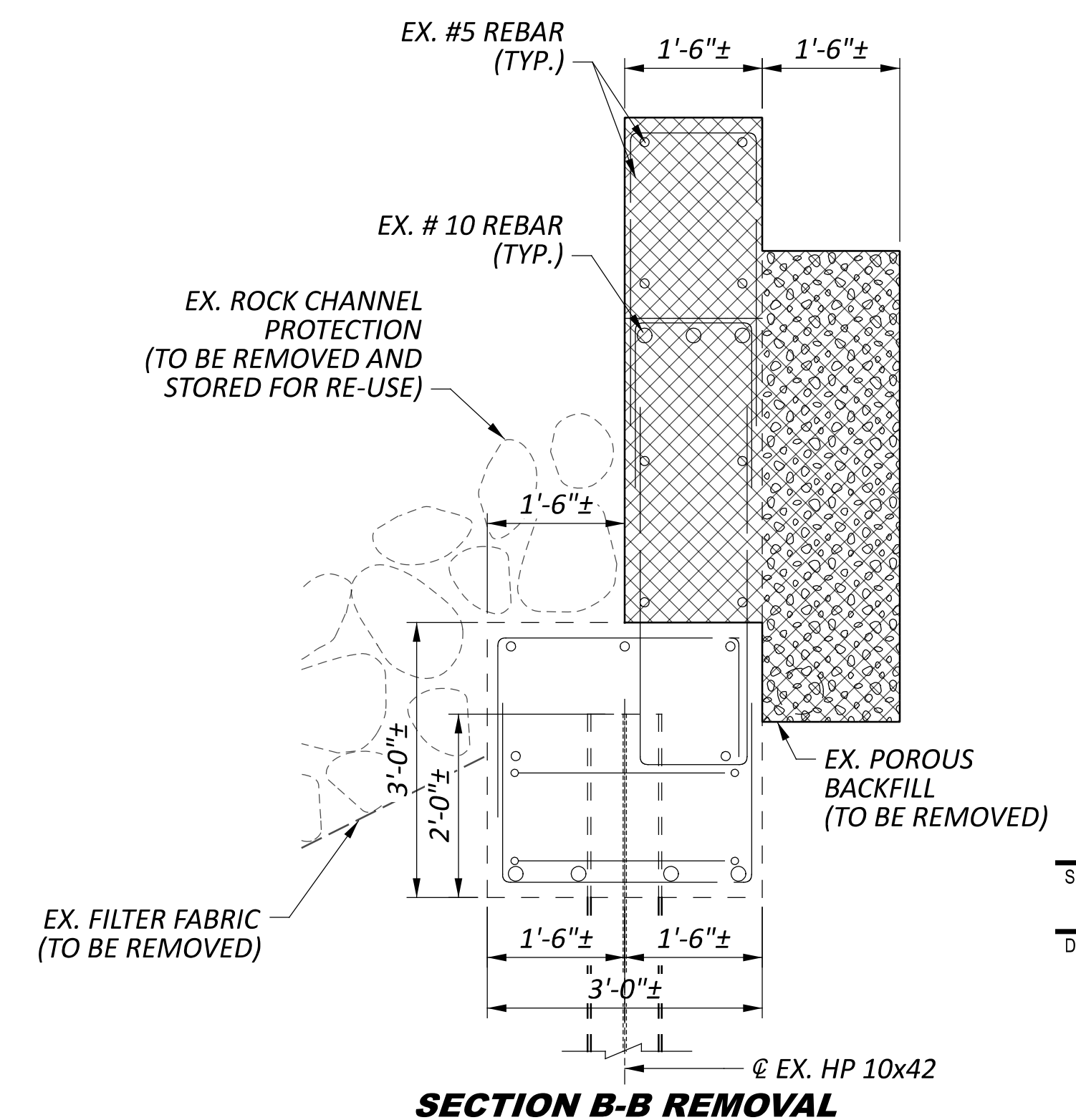

**SECTION B-B REMOVAL**

**FORWARD ABUTMENT REMOVAL DETAILS**  
**BRIDGE No.: PRE-121-0207**  
**STATE ROUTE 121 OVER EAST FORK WHITEWATER RIVER**

SFN  
 6802205  
 DESIGN AGENCY



DESIGNER CHECKER	
GTF	AS
REVIEWER	
CAH	03/28/23
PROJECT ID	
100818	
SUBSET	TOTAL
7	15
SHEET	
41	53



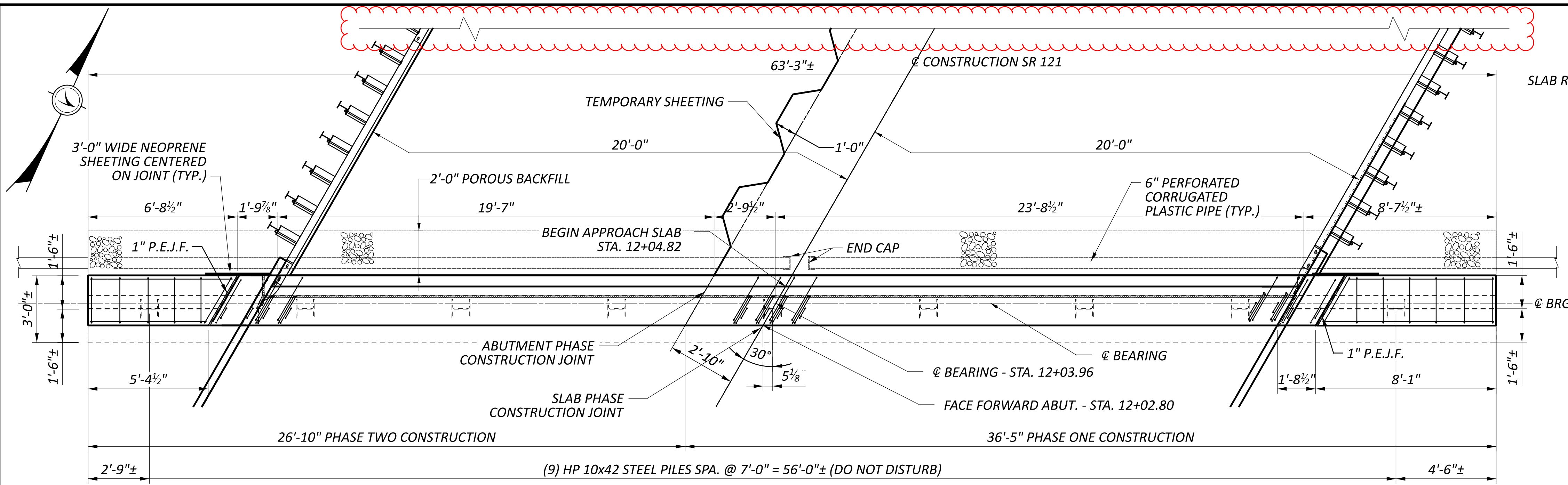

**FORWARD ABUTMENT PLAN**

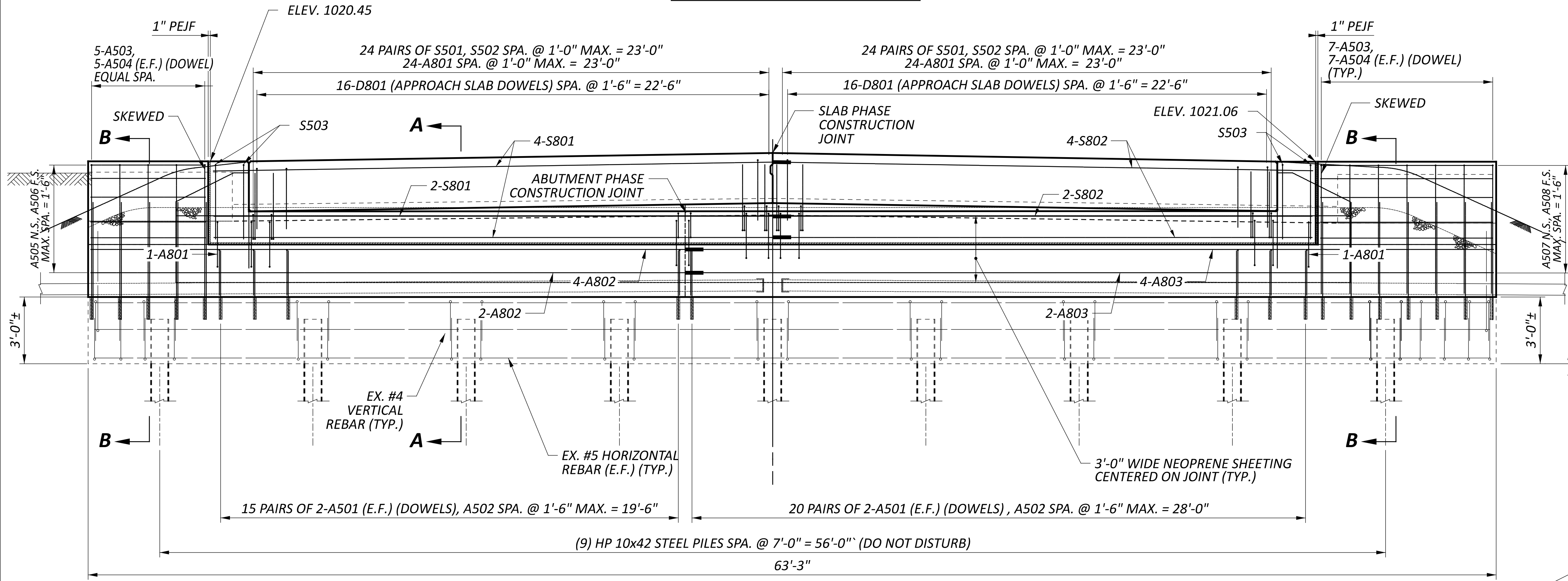

**FORWARD ABUTMENT ELEVATION**

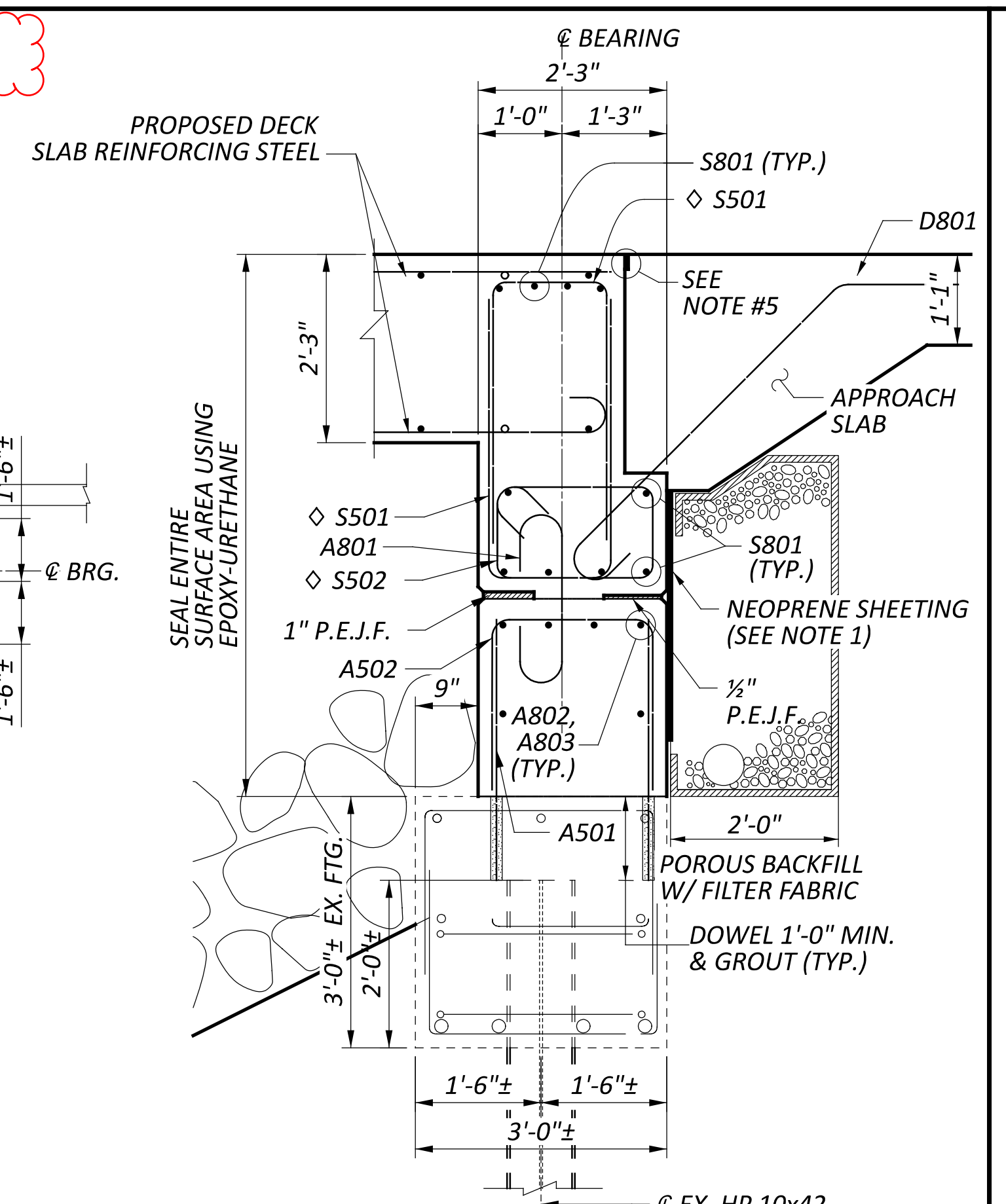

**SECTION A-A CONSTRUCTION**

PLACE S501 & S502 BARS PARALLEL WITH THE DECK SLAB LONGITUDINAL BARS.

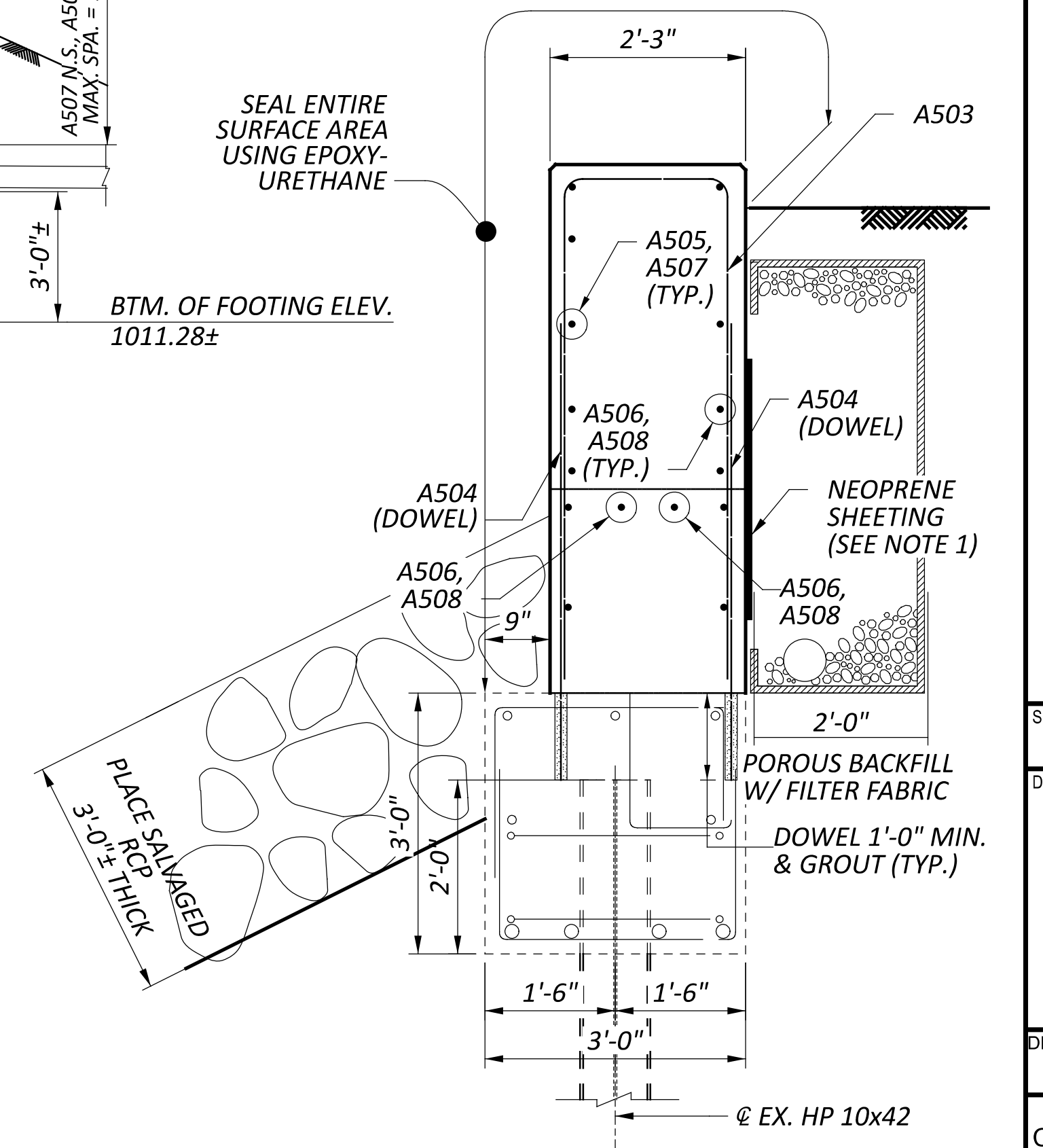

**SECTION B-B CONSTRUCTION**

**LEGEND**

N.S.	- NEAR SIDE
F.S.	- FAR SIDE
E.F.	- EACH FACE
P.E.J.F.	- PREFORMED EXPANSION JOINT FILLER
	- PROPOSED GROUND LINE

- NOTES:**
- 3'-0" WIDE NEOPRENE SHEETING CENTERED ALONG TOP OF EXISTING FOOTING OR TYPE 2 WATERPROOFING PLACED AS SHOWN IN THE PLANS.
  - SEAL EXPOSED SURFACES OF ABUTMENT, WINGWALLS WITH EPOXY URETHANE SEALER, FEDERAL COLOR 17778.
  - SEE STD-DWG CPA-1-08, FOR DETAILS NOT SHOWN.
  - DRILL DOWEL HOLES, 12" MINIMUM REBAR EMBEDMENT USING NON-SHRINK, NON-METALLIC GROUT, AS PER CMS 510.03.
  - APPLY TYPE 2 WATERPROOFING TO ALL CONSTRUCTION JOINTS BEYOND LIMITS OF NEOPRENE SHEETING
  - PREFORMED ELASTOMERIC COMPRESSION JOINT SEAL, 705.11 (1 1/4" WIDE FOR A 1/2" WIDE GROOVE) PLACED IN 1/2" x 2 1/4" GROOVE.

SFN	6802205
DESIGN AGENCY	
DESIGNER	GTF
CHECKER	AS
REVIEWER	CAH
DATE	03/28/23
PROJECT ID	100818
SUBSET	9
TOTAL	15
SHEET	43
TOTAL	53